



Allen-Bradley

***1394 Digital AC
Multi-Axis
Motion Control
System***

(Catalog No. 1394-50)

User Manual

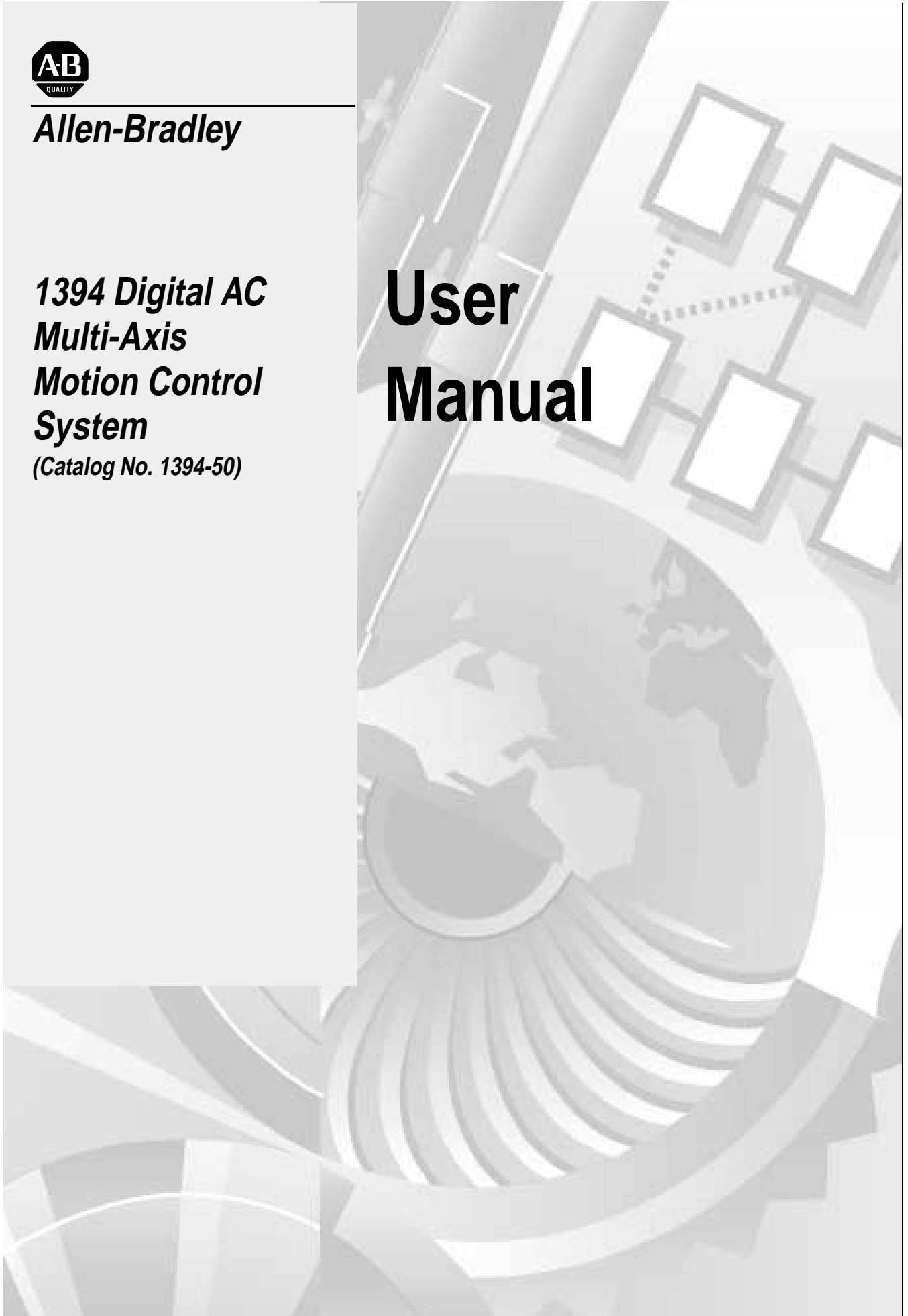

Important User Information

Because of the variety of uses for the products described in this publication, those responsible for the application and use of this control equipment must satisfy themselves that all necessary steps have been taken to assure that each application and use meets all performance and safety requirements, including any applicable laws, regulations, codes and standards.

The illustrations, charts, sample programs and layout examples shown in this guide are intended solely for purposes of example. Since there are many variables and requirements associated with any particular installation, Allen-Bradley does not assume responsibility or liability (to include intellectual property liability) for actual use based upon the examples shown in this publication.

Allen-Bradley publication SGI-1.1, *Safety Guidelines for the Application, Installation, and Maintenance of Solid-State Control* (available from your local Allen-Bradley office), describes some important differences between solid-state equipment and electromechanical devices that should be taken into consideration when applying products such as those described in this publication.

Reproduction of the contents of this copyrighted publication, in whole or in part, without written permission of Allen-Bradley Company, Inc., is prohibited.

Throughout this manual we use notes to make you aware of safety considerations:



ATTENTION: Identifies information about practices or circumstances that can lead to personal injury or death, property damage or economic loss.

Attention statements help you to:

- identify a hazard
- avoid the hazard
- recognize the consequences

Important: Identifies information that is critical for successful application and understanding of the product.

Table of Contents

Preface	Who Should Use this Manual	P-1
	Purpose of this Manual	P-1
	Contents of this Manual	P-2
	Related Documentation	P-3
	Conventions Used in this Manual	P-3
	Module Series Designator	P-3
	1394 Product Receiving and Storage Responsibility	P-4
	Allen-Bradley Support	P-4
	Local Product Support	P-4
	Technical Product Assistance	P-4
	Chapter 1	
Overview	The 1394 System	1-1
	Series Note	1-1
	Safety Precautions	1-2
	1394 System Overview	1-3
	GMC System	1-3
	CNC Interface System	1-5
	SERCOS System	1-6
	Analog Servo System	1-7
	9/440 CNC System	1-8
	What is a 1394 System?	1-9
	System Modules	1-10
	Axis Modules	1-11
	External Shunt Module (used with 22 kW System)	1-11
	1326AB Motors	1-12
	1326AS Motors	1-12
	1326AH Motors	1-13
	Drive Interface Module	1-14
	DC Link Module	1-14
	Standard Features of the 1394	1-15
	Control	1-15
	Power	1-16
	Integration	1-16
	Chapter 2	
Installing Your 1394 (applies to all systems)	Chapter Objectives	2-1
	Complying With European Union Directives	2-1
	EMC Directive	2-1
	Low Voltage Directive	2-2
	Before Mounting Your System	2-2
	Storing Your 1394 Before Installation	2-2
	Unpacking Modules	2-3
	System Mounting Requirements	2-3
	Determining Your System Mounting Hole Layout	2-4
	Mounting Your 1394 Through the Back of the Cabinet	2-6
	Bonding Your System	2-6
	Bonding Modules	2-6
	Bonding Multiple Subpanels	2-8

Mounting Your 1394 System	2-8
Mounting Your 1394-DCLM	2-11
Mounting the External Shunt Resistor for 5 and 10 kW System Modules	2-11
Mounting External Shunt Modules for 22 kW System Modules	2-11
Shunt Module Mounting Orientation	2-12
Shunt Module Mounted Outside the Cabinet	2-13
Shunt Module Mounted Inside the Cabinet	2-14
Mounting the Shunt Module	2-15
Mounting Considerations for GMC and GMC Turbo Systems	2-16
Mounting GMC and GMC Turbo Systems Next to Flex I/O	2-16

Chapter 3

Wiring System, Axis, and Shunt Modules, and Motors (for all systems)

Chapter Objectives	3-1
Finding Additional Wiring Information for 1394 Systems	3-1
Understanding Basic Wiring Requirements	3-2
Routing High and Low Voltage Cables	3-3
System Module Wire Sizes	3-4
Shielding	3-4
EMI/RFI Shielding	3-4
EMI/RFI Bonding	3-4
Input Power Conditioning	3-5
Determining Your Type of Input Power	3-6
Grounded Power Configuration	3-6
Ungrounded Power Configuration	3-7
Setting the Ground Jumper in a 5 or 10 kW System Module for Ungrounded Power Configurations	3-8
Setting the Ground Jumper in a 22 kW System Module for Ungrounded Power Configurations	3-9
Grounding Your 1394 System	3-12
Grounding your System to the Subpanel	3-12
Grounding Multiple Subpanels	3-13
Wiring System Module Power	3-13
Terminal Block Locations for 5 and 10 kW System Module (Series A and B)	3-14
Connector Locations for 5 and 10 kW System Module (Series C) ...	3-15
Terminal Block Locations for a 22 kW System Module	3-16
Required Tools and Equipment	3-17
Connecting Power Wiring for 5 and 10 kW (Series A and B) and 22 kW System Modules	3-17
Connecting Power Wiring for 5 and 10 kW System Modules (Series C)	3-18
Connecting Motor Power to Axis Modules	3-19
Connecting Thermal and Brake Leads to Axis Modules	3-20
Required Tools and Equipment	3-20
Wiring Motor Power, Thermals and Brakes	3-21
Connecting Feedback to System Modules	3-24
Connecting Your Motor Cables to Motors	3-26
Connecting Your External Shunt Resistor	3-26
Connecting Your External Shunt Resistor (Series A and B)	3-27
Connecting Your External Shunt Resistor (Series C)	3-28

	Connecting Your Shunt Module (required for 22 kW system)	3-28
	Required Tools and Equipment	3-28
	Wiring the Shunt Module Power	3-29
	Wiring Shunt Module Fan Power	3-33
	 Chapter 4	
Wiring 1394 GMC and GMC Turbo Systems	Chapter Objectives	4-1
	Finding Additional Wiring Information for 1394 Systems	4-1
	Understanding GMC and GMC Turbo Wiring and Connections	4-1
	Understanding Input Wiring Board Layout	4-2
	Using the Terminal Operating Tool to Insert Wires	4-4
	Input Wiring Board Signal Descriptions	4-5
	Connecting Your Communication Cables	4-7
	Encoder Feedback Wiring	4-10
	Serial Communications	4-11
	Data Highway Connection	4-13
	AxisLink	4-14
	GMC Turbo System	4-15
	Remote I/O	4-16
	Flex I/O	4-16
	SLC Interface	4-17
	Connecting a GMC and GMC Turbo to a 1394-DIM	4-19
	1394-DIM System Example	4-19
	1394-DIM with 1398-DDM-xxx System Example	4-20
	1394-DIM Configurations	4-21
	Configuration Examples	4-22
	1394-System Module Input Power Wiring When Not Using Axis Modules	4-24
	Understanding DIM Signals	4-24
	DROK	4-24
	Drive Enable Output	4-25
	Analog Output	4-25
	Wiring and Configuring an External Drive to the 1394-DIM	4-26
	Connecting the Remote Drive to the DIM Connector	4-26
	Connecting the Position Feedback Encoder to the Feedback Input	4-29
	Connecting the DIM Ground Wire to the 1394 System Ground	4-30
	Installing the Resolver Feedback Input Plug	4-30
	 Chapter 5	
Wiring Your 1394 Analog Servo System	Chapter Objectives	5-1
	Finding Additional Wiring Information for 1394 Systems	5-1
	Understanding Analog Servo Wiring and Connections	5-1
	Input Wiring Board Layout	5-2
	Using the Terminal Operating Tool to Insert Wires	5-2
	Input Wiring Board Signal Descriptions	5-4
	Connecting AQB and SCANport Cables	5-5
	Analog Servo Encoder (A Quad B) Wiring	5-5
	SCANport Adapter	5-7

Commissioning 1394 GMC and GMC Turbo Systems

Chapter 6

Chapter Objectives	6-1
General Startup Precautions	6-1
Applying Power to the System	6-2
Setting Up Your System Using GML Commander	6-3
Before You Begin	6-3
Preparing the System	6-4
Setting Up Your System Using GML 3.x.x	6-5
Before You Begin	6-5
Preparing the System	6-5

Commissioning Your 1394 Analog Servo System

Chapter 7

Chapter Objectives	7-1
General Startup Precautions	7-1
Setting Up Your 1394 Analog Servo System	7-2
Before You Begin	7-2
Exiting Before You're Finished	7-2
Continuing From Where You Left Off	7-2
Removing and Re-Applying Power	7-3
Setting Up at the System Level	7-4
Setting Up Analog Test Points	7-5
Defining Your Motor	7-5
Defining a Reference Source for Your Axes	7-6
Defining Analog Velocity	7-7
Defining Analog Torque	7-8
Defining Digital Velocity	7-8
Defining Digital Torque	7-9
Defining Limits	7-10
Auto Tuning	7-11
Before You Perform an Auto Tune	7-11
Performing the Auto Tune	7-11

Configuring Your 1394 Analog Servo System

Chapter 8

Chapter Objectives	8-1
Where to Look for Other Programming Information	8-1
Conventions Used in this Chapter	8-2
Understanding Analog Servo System Parameters	8-3
1394 Analog Servo Software Diagrams	8-28

Troubleshooting

Chapter 9

Chapter Objectives	9-1
Understanding How to Detect a Problem	9-2
Understanding System and Axis Module LEDs	9-2
Understanding System Faults	9-5
Finding GMC Faults	9-5
Viewing Instantaneous Status	9-5
Viewing Continuous Status	9-6
Finding Analog Servo System Faults	9-7

Finding 9/440 Faults	9-7
Finding CNC Interface Faults	9-8
Understanding GMC Turbo and GMC Controller Faults.	9-9
Understanding Analog Servo System Module Faults	9-10
Understanding Analog Servo System Axis Faults	9-12
Troubleshooting General System Problems.	9-13
Replacing System and Axis Modules	9-16
Before You Begin	9-16
Removing an Axis Module	9-17
Installing a Replacement Axis Module	9-18
Removing a System Module	9-19
Installing a Replacement System Module	9-20
Replacing System Modules of the Same Series	9-22
Replacing System Modules of a Different Series	9-22
Completing Connections and Downloading Parameters	9-22
Checking for a Blown Fuse in the 1394-DCLM	9-23
Replacing the 1394 Shunt Module Fuse	9-25
Replacing the 1394-SR10A Fuse	9-25
Replacing the 1394-SR9A, -SR9AF, -SR36A, and -SR36AF Fuse	9-26
Replacing the AM50 and AM75 Axis Module Fan	9-28
Removing the Fan	9-28
Installing the New Fan	9-31

Appendix A

Specifications

Chapter Objectives	A-1
System Specifications	A-1
Certification	A-1
System Modules	A-2
Axis Modules	A-3
Contact Ratings	A-3
DC Link Module	A-4
Drive Interface Module	A-4
Filters	A-4
User-Supplied Contactor (M1)	A-5
User-Supplied Line Input Fusing	A-5
User-Supplied 24V Logic Input Power	A-5
Input Transformer for 24V Control Power	A-6
User-Supplied 5V Auxiliary Encoder Power Supply	A-6
Circuit Breakers	A-6
External Shunt Resistor Kit for 5 and 10 kW Systems	A-8
1394 Shunt Module for the 22 kW System	A-8
Environmental Specifications.	A-9
Power Dissipation	A-10
System Modules	A-10
Axis Modules	A-10
DC Link Module	A-11
Drive Interface Module	A-11
Internal Shunt Resistor for the 5 and 10 kW System (standard)	A-11
Communication Specifications.	A-11
Encoder Input Specifications	A-11

Dedicated Discrete I/O Specifications	A-12
Serial I/O Specifications	A-12
DH-485 Specifications	A-13
Flex I/O Specifications	A-13
GMC System Specifications	A-14
Remote I/O Adapter Specifications	A-15
AxisLink Specifications	A-16
Dimensions	A-17
1394 System Module Dimensions	A-17
Axis Module Dimensions	A-18
Filter Dimensions	A-20
External Shunt Dimensions	A-22
Motor Dimensions	A-25
Servo Motor Performance Data	A-32
1326AB Performance Data	A-32
1326AS Performance Data	A-33

Interconnect and CE Diagrams

Appendix B

Chapter Objectives	B-1
GMC, Analog Servo, and CNC Interface Interconnect Diagrams	B-2
1394 GMC Interconnections	B-3
1394 Analog Servo Interconnections	B-9
1394 CNC Interconnections	B-12
Thermal Interconnect Diagrams	B-14
1394 GMC Systems (1394x-SJTxx-C and -T)	B-15
1394 GMC Systems (1394C-SJTxx-L)	B-19
1394 Analog Servo Systems (1394x-SJTxx-A)	B-21
Cable Pin-outs	B-23
1326 Cable Pin-outs	B-23
1394 Cable Pin-outs	B-26
Grounding for 1394 CE Requirements	B-30

Using the Human Interface Module (HIM)

Appendix C

Chapter Objectives	C-1
The Human Interface Module (HIM)	C-1
Understanding HIM Keys	C-2
Understanding HIM Operation	C-4
Understanding HIM Modes	C-5
Display Mode	C-5
Program Mode	C-5
Link Mode	C-5
Startup Mode	C-5
EEPROM Mode	C-5
Search Mode	C-6
Control Status Mode	C-6
Password	C-6
Linking Parameters	C-6
Using Copy Cat	C-7
Copying a System's Information	C-8

Pasting a System's Information	C-9
Auto Tuning	C-10
Getting an Overview of HIM Programming	C-11
Removing the HIM	C-14
Removing the HIM from the HIM Cradle	C-14
Disconnecting the HIM from the System Module	C-14
Setting Up the HIM for Hand-Held Use	C-15
Placing the HIM in the HIM Cradle	C-16

Catalog Numbers

Appendix D

Understanding Catalog Numbers	D-1
Determining Catalog Numbers	D-1
System Modules	D-2
1394 System Module	D-2
9/440 System Module (Resolver based systems)	D-2
CNC Serial Drive System Module	D-3
9/440 High Resolution/Absolute CNC System Module	D-3
Axis Modules	D-4
External Shunt Modules	D-4
Shunt Resistor Kit for 5 and 10 kW System Modules	D-4
Shunt Modules for 22 kW System Modules	D-4
System Module Cables	D-5
Control Interface Cables	D-5
Single Axis Flying Lead Cable	D-5
Two-Axis Prewired Cable	D-5
1326AB Servo Motors	D-6
1326 Shaft Oil Seal Kit for 1326AB Motors	D-6
Motor Junction Box Kit for 1326AB Motors	D-7
Feedback Mounting Adapter Kit for 1326AB Motors	D-7
1326AS Servo Motors	D-8
1326 Shaft Oil Seal Kit for 1326AS Motors	D-8
Motor Junction Box Kit for 1326AS Motors	D-9
Feedback Mounting Adapter Kit for 1326AS Motors	D-9
1326AH Servo Motors	D-10
Power and Feedback Cables	D-11
Motor Power Cables	D-11
Motor Feedback Cables	D-12
Encoder Feedback Cables for 1326AB Motors	D-12
Miscellaneous Accessories	D-13

Preface

Read this preface to familiarize yourself with the rest of the manual. This preface covers the following topics:

- Who should use this manual
- The purpose of this manual
- Contents of this manual
- Related documentation
- Conventions used in this manual
- 1394 product receiving and storage responsibility
- Allen-Bradley support

Who Should Use this Manual

Use this manual if you are responsible for designing, installing, programming, or troubleshooting the Allen-Bradley 1394 family of products.

If you do not have a basic understanding of the 1394, contact your local Allen-Bradley representative for information on available training courses before using this product.

Purpose of this Manual

This manual is a user guide for the 1394. It gives you an overview of the 1394 family and describes the procedures you use to install, set up, use, and troubleshoot the 1394.

Contents of this Manual

Chapter	Title	Contents
	Preface	Describes the purpose, background, and scope of this manual. Also specifies the audience for whom this manual is intended.
1	Overview	Explains and illustrates the theory behind the 1394's operation. Covers hardware and software features.
2	Installing Your 1394 (applies to all systems)	Provides mounting information for your 1394 system.
3	Wiring System, Axis, and Shunt Modules, and Motors (for all systems)	Provides information on how to connect your 1394 system components together.
4	Wiring 1394 GMC and GMC Turbo Systems	Provides information on how to wire your 1394 GMC and GMC Turbo System Modules.
5	Wiring Your 1394 Analog Servo System	Provides information on how to wire your 1394 Analog Servo System Module.
6	Commissioning 1394 GMC and GMC Turbo Systems	Provides information about parameters used to configure your 1394 GMC and GMC Turbo.
7	Commissioning Your 1394 Analog Servo System	Provides information about parameters used to configure your 1394 Analog Servo Module.
8	Configuring Your 1394 Analog Servo System	Provides supplemental information on using communication tools.
9	Troubleshooting	Explains how to interpret and correct problems with your 1394 system.
Appendix A	Specifications	Provides physical, electrical, environmental, and functional specifications for the 1394.
Appendix B	Interconnect and CE Diagrams	Provides diagrams showing the interconnections for the available 1394 configurations and installation requirements to meet CE directives.
Appendix C	Using the Human Interface Module (HIM)	Provides information that will help you to use the HIM.
Appendix D	Catalog Numbers	Provides catalog number descriptions of 1394 and related products.

Related Documentation

The following documents contain additional information concerning related Allen-Bradley products. To obtain a copy, contact your local Allen-Bradley office or distributor.

For:	Read This Document:	Document Number:
A description and specifications for the 1394 family	1394 Digital, AC, Multi-Axis Motion Control System Product Data	1394-2.0
A description and specifications for the 1326ATorque Plus Motors used with the 1394	1326AB 460V, Torque Plus Series, AC Servo Motors Product Data	1326A-2.9
A description and specifications for the 1326A Rare Earth Motors used with the 1394	1326AS Series 460V, Low Inertia, Brushless Servo Motors Product Data	1326A-2.10
Product information regarding cables used with the 1326AB and 1326AS motors	1326 Cables for 460V AC Servo Motors	1326A-2.11
A user guide for GML™ programming to be used with the 1394 GMC System.	GML Commander Reference Manual	GMLC-5.2
An overview of the Flex I/O™ products	Flex I/O Product Profile	1794-1.14
Specifications for the Flex I/O products	Flex I/O Product Data	1794-2.1
An overview of the PanelView™ 550/600 product	PanelView 550/600 Product Profile	2711-1.13
An overview of the 9/Series products	9/Series CNC Product Profile	8520-1.3
A manual that provides you information on RIO communications	Installation Guidelines for the Twinaxial Cable	92-D1770-BCO
A manual that assists you with integrating and maintaining the 9/Series to be used with the 1394 CNC Interface System	9/Series Integration and Maintenance Manual	8520-6.2
An article on wire sizes and types for grounding electrical equipment	National Electrical Code	Published by the National Fire Protection Association of Boston, MA.
A glossary of industrial automation terms and abbreviations	Allen-Bradley Industrial Automation Glossary	AG-7.1

Conventions Used in this Manual

The following conventions are used throughout this manual:

- Bulleted lists such as this one provide information, not procedural steps.
- Numbered lists provide sequential steps or hierarchical information.
- Words that you type or select appear in bold.
- When we refer you to another location, the section or chapter name appears in italics.

Module Series Designator

To determine the series designator, check the series field on the Allen-Bradley label attached to your system, axis, and shunt modules. The series designator is located as shown in the example below.

Figure P.1
Allen-Bradley Label

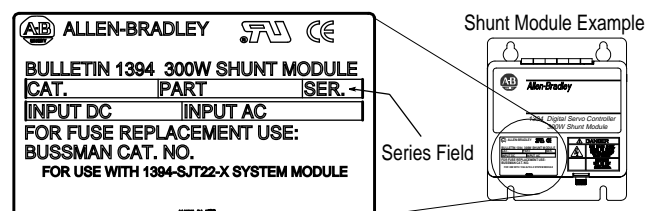

1394 Product Receiving and Storage Responsibility

You, the customer, are responsible for thoroughly inspecting the equipment before accepting the shipment from the freight company. Check the item(s) you receive against your purchase order. If any items are obviously damaged, it is your responsibility to refuse delivery until the freight agent has noted the damage on the freight bill. Should you discover any concealed damage during unpacking, you are responsible for notifying the freight agent. Leave the shipping container intact and request that the freight agent make a visual inspection of the equipment.

Leave the product in its shipping container prior to installation. If you are not going to use the equipment for a period of time, store it:

- in a clean, dry location
- within an ambient temperature range of 0 to 65° C (32 to 149° F)
- within a relative humidity range of 5% to 95%, non-condensing
- in an area where it cannot be exposed to a corrosive atmosphere
- in a non-construction area

Allen-Bradley Support

Allen-Bradley offers support services worldwide, with over 75 Sales/Support Offices, 512 authorized Distributors and 260 authorized Systems Integrators located throughout the United States alone, plus Allen-Bradley representatives in every major country in the world.

Local Product Support

Contact your local Allen-Bradley representative for:

- sales and order support
- product technical training
- warranty support
- support service agreements

Technical Product Assistance

If you need to contact Allen-Bradley for technical assistance, please review the information in the *Troubleshooting* chapter first. Then call your local Allen-Bradley representative. For the quickest possible response, please have the catalog numbers of your products available when you call.

Overview

The 1394 System

The 1394 is a modular, multi-axis motion control and drive system family. Its unique design allows the 1394 to be used as an integrated motion controller and drive system (GMC) with Turbo or standard IMC™ S Class Compact functionality, an integrated 9/440 CNC system, a 9/Series CNC digital interface drive system, a SERCOS servo drive system, or an analog servo drive system.

All 1394 systems provide direct line connection (transformerless) for 360 and 480V three-phase input power, efficient IGBT power conversion, and slide-and-lock, module-to-module connection systems. Each system module can be configured with up to four axis modules, with each axis module interfacing to a motor. The 1394 provides significant panel space and interconnect savings.

Series Note

Series C system modules (catalog numbers 1394C-SJT $xx-x$) and axis modules (catalog numbers 1394C-AM xx and -AM xx -IH) include features not available on Series A and B modules (catalog numbers 1394-SJT $xx-x$ and 1394-AM xx).

System Module Features:	Feature Availability	
	Series C	Series A and B
Connector (plug-in) input power termination	Yes	No
Cable Clamp (strain relief, shield bond)	Yes	No
EMI filter (24V input power, registration)	Yes	No
Smart Power (Soft Start, power monitor)	Yes	22 kW systems only

Axis Module Features:	Feature Availability	
	Series C	Series A and B
Cable Clamp (strain relief, shield bond)	Yes	No
EMI filter (motor brake and thermal circuit)	Yes	No

Series C system modules are interchangeable with Series A and B. Likewise, Series A, B, and C axis modules are interchangeable with each other.

Series C is recommended for all new applications. See the tables above for feature availability. For help in determining the series of your module(s), refer to the section *Module Series Designator* in the *Preface*.

Safety Precautions

The following general precautions apply to the 1394:



ATTENTION: Only those familiar with the 1394 Digital, AC, Multi-Axis Motion Control System and associated machinery should plan or implement the installation, startup, and subsequent maintenance of the system. Failure to comply can result in personal injury and/or equipment damage.

ATTENTION: This product contains stored energy devices. To avoid hazard of electrical shock, wait five minutes after removing power or verify that all voltage on the capacitors has been discharged before attempting to service, repair, or remove this unit. You should only attempt the procedures in this manual if you are qualified to do so and familiar with solid-state control equipment and the safety procedures in publication NFPA 70E.

ATTENTION: The system integrator is responsible for local safety and electrical codes.



ATTENTION: An incorrectly applied or installed drive can result in component damage or a reduction in product life. Wiring or application errors, such as undersizing the motor, incorrect or inadequate AC supply, or excessive ambient temperatures can result in malfunction of the drive.

ATTENTION: This drive contains ESD (Electrostatic Discharge) sensitive parts and assemblies. Static control precautions are required when installing, testing, servicing, or repairing this assembly. Component damage can result if ESD control procedures are not followed. If you are not familiar with static control procedures, refer to Allen-Bradley publication 8000-4.5.2, Guarding Against Electrostatic Damage or any other applicable ESD Protection Handbook.

1394 System Overview

GMC System

The 1394 GMC System provides all the functionality of the IMC S Class Compact Motion Controller and power conversion within the 1394 system module. Allen-Bradley offers two versions of the 1394 GMC system module (Standard GMC and GMC Turbo). Both systems are completely programmed and commissioned using GML™ (Graphical Motion Control Language), offer Allen-Bradley DH485, RS-232, and RS-422 as standard communications, and have Remote I/O and AxisLink available as communication options.

The 1394_x-SJT_{xx}-C (Standard GMC) system supports four axis modules and provides four channels of auxiliary encoder input. The 1394C-SJT_{xx}-L (Standard GMC) provides the same functionality of the 1394_x-SJT_{xx}-C, but supports only one axis module and provides two channels of auxiliary encoder input.

In addition, the 1394_x-SJT_{xx}-T (GMC Turbo) provides more GML application program memory and executes the programs faster. The 1394_x-SJT_{xx}-T offers 64K of memory with a 32-bit processor while the 1394_x-SJT_{xx}-C offers 32K of program memory with a 16-bit processor. The 1394_x-SJT_{xx}-T also includes a direct, high speed link to the SLC 5/03™, 5/04™, or 5/05™ that simplifies the programming required to transfer data between the 1394_x-SJT_{xx}-T and the SLC™.

Figure 1.1
Two GMC Turbo Systems (1394_x-SJT_{xx}-T)

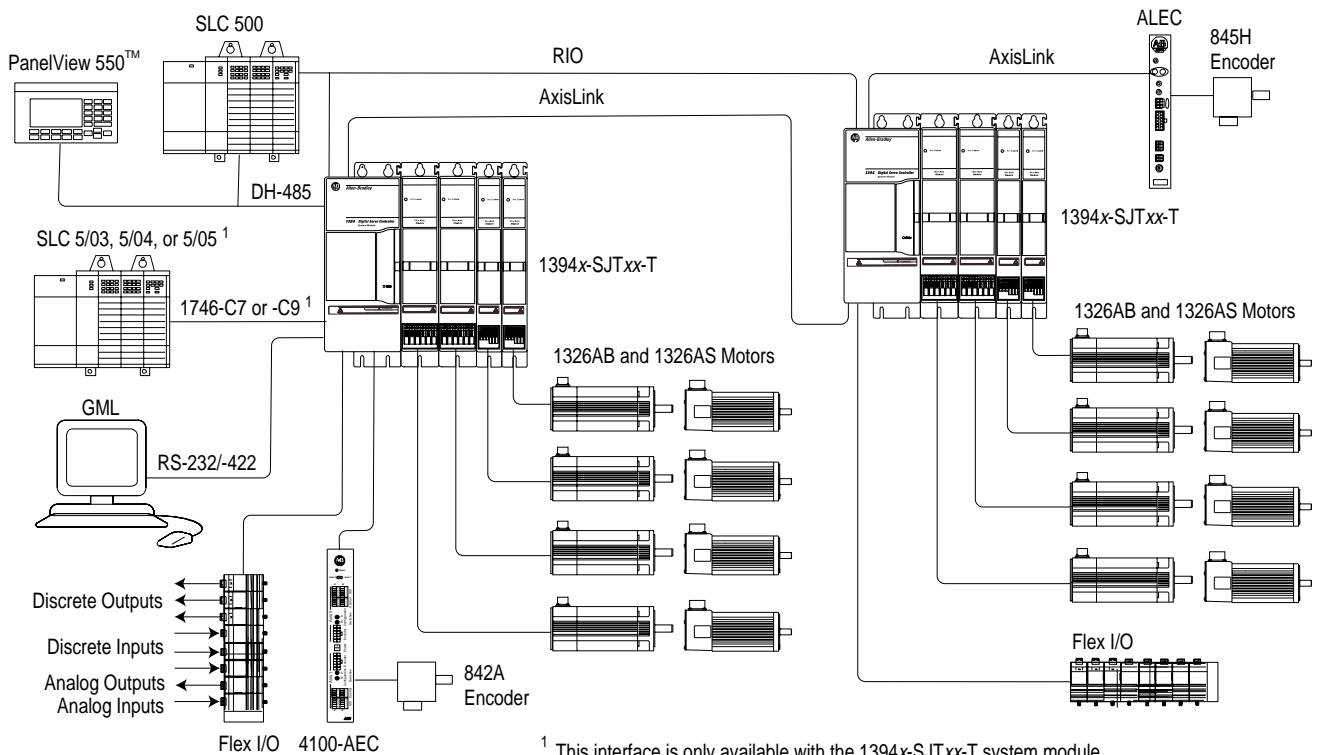
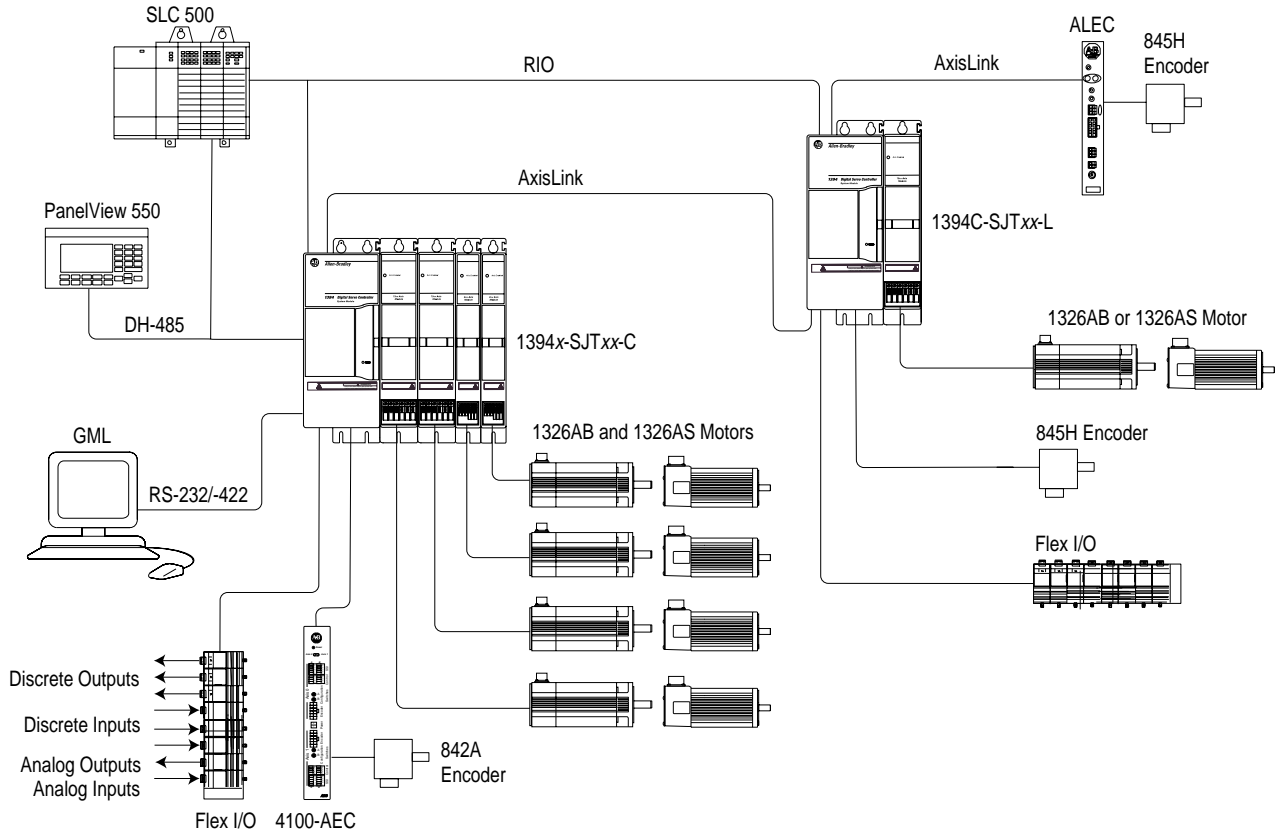

Figure 1.2
Two Standard GMC Systems (1394x-SJTxx-C and 1394C-SJT-xx-L)



CNC Interface System

The 1394 9/Series CNC Interface system (1394-SJT_{xx}-E) provides a digital servo system to be used with the 9/260 and 9/290 CNC. This system provides all power electronics and uses a cost-saving digital interface approach. Servo control for this system is handled by the 9/ Series CNC. A fiber optic I/O ring is provided to the 1394 and the system is completely interfaced with and programmed using ODS (Off-Line Development System) and the CNC operator panel. Allen-Bradley Remote I/O, MMS/Ethernet (9/260 and 9/290 only), and Data Highway Plus™ (9/260 and 9/290 only) communications are available options with the 9/Series CNC interface system.

Figure 1.3
CNC Interface System

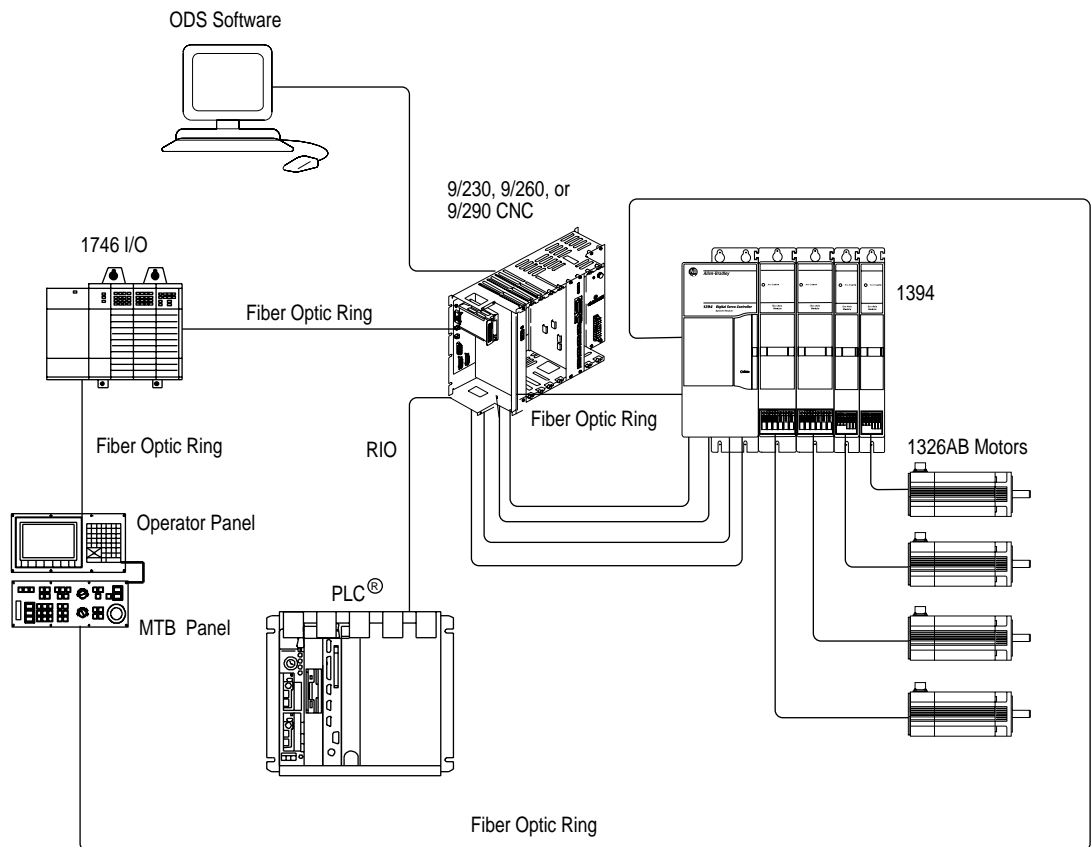

SERCOS System

The 1394 SERCOS system module (1394C-SJT_{xx}-D) provides a digital servo drive system with a fiber-optic digital network interface. It can be used as a velocity or torque control system and is quickly commissioned with the Allen-Bradley SERCOS Interface Module (Bulletin 1756 with 1756-M_{xx}SE), which provides access to auto tuning and start-up prompting. The 1394 also provides a SCANport™ interface as a standard feature.

For specific installation and wiring information refer to the *1394 SERCOS Multi-Axis Motion Control System User Manual* (publication 1394-5.20).

Figure 1.4
SERCOS System

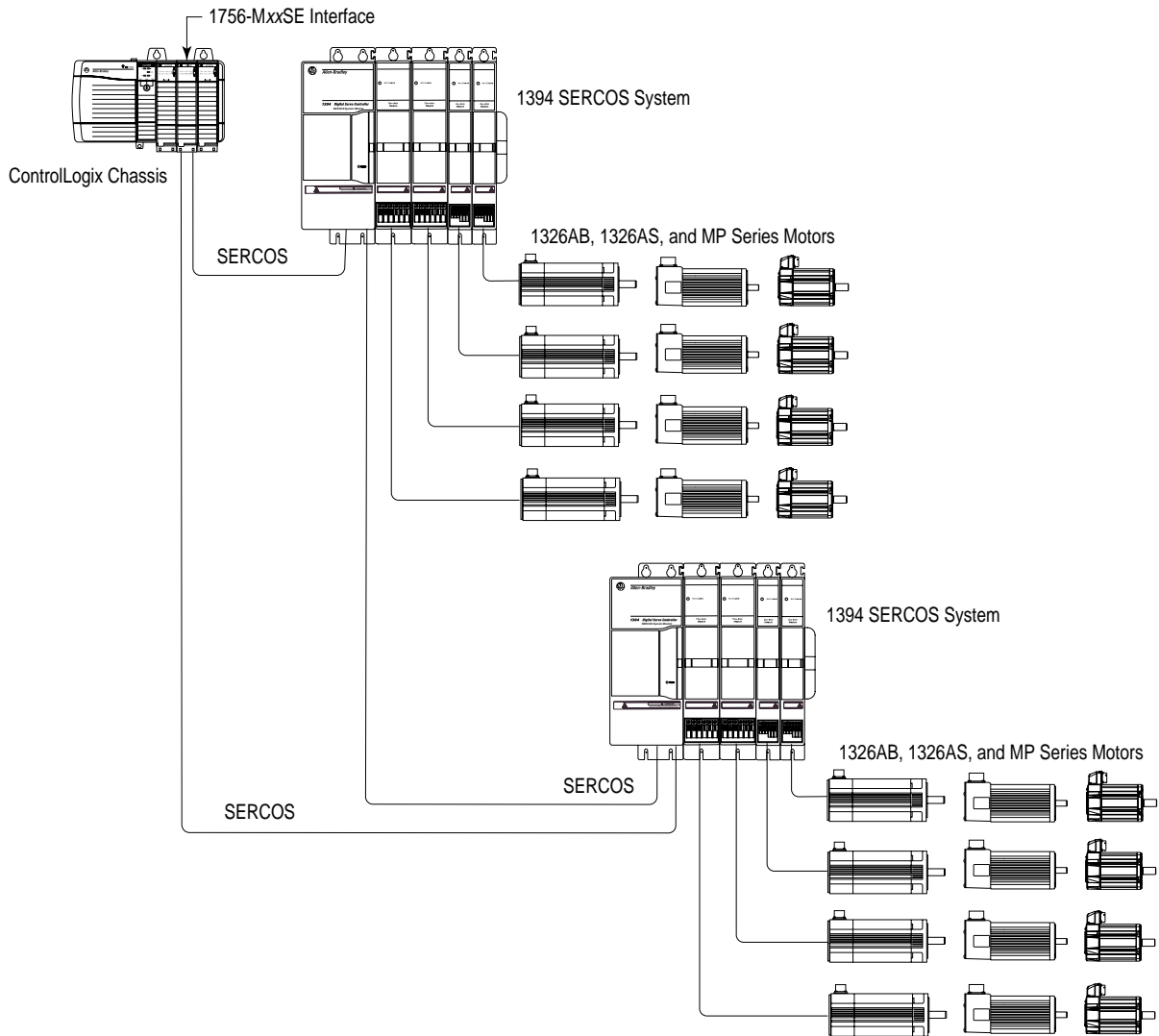

Analog Servo System

The 1394 Analog Servo system (1394x-SJTxx-A) provides a digital servo drive system with a traditional $\pm 10V$ DC analog interface. It can be used as a velocity or torque control system and is quickly commissioned with the Allen-Bradley universal Bulletin 1201 HIM (Human Interface Module), which provides access to auto tuning and start-up prompting. The 1394 also provides a SCANport interface as a standard feature.

Figure 1.5
Analog Servo System

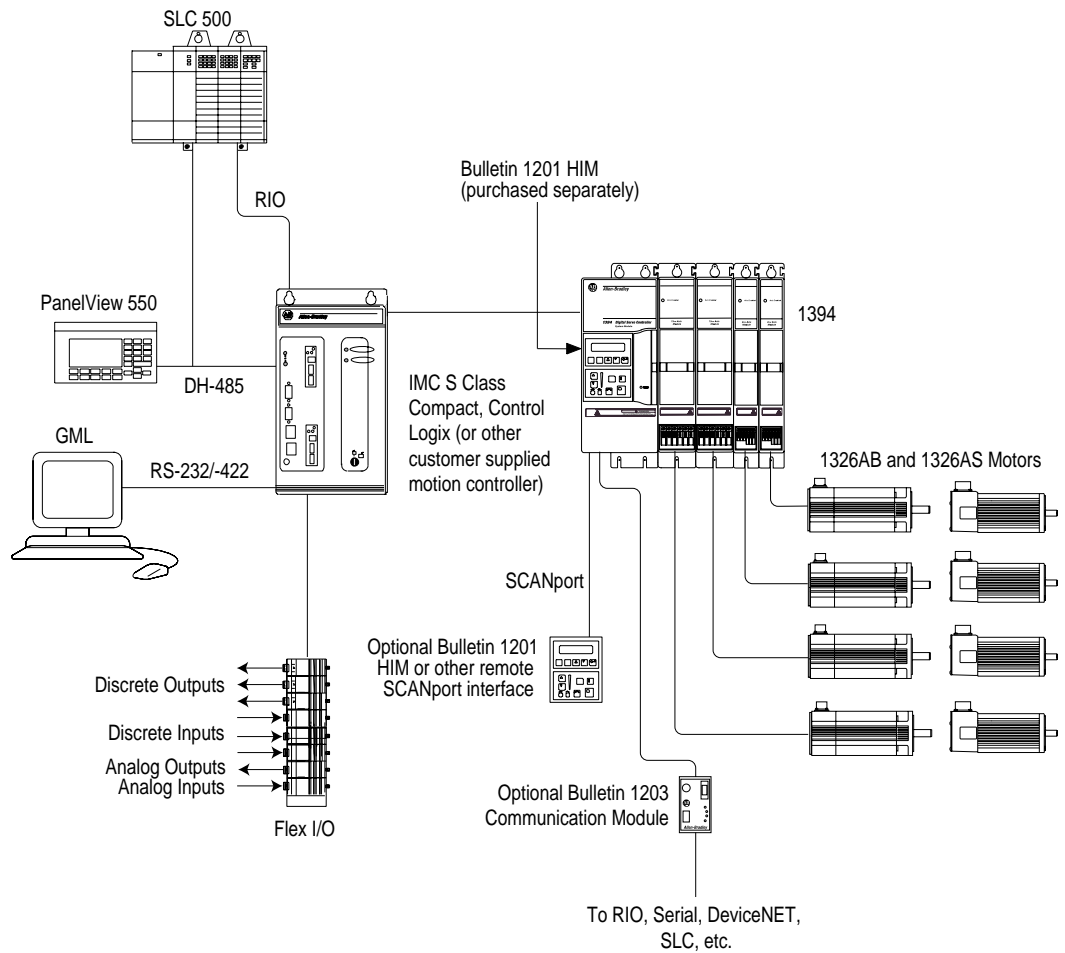

9/440 CNC System

The 9/440 CNC system module gives you all the power and programming capabilities of a 9-Series CNC, integrated into the compact packaging of the 1394 System Module. The 9/440 CNC System Module provides terminating points for:

- Resolvers
- Encoder feedback (for optional position feedback or spindle control)
- Two serial ports (for communicating with the 9-Series ODS or other peripherals such as printers or tape readers)
- E-STOP string and status
- Spindle outputs
- 9-Series fiber optic ring connection
- Touch probe interface
- Remote I/O connection

There are three versions of the 9/440 CNC System:

Version:	Catalog Number:	Number of			
		Axis modules:	Resolver feedback ports:	Analog outputs:	Encoder feedback ports:
1 Axis 9/440	8520-1Sx	1	1	2	0
3 Axis 9/440	8520-3Sx	3	3 ¹	2	1 ¹
4 Axis 9/440	8520-4Sx	4	4 ²	2	3 ²

¹ You can connect a total of three feedback devices. If you use three resolvers, the encoder port (J11) is not available. If you use the encoder feedback port (J11), the third resolver feedback (J3) is disabled.

² You can connect a total of six feedback devices. If you use four resolvers, the last encoder port (J11) is not available. If you use all three encoder feedback ports, the third resolver feedback (J3) is disabled.

For more information on the 9/440, refer to the *9-Series Integration and Maintenance Manual* (publication 8520-6.2).

Figure 1.6
9/440 System

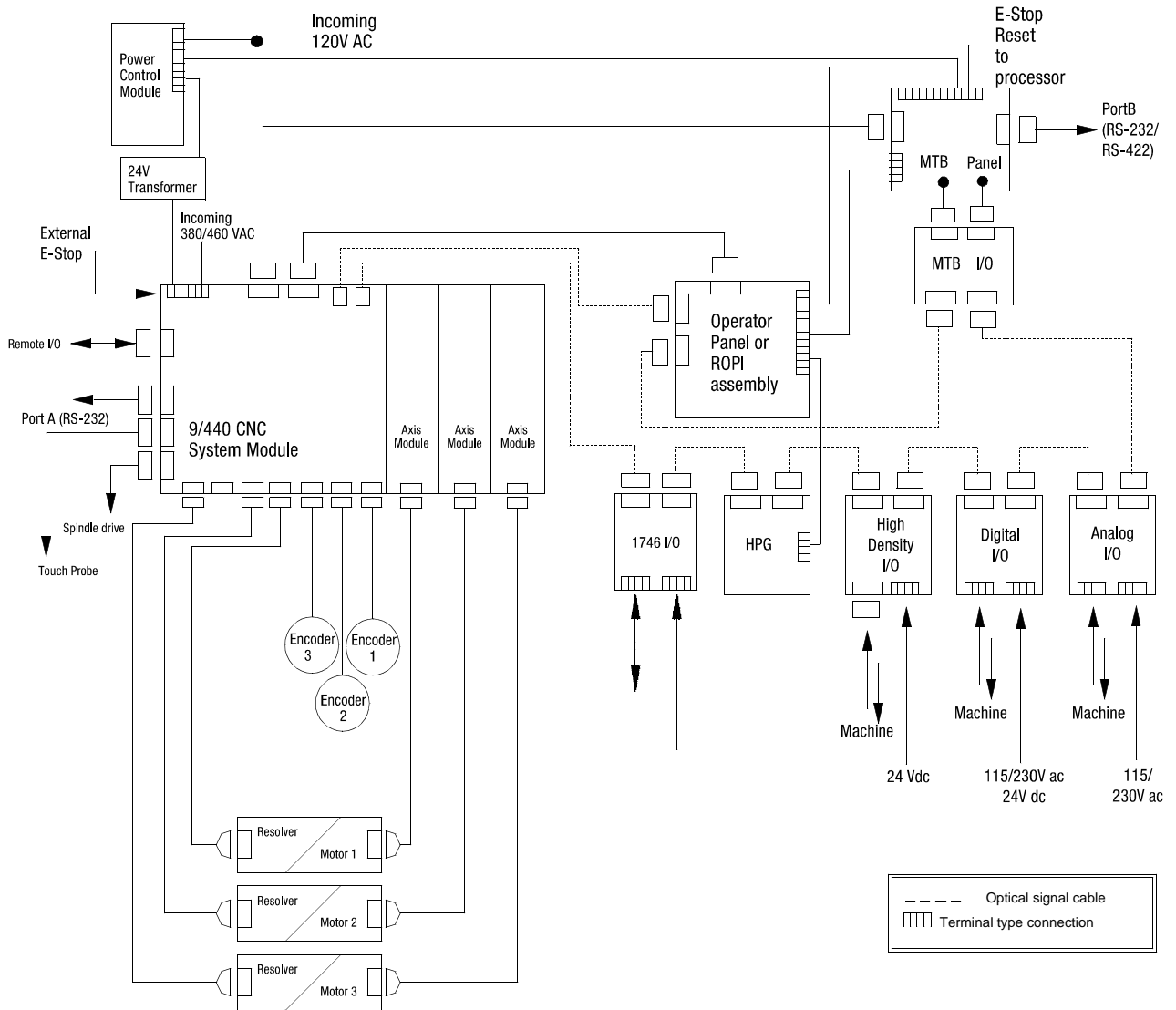

What is a 1394 System?

The 1394 system consists of the following components (catalog number appears in parenthesis):

- One System Module (1394x-SJTxx-x)
- One to four Axis Modules (1394x-AMxx-xx)
- One to four servo motors (1326Ax-Bxxxx)
- One to four power and feedback cables

Also available are the DC Link Module (1394-DCLM) and Drive Interface Module (1394-DIM).

The:	Is used:
1394-DCLM	In addition to the axis module(s)
1394-DIM	In place of an axis module.

Axis modules are connected to system modules using slide-and-lock, module-to-module connections. For information on motors and cables, refer to the *1326AB 460V, Torque Plus Series, AC Servo Motors Product Data* (publication 1326A-2.9), *1326AS Series 460V, Low Inertia, Brushless Servo Motors Product Data* (publication 1326A-2.10), and *1326 Cables for 460V AC Servo Motors Product Data* (publication 1326A-2.11).

In addition to the equipment shown above, you will need to supply the following:

- Three phase input contactor
- Three phase input fusing
- 24V AC or DC logic power for system module and contactor enable (Analog Servo only)/DRIVEOK power (all modules)

Refer to *Appendix A* for information on these topics.

Note: An external shunt resistor kit (1394-SR10A) is available for 5 and 10 kW systems with regenerative loads that exceed the capacity of the internal 200W shunt resistor provided. Most 5 and 10 kW systems will not require a shunt resistor kit. All 22 kW 1394 based products require an external shunt module (1394-SR9Ax or 1394-SR36Ax). This includes both 1394 and 8520 catalog items.

System Modules

System modules, available with ratings of 5, 10 and 22 kW (at 460V), house the system control PCB and convert 360 to 480VAC, three-phase, 50/60 Hz input power to a 530 - 680V DC link voltage. The 5 and 10 kW system modules have an internal shunt resistor with a 200W continuous rating and a peak rating of 40,000W. The 22 kW system module requires an external shunt module.

Figure 1.7
1394 System module

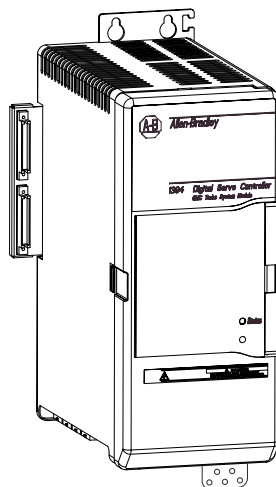

Axis Modules

Axis modules, with continuous output currents (RMS) of 3.0, 4.5, 7.5, 23.3 and 35.0A, convert the DC power supplied by the system module to a variable AC voltage. You will require one axis module for every 1326Ax-Bxxxx servo motor you plan to run using the 1394. Choose each axis module based on the current requirements of the servo motor.

Figure 1.8
1394 Axis Module

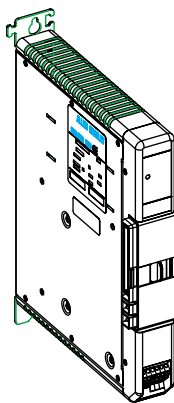

External Shunt Module (used with 22 kW System)

Shunt modules with (rms) power output of 300, 900, 1800 and 3600W continuous, 160,000W peak are available for use with the smart power 22 kW system module. The shunt module dissipates excess regenerative power from the Bulletin 1394 system. You must use one shunt module with each 22 kW smart power system module. Available in two sizes, each package contains an integral fuse and terminal block. The 3600W package is available with a 115/230V AC cooling fan. Choose your shunt module based on the shunt requirements of the 1326Ax-Bxxxx servo motors you plan to run using the 1394.

Note: 5 and 10 kW system modules can use an optional 1400W shunt module kit to dissipate excess regenerative energy (unpackaged components).

Figure 1.9
1394 External Shunt Module

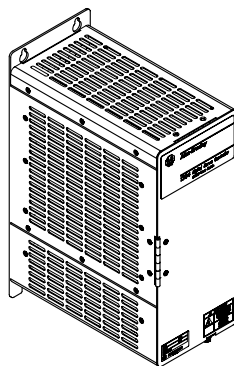

1326AB Motors

This family of high-performance, medium inertia, ferrite, three-phase servo motors feature a specially designed housing that reduces motor length. They are available with continuous torque ratings of 2.3 to 53.0 N-m (20.7 to 469.0 lb-in.). Refer to the *1326AB 460V, Torque Plus Series, AC Servo Motors Product Data* (publication 1326A-2.9) for more information on features and options. IP65 protection rating is standard when used with the shaft oil seal kit. IP67 protection rating is available (specify -L in the catalog number, refer to *Appendix D*).

Figure 1.10
1326AB Motor

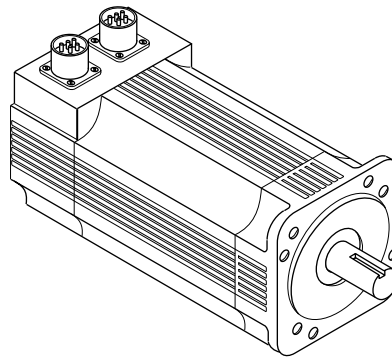

1326AS Motors

This family of high-performance servo motors feature neodymium-iron-boron permanent magnet rotors that provide low inertias, high accelerations and high peak torques. They are available with continuous torque ratings of 0.49 to 49.3 N-m (4.33 to 436 lb-in.). Refer to the *1326AS Series 460V, Low Inertia, Brushless Servo Motors Product Data* (publication 1326A-2.10) for more information on features and options. IP65 protection rating is standard when used with the shaft oil seal.

Important: 1326AS-Bxxxx motors cannot be used with the 9/Series and 9/440 controllers.

Figure 1.11
1326AS Motor

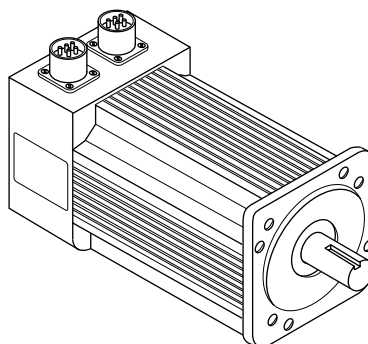

1326AH Motors

This family of hazardous duty motors are UL recognized AC brushless servo motors. Construction of the motor is a totally enclosed non-ventilated (TENV) square frame design utilizing a permanent magnet rotor and a fixed stator winding. Rare earth magnets, long life ball bearings, and brushless construction also assures maximum performance. They are available with continuous torque ratings of 2.97 to 16.9 N-m (26.3 to 149.8 lb-in.). Refer to the *1326AH Hazardous Duty Motors Product Data* (publication 1326AH-TD001B-US-P) for more information.

Figure 1.12
1326AH Motor

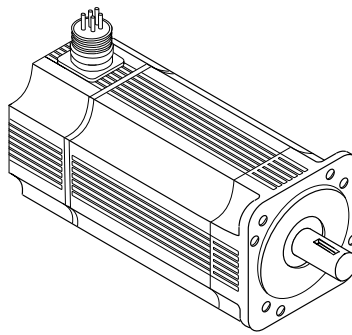

Drive Interface Module

The 1394-DIM (Drive Interface Module) provides four channels of analog output, four drive enable outputs, and four drive fault inputs. The 1394-DIM allows the 1394x-SJTxx-C, -T, or -L system module to be used to control any external drive with a $\pm 10V$ velocity torque reference command and quadrature encoder output. Each 1394-DIM can support up to four drives. However, the maximum number of axes (1394-DIM controlled drives plus 1394x-AMxx axis modules) cannot exceed four per 1394x-SJTxx-C or -T system module and one per 1394C-SJTxx-L system module. The 1394-DIM is not compatible with the 1394x-SJTxx-A system module.

Figure 1.13
Drive Interface Module

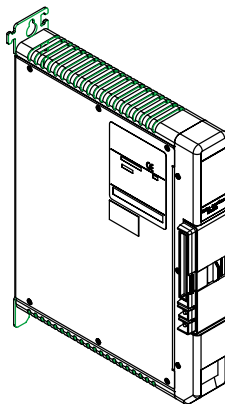

DC Link Module

The 1394-DCLM (DC Link Module) provides additional load leveling and energy storage (capacitance) for 1394 systems. This allows additional regenerative energy to be stored during the machine cycle, increasing system capacity, lowering cycle time, and avoiding resistive heat loss. The module can be used alone or two modules can be used to interconnect two 1394 systems using the DC Link cable.

Figure 1.14
DC Link Module

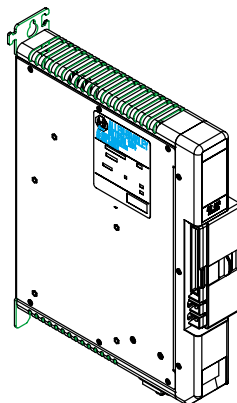

Standard Features of the 1394

The 1394 provides the following standard features:

- UL Listed and CUL Certified
- CE Marked

Control

- Supports Standard GMC (1394x-SJTxx-C and -L) and GMC Turbo, CNC Interface, SERCOS, and Analog Servo configurations with a standard array of hardware.
- Digitally-adjusted velocity and current loop compensation, which accommodates a wide range of system inertias.
- Two configurable analog test outputs that can be linked to critical system parameters for troubleshooting (GMC and Analog Servo system modules).
- All systems provide digital fault and diagnostic utilities (including a current monitor, thermal overload detection, and a feedback signal monitor).
- Status LEDs for system and axis modules.
- Status LEDs for motion board, Axislink, and RIO (GMC system only).
- Highly-integrated surface mount circuitry.
- Encoder signal output (A QUAD B) for encoder emulation (Analog Servo system modules only).
- DSP assisted processing.
- Smart Power control, available on all 22 kW system modules and 5 and 10 kW system modules (Series C or later), allows power-use monitoring for process optimization.
- Smart Power system modules, available on all 22 kW system modules and 5 and 10 kW system modules (Series C or later), include active Soft Start inrush current limiting for DC link charging.
- Electrical Noise Protection included on GMC, GMC Turbo, SERCOS, and Analog Servo system modules (Series C or later) and axis modules (Series C or later).
- Improved grounding terminations on GMC, GMC Turbo, SERCOS, and Analog Servo system modules (Series C or later) and axis modules (Series C or later).

Note: To determine the series of your module, refer to Figure P.1 in the *Preface*.

Power

- IGBT technology for efficient, quiet operation.
- Transient (MOV) voltage, phase loss, and ground fault protected input.
- An integral 200W shunt resistor is available (5 and 10 kW only). An external 1400W shunt kit is available (5 and 10 kW only). Other external shunt kits and modules from 300 to 3600W continuous.
- Current ratings of 3.0, 4.5, and 7.5A continuous, at 50° C (122° F) (inside cabinet) and 23.3 and 35A continuous, at 40° C (104° F) (with heat sinks out the back) with up to 300% motor ratings for high duty-cycle operation producing continuous torque ranges of 0.7 to 53.0 N-m (6 to 469 lb-in.).
- 324-528V AC, three-phase, 50/60 Hz direct line operation.
- No isolation transformer or inductors are required (360/480VAC Hz direct line operation) for most applications.
- Advanced protective features, such as software-based current foldback, which provides overload tolerant operation and soft current limiting.

Integration

- Hinged system module front cover for easy access to control and power wiring.
- System and axis modules that can be quickly removed and easily interchanged for troubleshooting and diagnostics.
- Standard widths of 50 mm (1394x-AM03, -04, and -07) and 75 mm (1394x-AM50-xx and -AM75-xx) axis modules are available.
- Mass termination plugs and reliable, contact-type, terminal blocks are used for easy installation and service.
- Plug interconnects for auxiliary, encoder input (GMC), encoder output and motor resolver input (all).
- Slide-and-lock, module-to-module connection, which eliminates bus bars and wiring harnesses.
- Advanced communications and I/O capabilities help integrate the 1394 to standard plant floor networks.

Installing Your 1394 (applies to all systems)

Chapter Objectives

This chapter covers the following topics:

- Complying with European Union directives
- Before mounting your system
- Unpacking your modules
- System mounting requirements
- Bonding your system
- Mounting your 1394 system
- Mounting your 1394-DCLM
- Mounting the external shunt resistor for 5 and 10 kW system modules
- Mounting external shunt modules for 22 kW system modules
- Mounting considerations for GMC and GMC Turbo systems



ATTENTION: The following information is a guideline for proper installation. The National Electrical Code and any other governing regional or local codes overrule this information. The Allen-Bradley Company cannot assume responsibility for the compliance or the noncompliance with any code, national, local or otherwise, for the proper installation of this system or associated equipment. If you ignore codes during installation, hazard of personal injury and/or equipment damage exists.

Complying With European Union Directives

If this product is installed within the European Union or EEC regions and has the CE mark, the following regulations apply.

EMC Directive

This unit is tested to meet Council Directive 89/336 Electromagnetic Compatibility (EMC) using a technical construction file and the following standards, in whole or in part:

- EN 5008x-2 EMC - Emission Standard, Part 2 - Industrial Environment
- EN 5008x-2 EMC - Immunity Standard, Part 2 - Industrial Environment

The product described in this manual is intended for use in an industrial environment.

To meet CE requirements, the following additions are required:

- You must run three-phase input wiring in a conduit that is grounded to the enclosure.
- You must install a power line filter (Allen-Bradley catalog number SP-74102-006-01, SP-74102-006-02, SP-74102-006-03 or equivalent based on system current) between the three-phase input line and the system module input.
- You must terminate the shields of the motor power cables and the motor feedback cables to the enclosure at the point of entry.

Low Voltage Directive

These units are tested to meet Council Directive 73/23/EEC Low Voltage Directive. The *EN 60204-1 Safety of Machinery-Electrical Equipment of Machines, Part 1-Specification for General Requirements* standard applies in whole or in part.

Refer to *Appendix B* for interconnect information.

Before Mounting Your System

Before you mount your 1394 system make sure you understand the following:

- how to store your 1394 before installation
- how to unpack the system and axis modules
- the minimum mounting requirements
- how to determine your mounting hole layout

Storing Your 1394 Before Installation

The 1394 System module and Axis modules should remain in their shipping containers prior to installation. If the equipment is not to be used for a period of time, store it as follows:

- Store the equipment in a clean, dry location that is not exposed to a corrosive atmosphere.
- Do not store equipment in a construction area.
- Store within an ambient temperature range of 0 to 65° C (32 to 149° F).
- Store within a relative humidity range of 5 to 95%, noncondensing.

Unpacking Modules

Each 1394 System module ships with the following:

- One system module
- One system terminator
- One terminal operating tool (part number 1394-194)
- One user manual (publication 1394-5.0)
- One application program lock key (GMC and GMC Turbo only)
- Mating power connectors (5 and 10 kW Series C only)
- Cable shield grounding clamps (5, 10, and 22 kW Series C only)

Note: To determine the series of your module, refer to Figure P.1 in the *Preface*.

Each 1394 Axis Module ships with the following:

- One 1394 Axis module
- TB1 and TB2 connectors
- One 1394 Axis module information sheet (publication 1394-5.5)

Remove all packing material, wedges, and braces from within and around the components. After unpacking, check the item(s) nameplate catalog number against the purchase order. Refer to *Appendix D* for more information on catalog numbers.

System Mounting Requirements

There are several things that you need to take into account when preparing to mount the 1394:

- The ambient temperature of the location in which you will install the 1394 must not exceed 50° C (122° F).
- You must install the panel on a flat, rigid, vertical surface that won't be subjected to shock, vibration, moisture, oil mist, dust, or corrosive vapors.
- You have to mount the system vertically.
- You need to maintain minimum clearances (see Figure 2.1) for proper airflow, easy module access, and proper cable bend radius.

Refer to *Appendix A* for mounting dimensions, power dissipation, and environmental specifications for the 1394.



ATTENTION: This drive contains ESD (Electrostatic Discharge) sensitive parts and assemblies. You are required to follow static control precautions when you install, test, service, or repair this assembly. If you do not follow ESD control procedures, components can be damaged. If you are not familiar with static control procedures, refer to Allen-Bradley publication 8000-4.5.2, *Guarding Against Electrostatic Damage* or any other applicable ESD Protection Handbook.

Figure 2.1
Minimum System and Axis Module Mounting Requirements

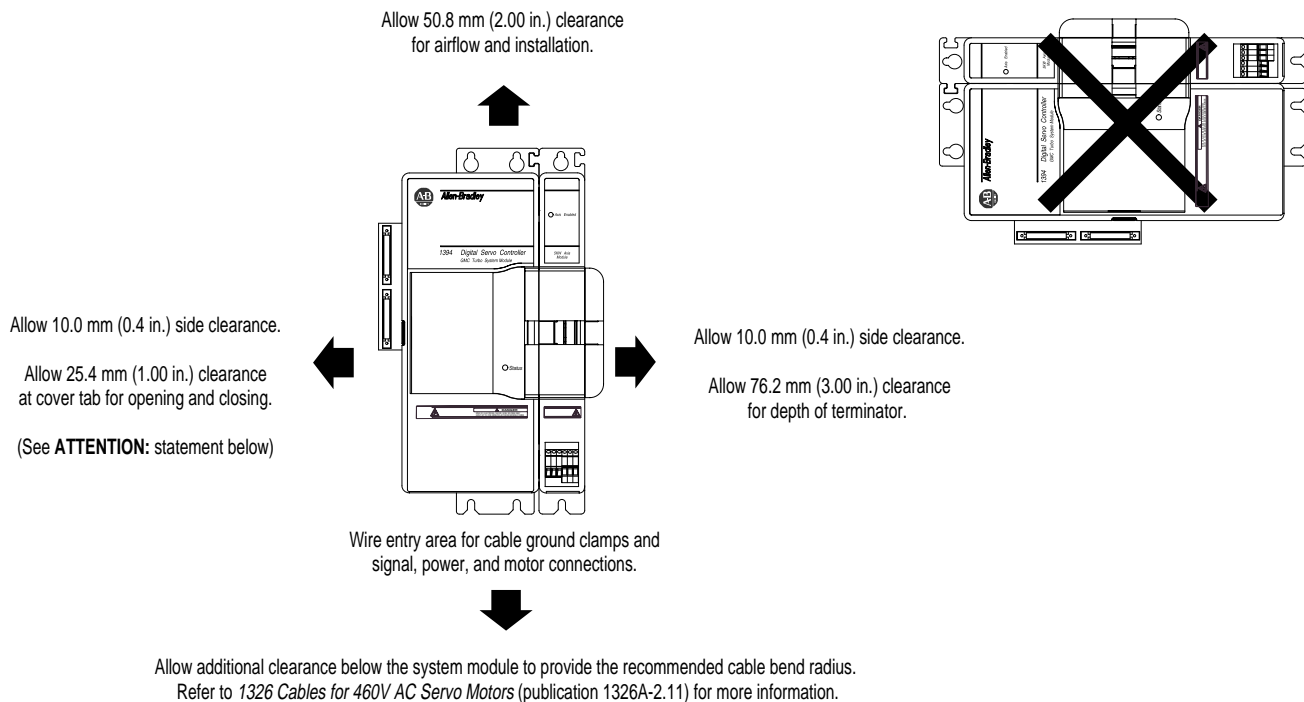

ATTENTION: If you are mounting a 1394x-SJTxx-T system module, and using the SLC Interface, you will need an additional 101.6 mm (4 in.) of clearance to the left of the system module to allow for connecting the SLC interface cable (1746-C7 or -C9).

Determining Your System Mounting Hole Layout

To prepare your subpanel for mounting:

1. Before you mount your 1394 System, use the illustration and table on the next page to identify your axis module combination.

Figure 2.2
1394 Mounting Hole Layout

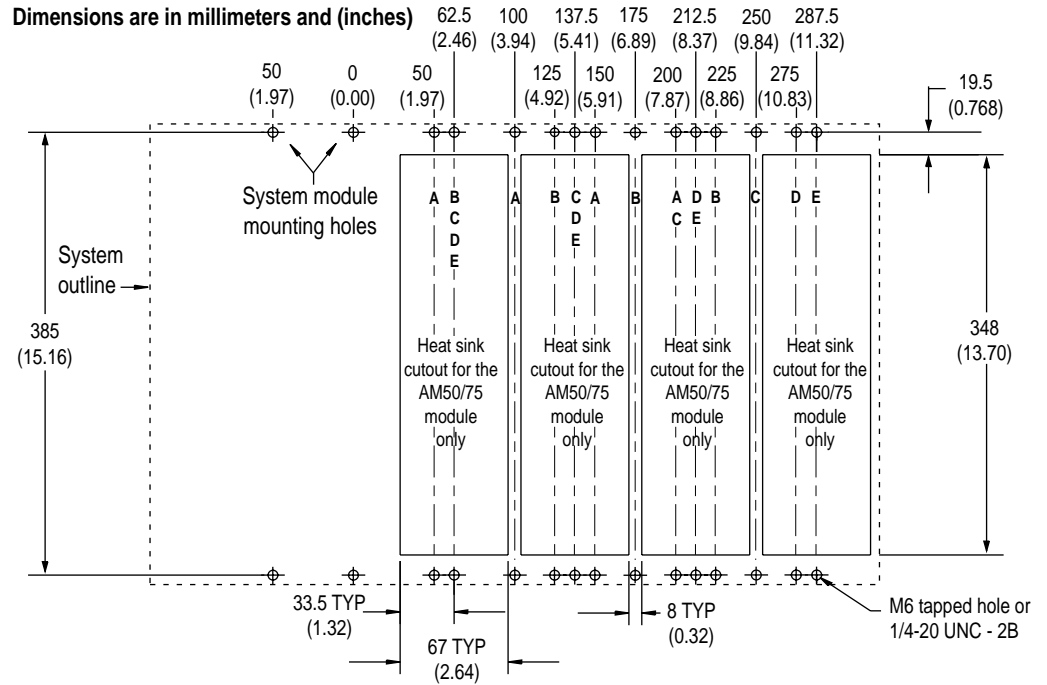

Axis Module Combination	Type of Axis Module	Number of Axes	Cutout Needed?
A	1394x-AM50, or -AM75, and 1394C-AM50-IH, or -AM75-IH	0	no
	1394x-AM03, AM04, or AM07	up to 4	no
B	1394x-AM50, or -AM75, and 1394C-AM50-IH, or -AM75-IH	1	yes (1394x-AM50 or -AM75) no (1394C-AM50-IH or -AM75-IH)
	1394x-AM03, AM04, or AM07	up to 3	no
C	1394x-AM50, or -AM75, and 1394C-AM50-IH, or -AM75-IH	2	yes (1394x-AM50 or -AM75) no (1394C-AM50-IH or -AM75-IH)
	1394x-AM03, AM04, or AM07	up to 2	no
D	1394x-AM50, or -AM75, and 1394C-AM50-IH, or -AM75-IH	3	yes (1394x-AM50 or -AM75) no (1394C-AM50-IH or -AM75-IH)
	1394x-AM03, AM04, or AM07	up to 1	no
E	1394x-AM50, or -AM75, and 1394C-AM50-IH, or -AM75-IH	4	yes (1394x-AM50 or -AM75) no (1394C-AM50-IH or -AM75-IH)

Note: When mounting axis module combinations, you must mount the 1394x-AM50, -AM75, -AM50-IH, and -AM75-IH closest to the system module and ahead of the 1394x-AM03, -AM04, and -AM07 axis modules.

- Once you have identified your axis module combination, modify your subpanel using the dimensions that correspond with the combination you chose in step one.
- Go to *Bonding Your System*.

Mounting Your 1394 Through the Back of the Cabinet

The figure below shows an example of the typical mounting of a 1394 system with 1394x-AM50 or -AM75 axis modules. The 1394x-AM50 and -AM75 have heatsinks that mount through the back of the electrical cabinet.

Figure 2.3
Mounting the 1394 with heatsinks through the back of the cabinet

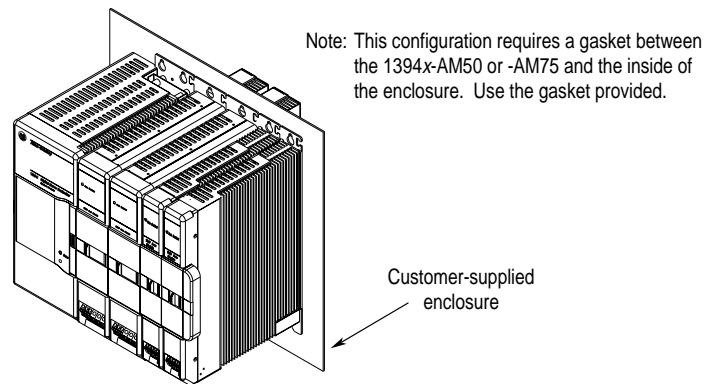

Bonding Your System

After you have established your panel layout, you need to understand how to bond your system and subpanels. Bonding is the practice of connecting metal chassis, assemblies, frames, shields and enclosures to reduce the effects of electromagnetic interference (EMI).

Bonding Modules

Unless specified, most paints are not conductive and act as insulators. To achieve a good bond between modules and the subpanel, the surfaces need to be paint-free or plated. Bonding metal surfaces creates a low impedance exit path for high frequency energy. Improper bonding blocks that direct exit path and allows high frequency energy to travel elsewhere in the cabinet. Excessive high frequency energy can effect the operation of other microprocessor controlled equipment. The illustrations below show details of recommended bonding practices for painted panels, enclosures and mounting brackets.

Figure 2.4
Bonding Examples

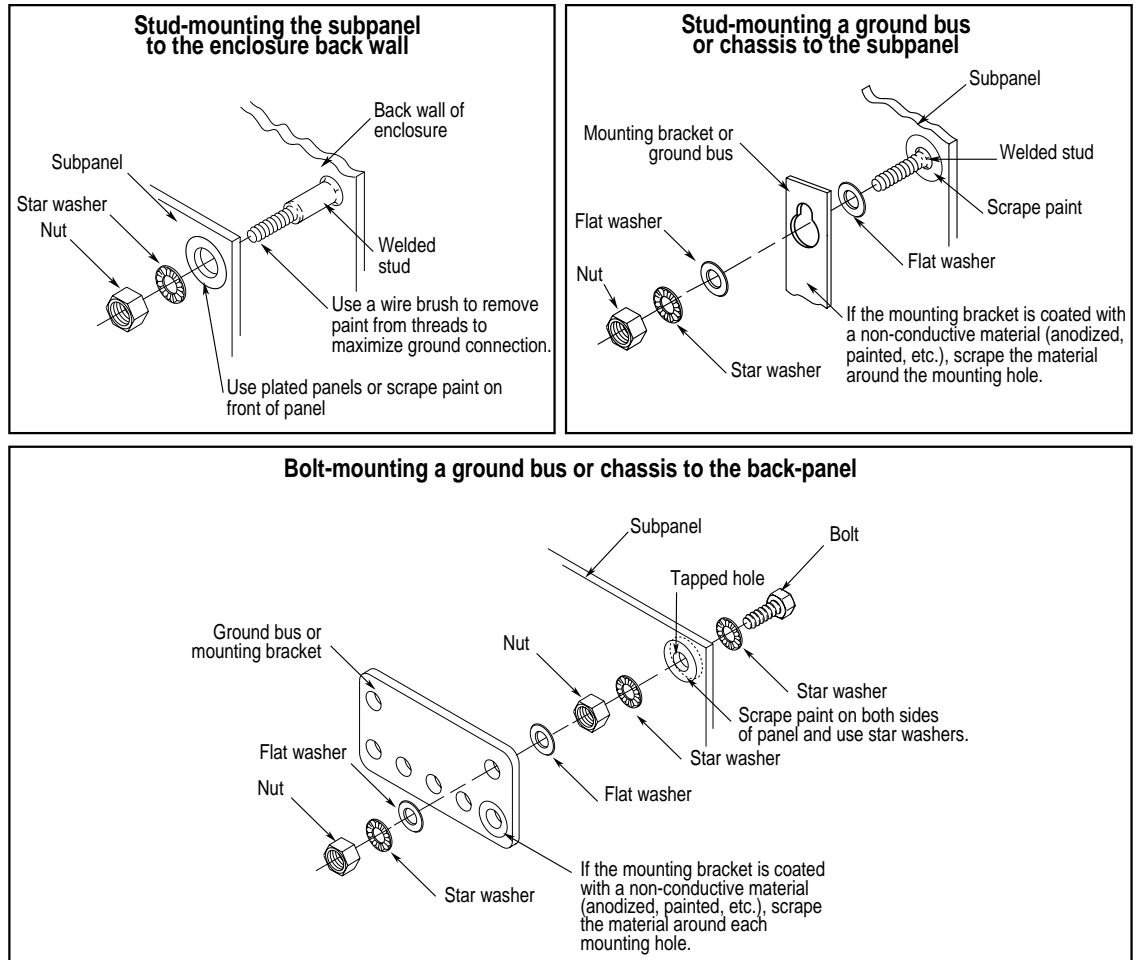

Bonding Multiple Subpanels

Bonding multiple subpanels creates a common low impedance exit path for the high frequency energy inside the cabinet. Subpanels that are not bonded together may not share a common low impedance path. This difference in impedance may affect networks and other devices that span multiple panels. Refer to the illustration below for recommended bonding practices.

Figure 2.5
Bonding Multiple Subpanels

Recommended:

Bond the top and bottom of each subpanel to the cabinet using 25.4 mm (1.0 in.) by 6.35 mm (.25 in.) (minimum) wire braid

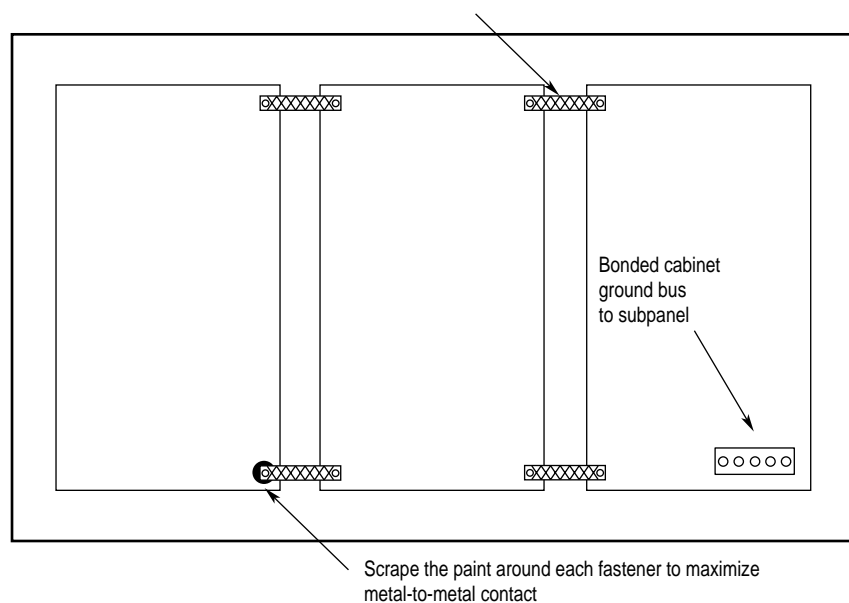

Mounting Your 1394 System

The procedures in this section assume you have prepared your panel and understand how to bond your system. To mount your 1394 system:

1. Install the top mounting fasteners on the subpanel for the system module and all axis modules. The heads of the fasteners should be at least 0.25 in. from the panel. Make sure all fasteners are properly bonded to the subpanel. Refer to *Bonding Your System* for more information.
2. Hang the 1394 System Module on the two fasteners on the left side of the subpanel.

Important: If you are mounting a GMC Turbo system module (1394x-SJTxx-T), and using the SLC interface, you will need an additional 101.6 mm (4 in.) of clearance to the left of the system module to allow for connecting the SLC interface cable (1746-C7 or -C9).

3.

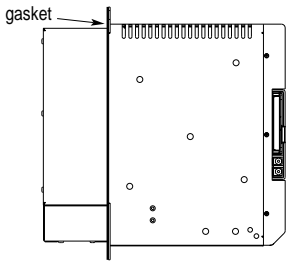
If you are mounting a:	Do this:
1394x-AM03, -AM04 or -AM07; 1394C-AM50-IH, or -AM75-IH axis module	<ol style="list-style-type: none"> 1. Hang the axis module on the next mounting fastener. 2. Go to main step 5.
1394x-AM50 or -AM75 axis module with the heat sink through the back of the enclosure (refer to Figure 2.3)	<ol style="list-style-type: none"> 1. Remove the paper backing from the gasket that came with the AM50/75 axis module. 2. Position the gasket so that the sticky side faces the axis module and the small hole side is on top. 3. Slide the gasket over the heat sink and attach it to the back of the axis module. <p data-bbox="1076 772 1247 831">Figure 2.6 Gasket Position</p>  <ol style="list-style-type: none"> 4. Go to main step 4.
1394-DCLM or 1394-DIM	<ol style="list-style-type: none"> 1. Hang the DCLM or the DIM as the last (right-most) module. <p data-bbox="1117 1283 1523 1409">Note: If both DCLM and DIM are mounted on the same system, the DIM should be the last module.</p> <ol style="list-style-type: none"> 2. Go to main step 5.

4. Hang the AM50/75 axis module on the next mounting fastener.

5. Engage the alignment tab (refer to Figure 2.7).

Figure 2.7
Alignment Tab

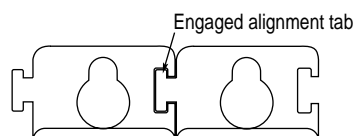

- Slide the slide-and-lock mechanism on the axis module to the left until it locks into place.

Figure 2.8
Slide-and Lock Mechanism

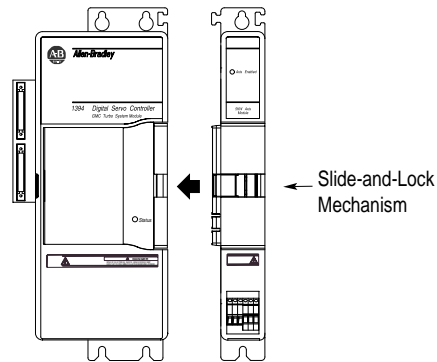

7.

If you:	Do this:
Have more axis modules for this system module	Go to main step 3.
Do not have more axis modules for this system module	Go to main step 8.

- Install the lower fasteners for the system module and all axis modules.
- Attach the terminator to the last axis module. Slide it to the left until it locks in place.

Figure 2.9
Attaching the Terminator

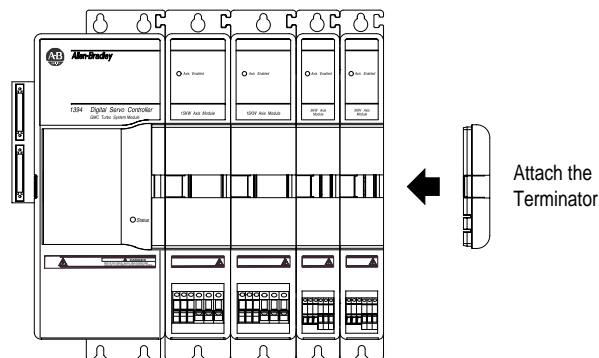

Important: The terminator terminates the serial ring and provides protection for the DC Link. The 1394 system will not operate without the terminator.

- Tighten all mounting fasteners.

Mounting Your 1394-DCLM

Two 1394 system power buses can be linked by connecting two DCLMs together. This procedure is application specific and requires proper implementation. Please contact your Allen-Bradley sales representative for more information.

When using the 1394-DCLM for energy storage, the power plug must be installed (refer to Figure 2.10 for location).

Figure 2.10
Locating the Power Plug

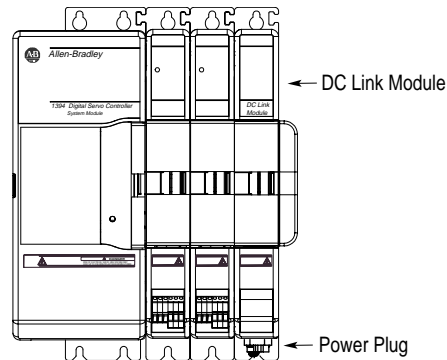

Mounting the External Shunt Resistor for 5 and 10 kW System Modules

If your 5 or 10 kW 1394 system module requires a means of dissipating regenerative energy that exceeds the capacity of the internal shunt resistor, install a 1394 External Shunt Resistor Kit (catalog number 1394-SR10A).



ATTENTION: To avoid the hazard of shock or burn and ignition of flammable material, appropriate guarding must be provided. These resistors can reach temperatures in excess of 350° C (662° F). Install per local codes.

To install the 1394-SR10A Shunt Resistor Kit use two M10 (3/8 in.) bolts and mount the external shunt resistor assembly vertically on a flat rigid metal surface that will not be subjected to shock, vibration, moisture, oil mist, dust or corrosive vapors.

Note: To extend the leadwire length up to 15 m (49 ft total overall length), use MTW, 105° C, (302° F) Class H insulated wire (UL styles 3349, 3374, or equivalent).

Mounting External Shunt Modules for 22 kW System Modules

If you are using a 22 kW system module, you must use a shunt module (1394-SR9A, -SR9AF, -SR36A or -SR36AF). An external shunt module is required for 22 kW system modules because there is no internal shunt resistor.

Shunt Module Mounting Orientation

Because the shunt module dissipates excess regenerative power in the form of heat, you need to consider the following guidelines. Refer to Figure 2.11 and Figure 2.12 for shunt module spacing requirements.

Figure 2.11
Shunt Module Spacing Requirements Within an Enclosure

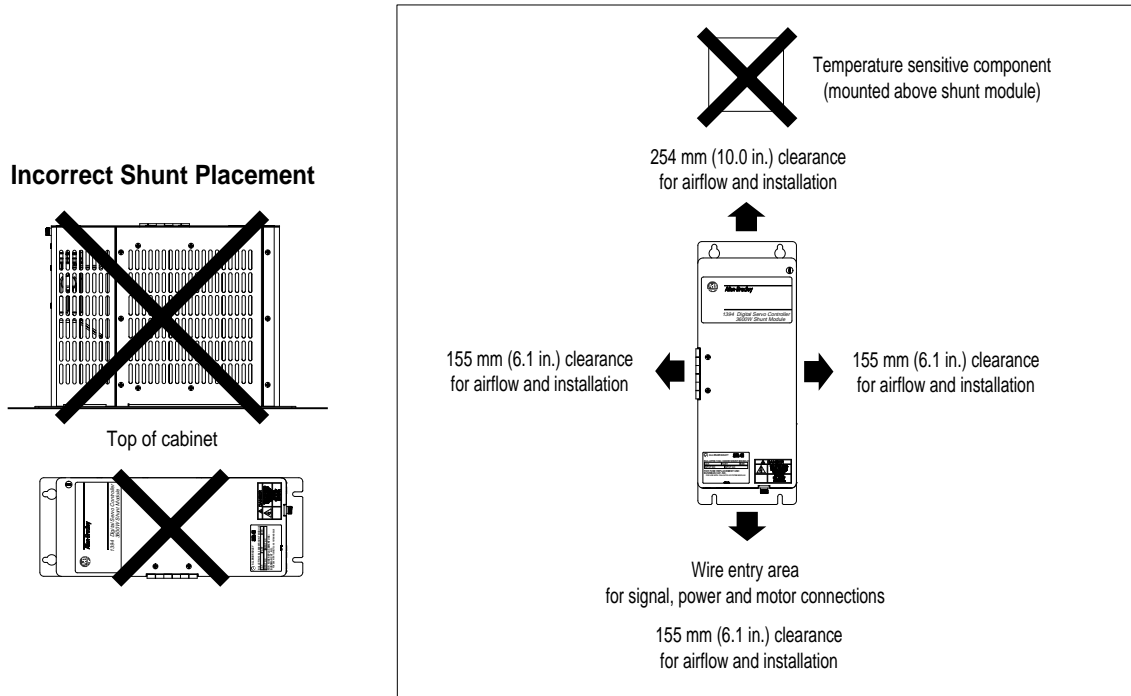
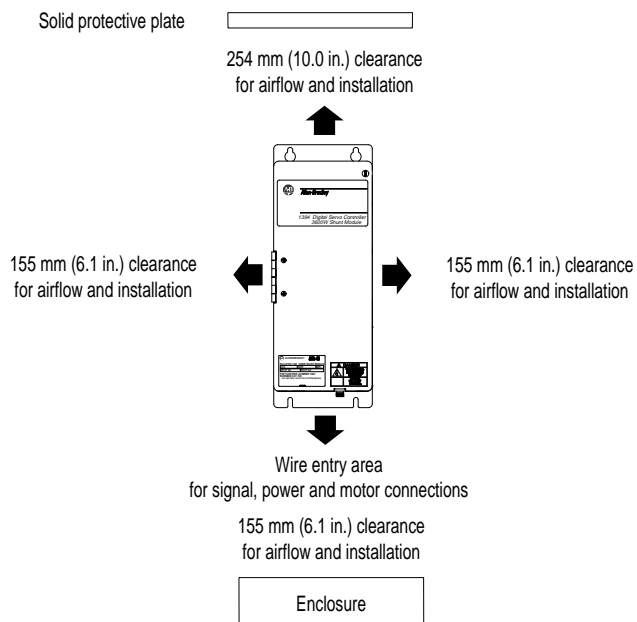

Figure 2.12
Shunt Module Spacing Requirements Outside of an Enclosure



Shunt Module Mounted Outside the Cabinet

The illustration below details the proper position and cable routes for mounting the shunt module outside the cabinet.

Figure 2.13
Shunt Module Mounted Outside of the Cabinet

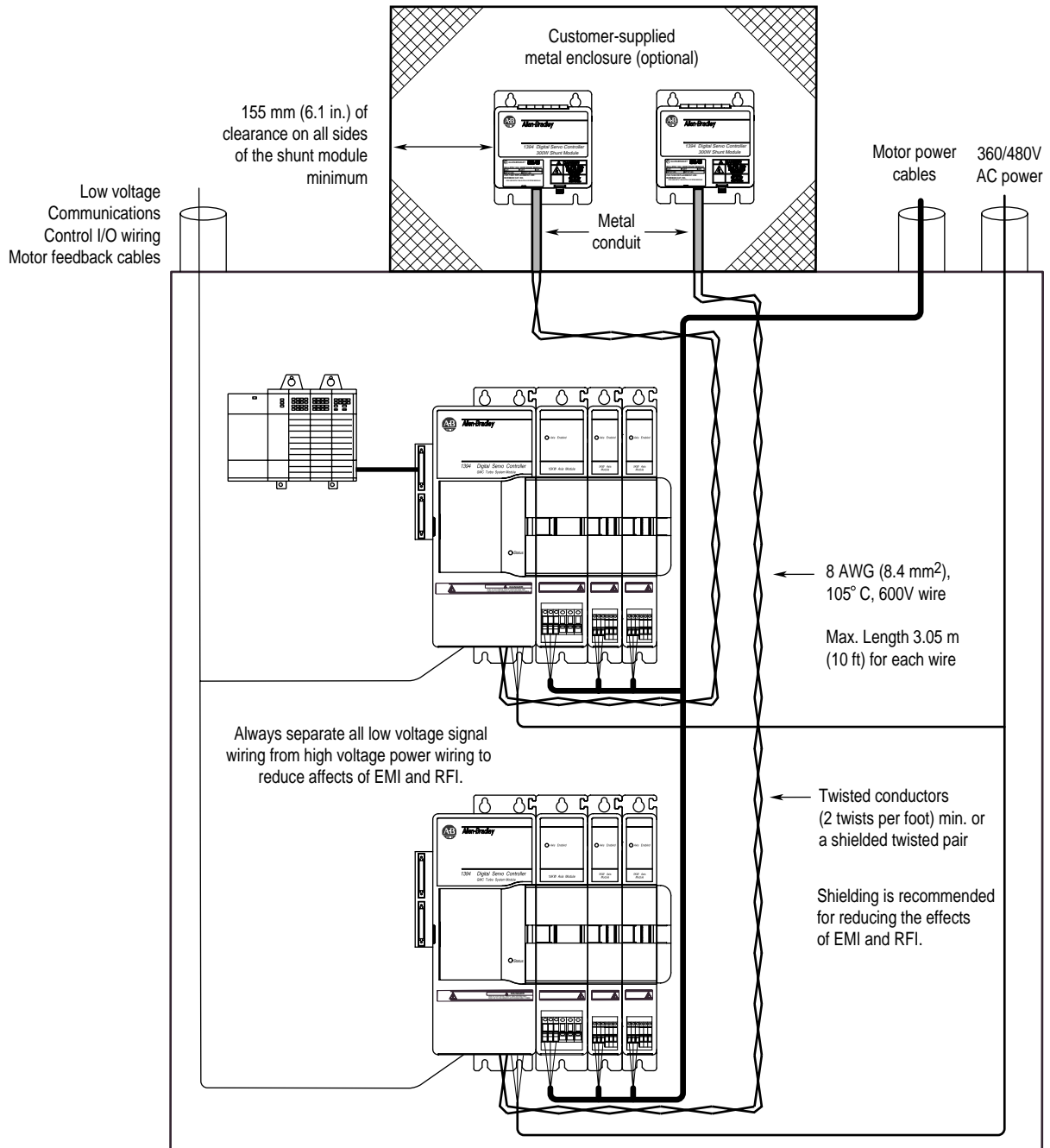

Shunt Module Mounted Inside the Cabinet

The illustration below details the proper position and cable routes for mounting the shunt module inside the cabinet.

Figure 2.14
Shunt Module Mounted Inside of the Cabinet

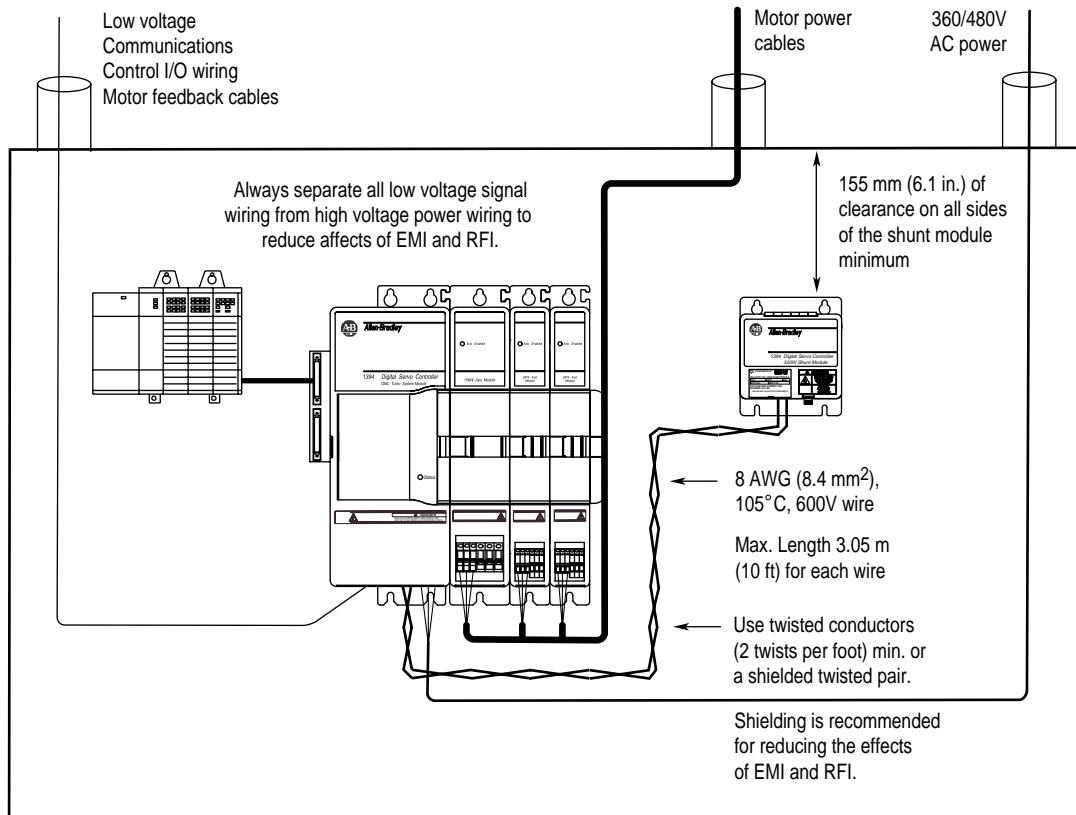

ATTENTION: If you choose to mount the shunt module inside your cabinet, you must make sure that the ambient temperature inside the cabinet does not exceed 50° C (122° F).

Mounting the Shunt Module

The procedures in this section assume you have prepared your panel and understand how to bond your system. To mount your 1394 Shunt Module:

1. Install the top mounting fasteners on the subpanel for the shunt module. The heads of both fasteners should be at least 6.35 mm (0.25 in.) from the panel. Make sure the fasteners are properly bonded to the subpanel. Refer to *Bonding Your System* for more information.
2. Hang the 1394 Shunt Module on the two fasteners.
3. Install the lower fasteners for the shunt module.
4. Tighten all mounting fasteners.

Mounting Considerations for GMC and GMC Turbo Systems

Consider the following when mounting 1394 GMC and GMC Turbo Systems.

Mounting GMC and GMC Turbo Systems Next to Flex I/O™

Separating low voltage communication wiring from high voltage power cables reduces the levels of EMI and RFI. Because high voltage motor wiring is present at the bottom of each axis module we recommend that you mount your Flex I/O modules to the left of the system module.

Figure 2.15
Mounting GMC and GMC Turbo Systems Next to Flex I/O

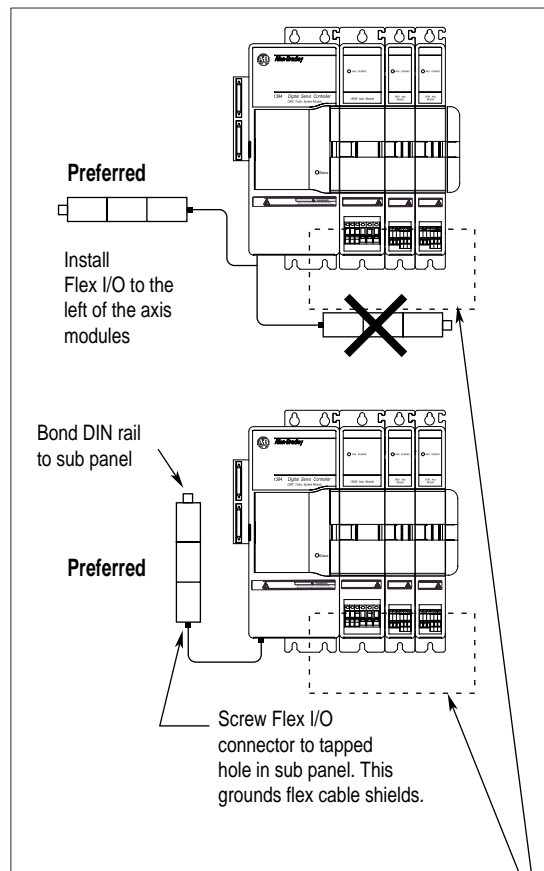

Important: You must separate low voltage I/O from all exposed high voltage conductors to avoid the affects of EMI and RFI.

Wiring System, Axis, and Shunt Modules, and Motors (for all systems)

Chapter Objectives

This chapter covers the following topics:

- Understanding basic wiring requirements
- Determining your type of input power
- Grounding your 1394 system
- Connecting system module power
- Connecting motor power to axis modules
- Connecting feedback to system modules
- Connecting your motor cables to motors
- Connecting your external shunt resistor
- Connecting your shunt module (required for 22 kW system)

Finding Additional Wiring Information for 1394 Systems

The information and procedures included in this chapter apply to the following 1394 systems; GMC Turbo, GMC, 9/440 CNC, CNC Interface, and Analog Servo.

For additional wiring information on:	Refer to the following:
GMC or GMC Turbo system modules	<i>Chapter 4 (Wiring 1394 GMC and GMCTurbo Systems)</i> in this manual.
1394 Analog Servo system modules	<i>Chapter 5 (Wiring Your 1394 Analog Servo System)</i> in this manual.
CNC Interface or 9/440 system modules	<i>9/Series CNC Hardware Integration and Maintenance Manual</i> (publication 8520-6.2).
1394 SERCOS system modules	<i>1394 SERCOS Multi-Axis Motion Control System User Manual</i> (publication 1394-5.20)

Understanding Basic Wiring Requirements

This section contains basic wiring information for the 1394.



ATTENTION: Plan the installation of your system so that you can perform all cutting, drilling, tapping, and welding with the system removed from the enclosure. Because the system is of the open type construction, be careful to keep any metal debris from falling into it. Metal debris or other foreign matter can become lodged in the circuitry, which can result in damage to components.

Important: This section contains common PWM servo system wiring configurations, size, and practices that can be used in a majority of applications. National Electrical Code, local electrical codes, special operating temperatures, duty cycles, or system configurations take precedence over the values and methods provided.

Routing High and Low Voltage Cables

Be aware that when you connect and route power and signal wiring on a machine or system, radiated noise from nearby relays (relay coils should have surge suppressors), transformers, and other electronic drives can be induced into motor or encoder feedback, communications, or other sensitive, low voltage signals. This can cause system faults and communication problems. To minimize the levels of radiated noise, route machine power and signal lines separately.

Figure 3.1
Routing Cables Inside Your Cabinet

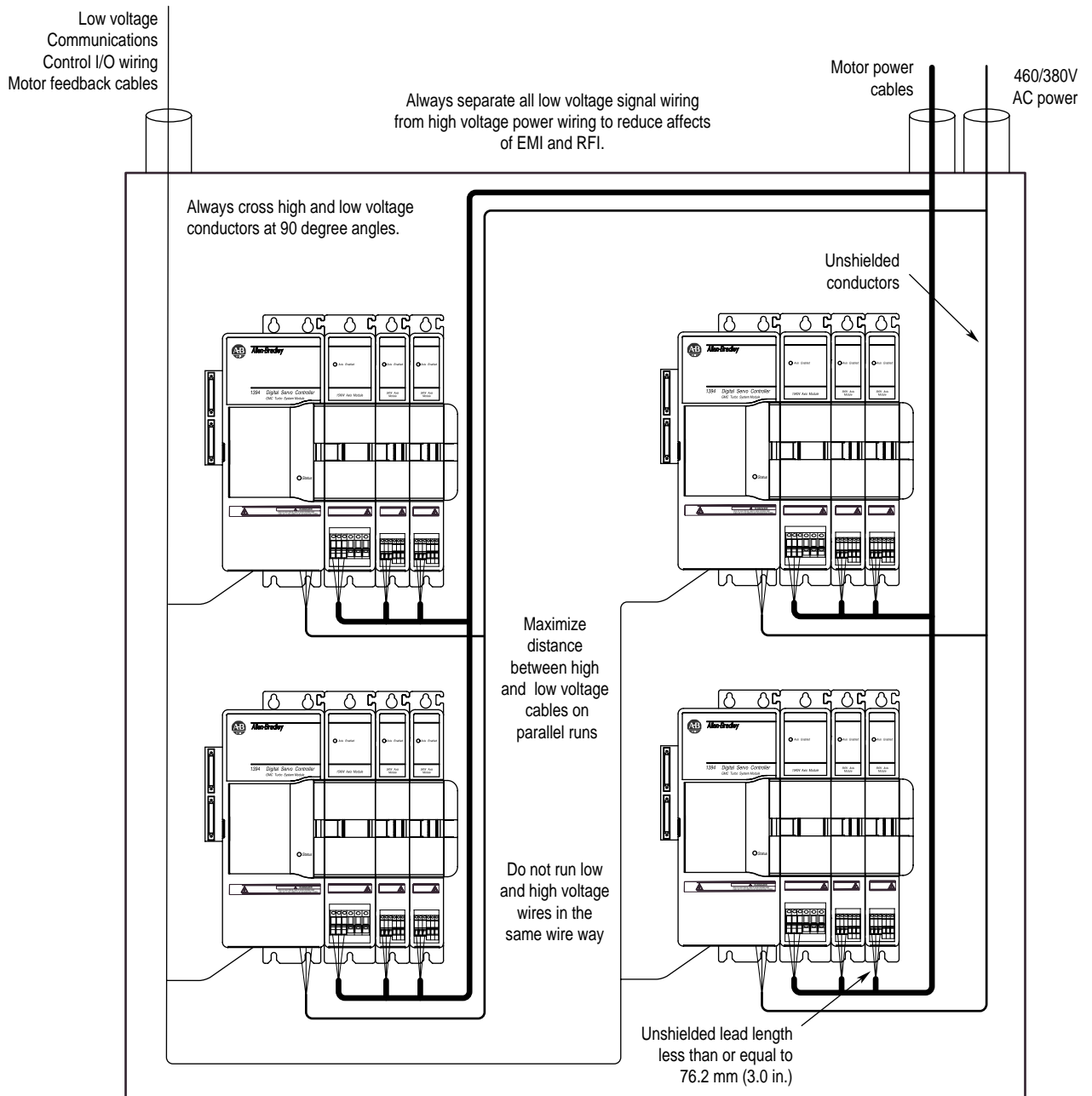

System Module Wire Sizes

All wire sizes in this manual are recommended minimums. Assume that wires are type MTW copper wire (machine tool wire, 75° C, minimum) per NFPA 79 unless otherwise noted. Consult the National (or local) Electrical Code for factors related to ambient conditions, length, etc. See your Allen-Bradley Sales Representative for more information.

Shielding

To minimize radiated and induced noise problems or ground loops, separate feedback, command, and other shields from each other and connect them at a common machine or system earth ground. Connect all shields to a single earth ground point. Refer to *Grounding Your 1394 System* in this chapter and *Appendix B* for additional information.

Insulate the open-ended shields (resolver feedback cable at the resolver and velocity command cable at the servo drive) so that they do not cause ground loops.

EMI/RFI Shielding

The 1394 has an inverter carrier frequency of 5000 Hz. The drive's output inverter switching sequence produces a carrier frequency of 10,000 Hz when measured at the motor. This can induce noise into sensitive equipment lines adjacent to it.



ATTENTION: This system can produce electromagnetic radiation that can cause industrial or radio-controlled equipment to operate erratically and cause possible injury to personnel. The 1394 system is designed to be interconnected with Allen-Bradley EMI shielded motor cables only. Do not substitute cables. The EMI shield of the motor power cable must be grounded at both ends to function properly.

EMI/RFI Bonding

The metal chassis of electrical components should be bonded to the subpanel in an electrical cabinet with metal to metal contact. The purpose of a high frequency (HF) bond is to provide HF noise currents a path of least impedance to return to their source.

Input Power Conditioning

You can directly connect the 1394 to a three-phase, AC power line. However, if certain power line conditions exist, the input power component can malfunction. If either of the following is true, you can use a line reactor or isolation-type transformer to reduce the possibility of this type of malfunction:

- The AC line supplying the drive has power factor correction capacitors.
- The AC line frequently experiences transient power interruptions or significant voltage spikes.

Important: Line conditioning is not typically required. If you have experienced power problems in the past on a power distribution line, you may need to consider input power conditioning.



ATTENTION: The 1394 does not supply line fuses or a circuit breaker. They are customer-supplied items. Branch circuit breakers or disconnect switches cannot provide the level of protection required by drive components. Refer to *Appendix A* for size and type recommendations.

Determining Your Type of Input Power

Before you ground or wire your 1394 system you must determine the type of 360/480V input power you will be connecting to. The 1394 system is designed to operate in both grounded and ungrounded environments.

Grounded Power Configuration

As shown in the figure below, the grounded power configuration allows you to ground your 3-phase power at a neutral point. Each 1394 system module has a factory-installed jumper configured for grounded power distribution. If you determine that you have grounded power distribution in your plant you do not need to modify your system.

Figure 3.2
Grounded Power Configuration

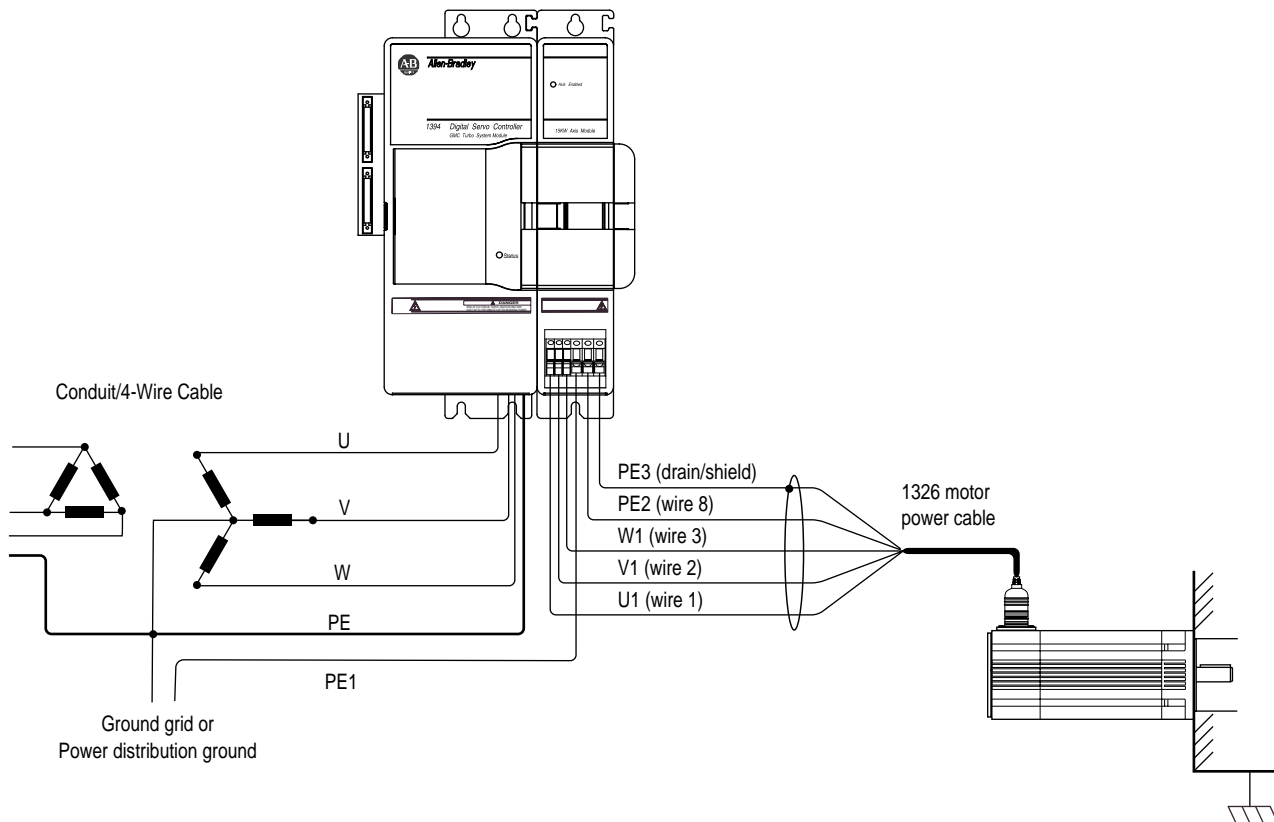

Ungrounded Power Configuration

As shown in the figure below, the ungrounded power configuration does not allow for a neutral ground point. If you determine that you have ungrounded power distribution in your plant, you need to move the factory-installed jumper to the ungrounded power distribution position to prevent electrostatic buildup inside the 1394. Refer to the ground jumper procedures for the system module you need to configure.

Figure 3.3
Ungrounded Power Configuration

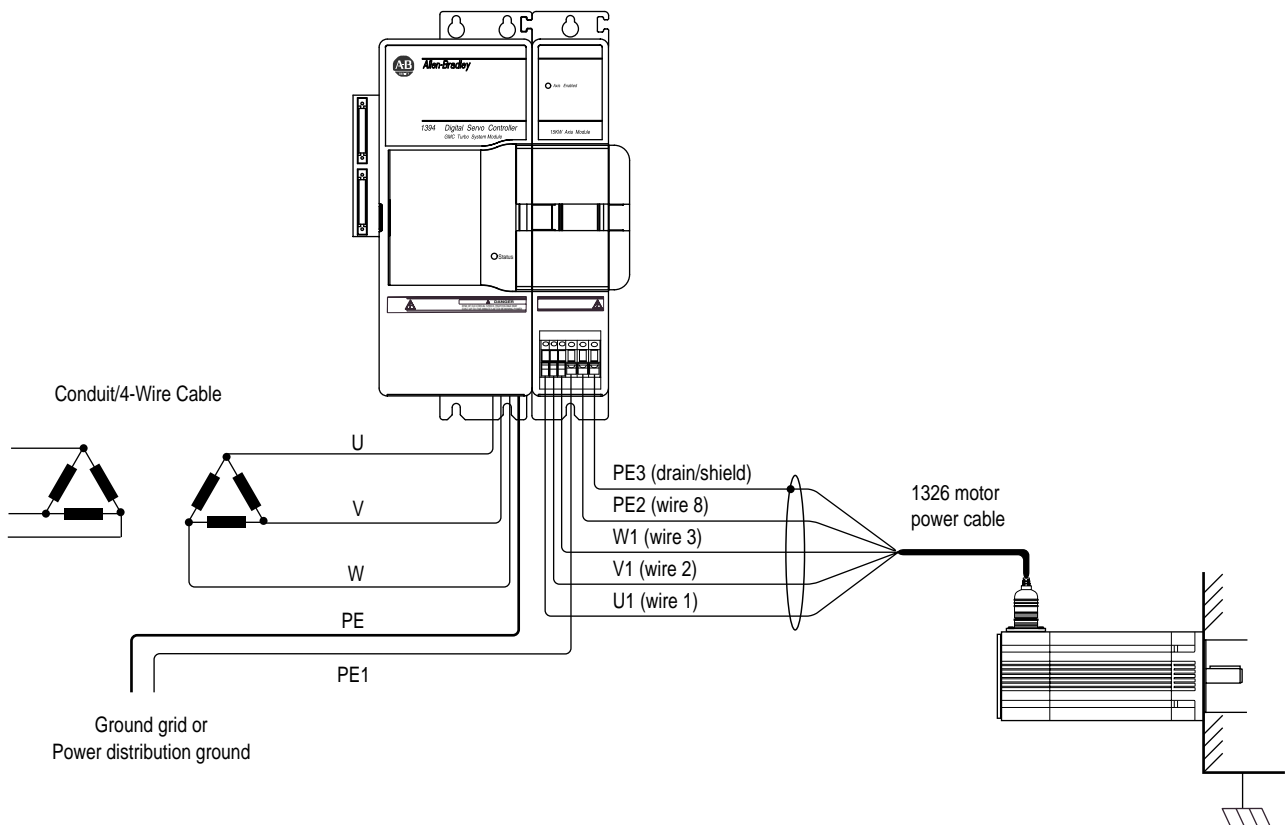

ATTENTION: Ungrounded systems do not reference each phase potential to a power distribution ground. This can result in an unknown potential to earth ground.

Setting the Ground Jumper in a 5 or 10 kW System Module for Ungrounded Power Configurations

This procedure assumes that you have bonded and mounted your 1394x-SJT05-x or 1394x-SJT10-x system module to the subpanel and that there is no power applied to the system. To set the ground jumper for an ungrounded system:

Important: If you have grounded power distribution, you do not need to set the ground jumper. Go to *Grounding Your 1394 System*.

1. Verify that all 24V control and 360/480V power has been removed from the system.
2. Open the system module door.
- 3.

For ground jumper settings on this system module:	Do this:
Series A and B	<ol style="list-style-type: none"> 1. Locate the jumper connected to J26 and J27 on the circuit board behind the Danger label in the upper right hand corner of the system module (refer to Figure 3.4 for the jumper's location). 2. Unplug the jumper from J26. 3. Plug the jumper in GND3. 4. Go to main step 4.
Series C	<ol style="list-style-type: none"> 1. Unplug the ribbon cable from the input wiring board (refer to Figure 3.4 for location). 2. Remove the three control board screws. 3. Remove the control board (pull it straight out from system module). 4. Locate the jumper connecting J4 and J5, and move one end of the jumper from J5 to J6. 5. Re-install the control board. Align the guide pins in the rear of the enclosure with holes in the control board. 6. Re-install the three control board screws and re-connect the ribbon cable. 7. Go to main step 4.

Note: To determine the series of your module, refer to Figure P.1 in the *Preface*.

4. Close the system module door.
5. Go to *Grounding Your 1394 System*.

Figure 3.4
Ground Jumper Locations for the 5 and 10 kW System Modules

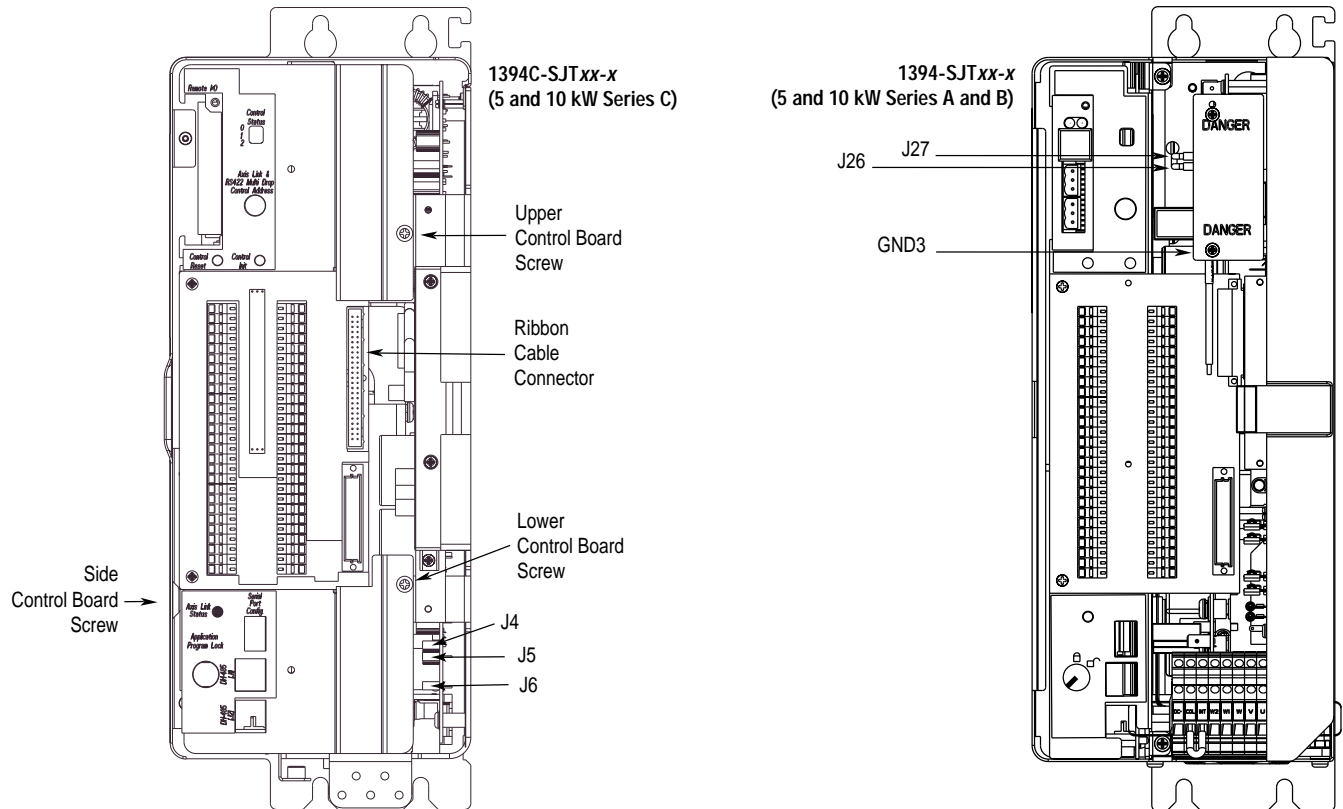

Setting the Ground Jumper in a 22 kW System Module for Ungrounded Power Configurations

This procedure assumes that you have bonded and mounted your 1394x-SJT22-x system module to the subpanel and that there is no power applied to the system. To set the ground jumper:

Important: If you have grounded power distribution, you do not need to set the ground jumper. Go to *Grounding Your 1394 System*.

1. Verify that all 24V control and 360/480V power has been removed from the system.
2. Open the system module door.
3. Disconnect both ends of the input wiring board ribbon cable. Refer to Figure 3.5 for the location of the ribbon cable.
4. Remove the upper and lower input wiring board screws. Refer to Figure 3.5 for the location of the screws.
5. Remove the input wiring board.

Figure 3.5
Removing the Input Wiring Board in a 22 kW System Module

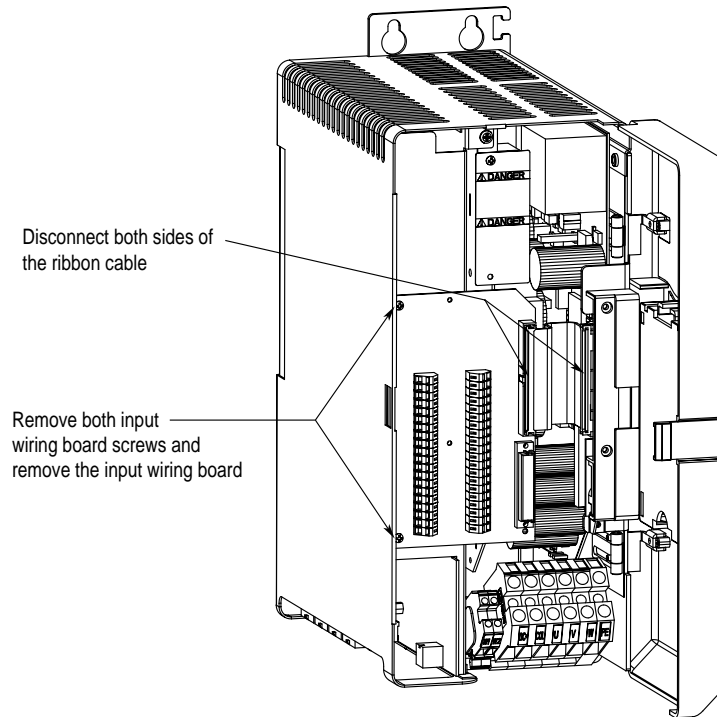

6. Locate the ground jumper inside the system module. Refer to the figure below for jumper location.

Figure 3.6
Location of the 22 kW System Module Ground Jumper

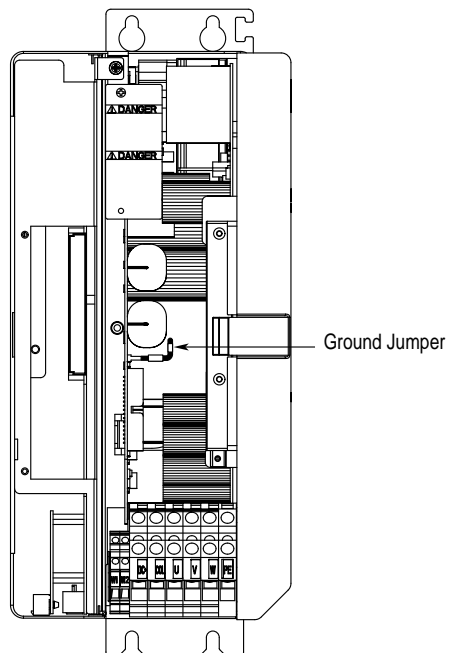

7. Without removing the circuit board, unplug the jumper and move it to the ungrounded power distribution position. Refer to the figure below for the jumper positions.

Figure 3.7
22 kW System Module Jumper Positions

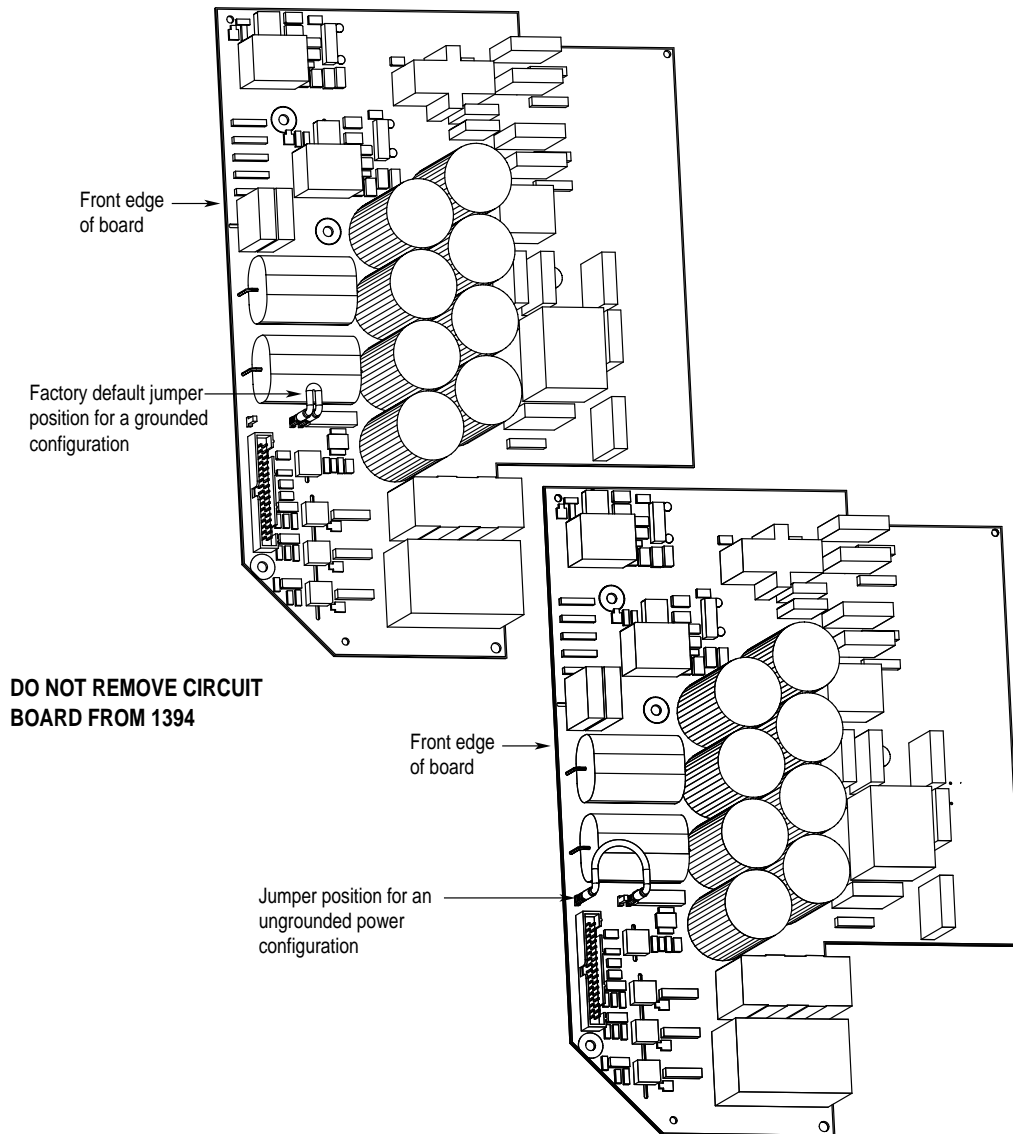

8. Re-install the input wiring board.
9. Re-install the upper and lower input wiring board screws. Refer to Figure 3.5 for the location of the screws.
10. Re-connect both ends of the input wiring board ribbon cable. Refer to Figure 3.5 for the location of the ribbon cable.
11. Close the system module door.
12. Go to *Grounding Your 1394 System*.

Grounding Your 1394 System

We recommend that all equipment and components of a machine or process system have a common earth ground point connected to their chassis. A grounded system provides a safety ground path for short circuit protection. Grounding your modules and panels minimizes shock hazards to personnel and damage to equipment caused by short circuits, transient overvoltages, and accidental connection of energized conductors to the equipment chassis.

Grounding your System to the Subpanel

The National Electrical Code contains grounding requirements, conventions, and definitions. Follow all applicable local codes and regulations to safely ground your system. Refer to the illustration below for details on grounding your system and axis modules. Refer to *Appendix B* for interconnect information.

Figure 3.8
PE Safety Ground Configuration with Multiple 1394 Systems on One Panel

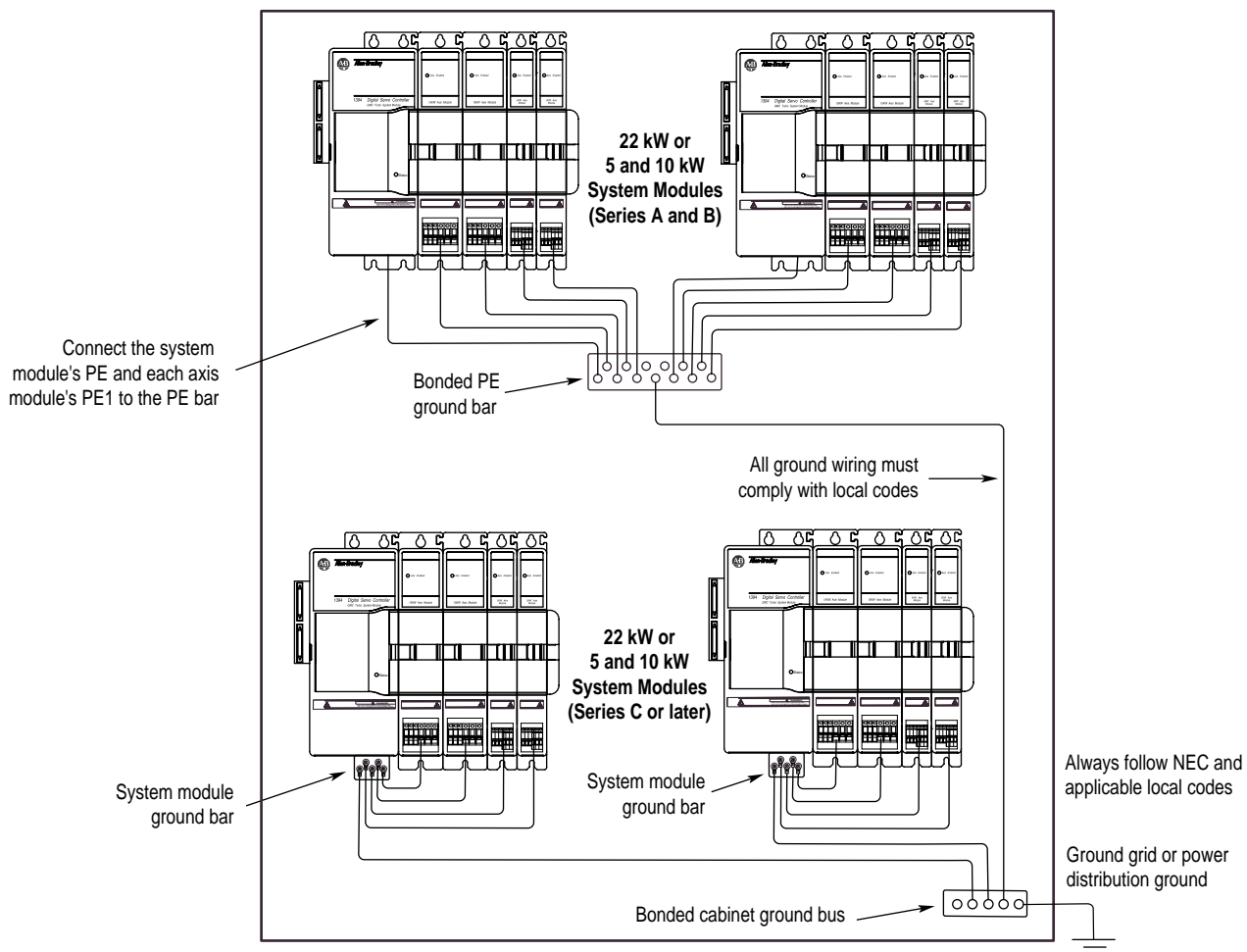

Grounding Multiple Subpanels

To ground multiple subpanels, refer to the figure below.

Figure 3.9
Subpanels Connected to a Single Ground Point

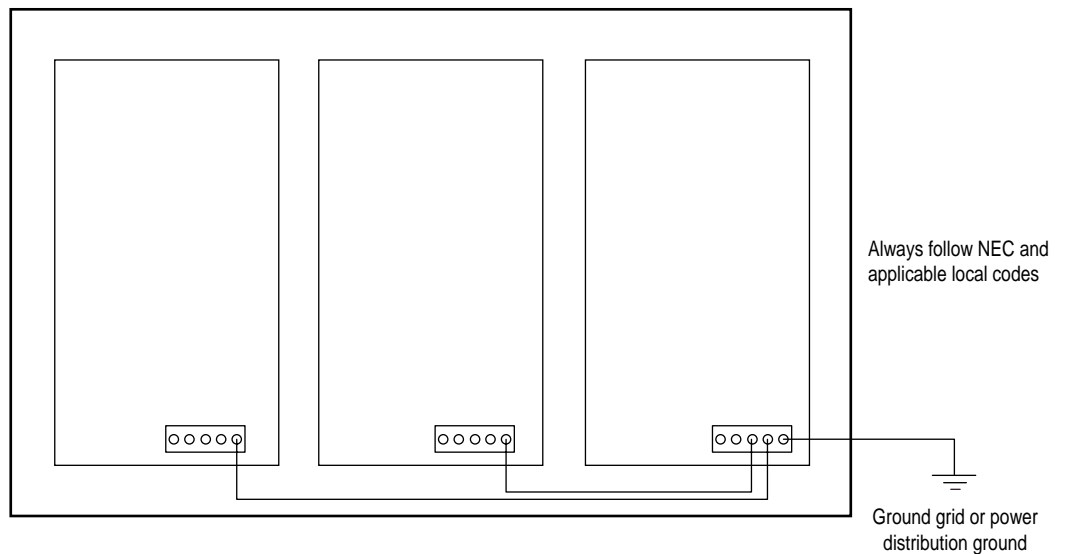

Wiring System Module Power

The system module provides terminating points for the AC power input, logic power, feedback, and various other control signals. The slide-and-lock mechanism transfers power and commutation signals to each axis module.

Each individual application requires different wiring. This section provides guidelines for wiring your system. Because of the diversity of applications and systems, no single method of wiring is applicable in all cases.

Terminal Block Locations for 5 and 10 kW System Module (Series A and B)

The 5 and 10 kW system module (Series A and B) components use IEC terminals for power connections. You will wire the system and axis modules using the power terminal block conveniently located at the bottom front of the system and axis modules. The maximum wire size allowed in the terminal blocks is 3.3 mm² (12 AWG). To gain access to the input power terminals, open the system module door and look in the lower right corner. Refer to Figure 3.10 for terminal block details.



ATTENTION: To avoid personal injury and/or equipment damage ensure installation complies with specifications regarding wire types, conductor sizes, branch circuit protection, and disconnect devices. The National Electrical Code (NEC) and local codes outline provisions for safely installing electrical equipment.

Figure 3.10
Terminal Block for a 5 or 10 kW System Module (Series A and B)

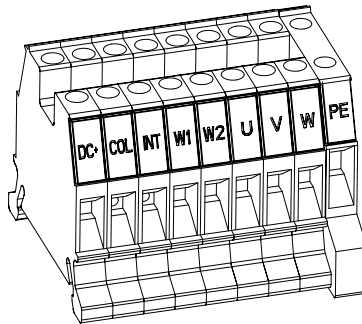

Wire:	Description:	Connects to terminal(s):	Required (Y/N):
24V Logic	A user-supplied 24V AC rms or 24V DC power source. Refer to <i>Appendix A</i> for 24V input power specifications.	W1 and W2	Y
360/480V AC Input Power	360/480V AC, three-phase power input Refer to <i>Appendix A</i> for system specifications for rated AC input voltage, tolerance, and source impedance.	U, V, and W	Y
Input Power Neutral	Three-phase input neutral (present only on grounded power configurations).	System ground bar	N
PE Ground	The 1394's ground connection to the bonded system ground bar on the subpanel.	PE	Y
External Shunt Resistor	Optional 1400W external shunt resistor used to dissipate excess regenerative energy from the system module.	DC+ and COL	N

Note: Refer to *Appendices A* and *B* for information about three-phase input fusing and circuit breaker information as related to the power input. Refer to the section *Connecting Your External Shunt Resistor* for information about wiring the optional shunt resistor to the 5 and 10 kW system modules.

Connector Locations for 5 and 10 kW System Module (Series C)

The 5 and 10 kW system module (Series C) uses connectors instead of IEC terminals for connecting power. You will wire the system using power connectors (J1, J10, and J11) that mate with plugs (P1, P10, and P11) conveniently located on the bottom of the system module. Figure 3.11 details the location of the connectors.



ATTENTION: To avoid personal injury and/or equipment damage ensure installation complies with specifications regarding wire types, conductor sizes, branch circuit protection, and disconnect devices. The National Electrical Code (NEC) and local codes outline provisions for safely installing electrical equipment.

Figure 3.11
Connectors for 5 and 10 kW System Module (Series C)

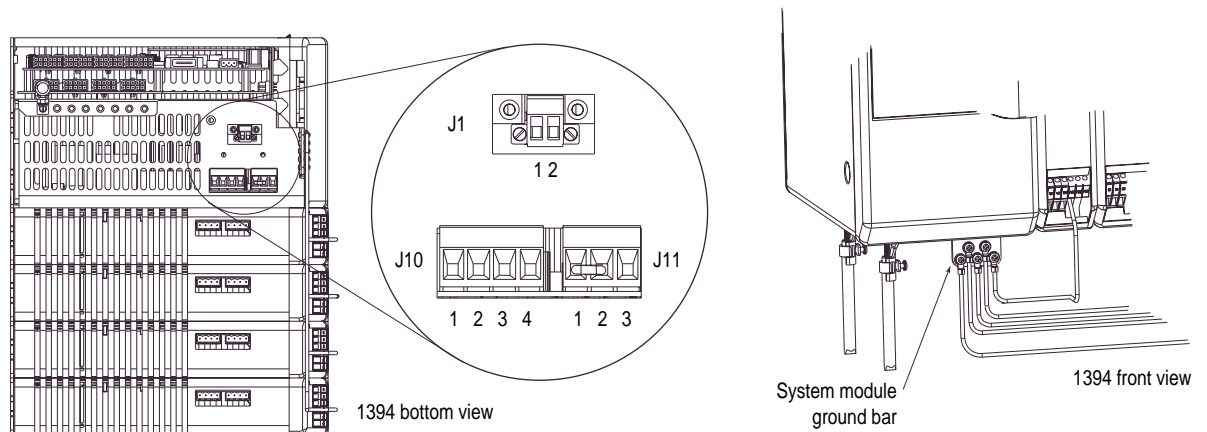

Wire:	Description:	Maximum wire size:	Connects to terminal(s):	Required (Y/N):
24V Logic	A user-supplied 24V AC rms or 24V DC power source. Refer to <i>Appendix A</i> for 24V input power specifications.	3.3 mm ² (12 AWG)	J1-1 and J1-2	Y
360/480V AC Input Power	360/480V AC, three-phase power input Refer to <i>Appendix A</i> for system specifications for rated AC input voltage, tolerance, and source impedance.	5.3 mm ² (10 AWG)	J10-1 (U) J10-2 (V) and J10-3 (W)	Y
Input Power Neutral	Three-phase input neutral (present only on grounded power configurations).	5.3 mm ² (10 AWG)	J10-4	N
PE Ground	The 1394's ground connection to the bonded system ground bar on the subpanel.	8.4 mm ² (8 AWG)	System module ground bar	Y
External Shunt Resistor	Optional 1400W external shunt resistor used to dissipate excess regenerative energy from the system module.	5.3 mm ² (10 AWG)	J11-3 and J11-1	N

Note: Refer to *Appendices A* and *B* for information about three-phase input fusing and circuit breaker information as related to the power input. Refer to the section *Connecting Your External Shunt Resistor* for information about wiring the optional shunt resistor to the 5 and 10 kW system modules.

Terminal Block Locations for a 22 kW System Module

All 22 kW system module components use IEC terminals for power connections. You will wire the system and axis modules using the power terminal block conveniently located at the bottom front of the system and axis modules. To gain access to the input power terminals, open the system module door and look in the lower right corner. Figure 3.12 details the order of the terminal blocks.



ATTENTION: To avoid personal injury and/or equipment damage, ensure installation complies with specifications regarding wire types, conductor sizes, branch circuit protection, and disconnect devices. The National Electrical Code (NEC) and local codes outline provisions for safely installing electrical equipment.

Figure 3.12
Terminal Block for 22 kW System Module

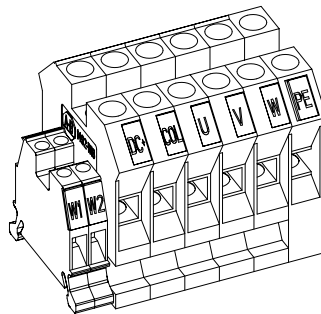

Wire:	Description:	Maximum wire size:	Connects to terminal(s):	Required (Y/N):
24V Logic	A user-supplied 24V AC rms or 24V DC power source. Refer to <i>Appendix A</i> for 24V input power specifications.	3.3 mm ² (12 AWG)	W1 and W2	Y
360/480V AC power input	360/480V AC, three-phase power input. Refer to <i>Appendix A</i> for system specifications for rated AC input voltage, tolerance, and source impedance.	8.4 mm ² (8 AWG)	U, V, and W	Y
Input Power Neutral	Three-phase input neutral (present only on grounded power configurations).	8.4 mm ² (8 AWG)	System ground bar (Series A and B)	N
			PE (Series C)	N
PE Ground	The 1394's ground connection to the bonded system ground bar on the subpanel.	8.4 mm ² (8 AWG)	PE (Series A and B)	Y
			System module ground bar (Series C)	Y
External Shunt Module	Used to dissipate excess regenerative energy from the system module.	8.4 mm ² (8 AWG)	DC+ and COL	Y

Note: Refer to *Appendices A* and *B* for information about three-phase input fusing and circuit breaker information as related to the power input. Refer to the section *Connecting Your Shunt Module* for information about wiring the shunt module to the 22 kW system module.

Required Tools and Equipment

Before you begin to connect power wiring, be sure to have the following:

- A small, flathead screwdriver
- User-supplied contactor
- User-supplied wiring for input power

Connecting Power Wiring for 5 and 10 kW (Series A and B) and 22 kW System Modules

To connect power wiring:

1. Connect the ground wire for the system module to the bonded ground bus bar on the subpanel. For more information on bonding, refer to the chapter *Installing Your 1394*.
2. Open the front door of the system module.
3. Connect the system ground bar wire as follows:

If your system module is:	Then:
5 and 10 kW or 22 kW (Series A and B)	Insert the system ground bar wire in the terminal block labeled PE.
22 kW (Series C)	Connect the system ground bar wire to the system module ground bar.

4. Connect the three-phase incoming power wires as follows:

Insert the wire labeled:	Into this terminal block:
U	U
V	V
W	W

5. Connect the three-phase input neutral wire as follows:

If your system module is:	Then:
5 and 10 kW or 22 kW (Series A and B)	Connect the three-phase input neutral wire to the bonded system ground bar. For more information on bonding, refer to the chapter <i>Installing Your 1394</i> .
22 kW (Series C)	Insert the three-phase input neutral wire in the terminal block labeled PE.

Note: The three-phase input neutral connection is present only on grounded power configurations.

6. Insert one of the 24V control power wires into the terminal block labeled W1.
7. Insert the other 24V control power wire into the terminal block labeled W2.
8. Tighten and torque all six screw terminals to the values in the following table.

System Module:	Terminal Block Designator:	Terminal Block Torque:
5 and 10 kW	All	0.56 - 0.62 N-m (5.0 - 5.6 lb-in.)
22 kW	W1, W2	0.56 - 0.62 N-m (5.0 - 5.6 lb-in.)
	DC+, COL, U, V, W, PE	2.21 - 2.66 N-m (20.0 - 24.0 lb-in.)

9. Gently pull on each wire to make sure it does not come out of its terminal. Re-insert and tighten any loose wires.
10. Go to the section *Connecting Motor Power to Axis Modules*.

Connecting Power Wiring for 5 and 10 kW System Modules (Series C)

To connect power wiring:

1. Connect the system module ground wire from the system module ground bar to the bonded ground bus bar on the subpanel. For more information on bonding, refer to the chapter *Installing Your 1394*.
2. Insert the three-phase input neutral wire into connector terminal J10-4 and tighten the J10-4 connector screw (torque value = 0.56-0.62 N-m, 5.0-5.6 lb-in.).

Note: The three-phase input neutral connection is present only on grounded power configurations.

3. Insert the three-phase incoming power wires as follows and tighten the three J10 connector screws.

Insert the wire labeled:	Into connector terminal:	Tighten to this torque value:
U	J10-1	0.56-0.62 N-m (5.0-5.6 lb-in.)
V	J10-2	
W	J10-3	

4. Gently pull on each wire to make sure it does not come out of its terminal. Re-insert and tighten any loose wires.

5. Plug J10 into P10.
6. Insert one of the 24V control power wires into connector terminal J1-1 and tighten the J1-1 connector screw (torque value = 0.56-0.62 N-m, 5.0-5.6 lb-in.).
7. Insert the other 24V control power wire into connector terminal J1-2 and tighten the J1-2 connector screw (torque value = 0.56-0.62 N-m, 5.0-5.6 lb-in.).
8. Gently pull on each wire to make sure it does not come out of its terminal. Re-insert and tighten any loose wires.
9. Plug J1 into P1.
10. Gently pull on each wire to make sure it does not come out of its terminal. Re-insert and tighten any loose wires.
11. Go to *Connecting Motor Power to Axis Modules*.

Connecting Motor Power to Axis Modules

The procedures in this section detail how to connect motor cable flying leads to the terminals on the front of each axis module. You must use one 1326-CPx1-xxx motor power cable for each of your 1326Ax servo motors. Refer to the interconnect drawings in *Appendix B* for more information. The table below describes each of the terminals.

Terminal:	Description:
U1	Motor Power A
V1	Motor Power B
W1	Motor Power C
PE1	Axis Ground
PE2	Motor Ground
PE3	Overall Shield

Connecting Thermal and Brake Leads to Axis Modules

Axis modules provide terminating points for the motor power, thermal sensor, and brake. Axis module wiring is identical for all available axis module ratings.

Figure 3.13
Locating TB1 and TB2

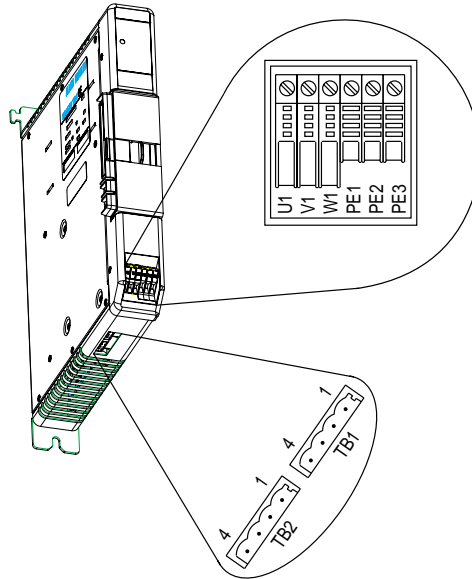

Important: Noise filters on the motor thermal sensor and brake connectors (TB1 and TB2) add capacitance (1.0 μF) from each leg of the thermal switch and motor brake leads to ground. This should be considered when selecting ground fault circuits.

Connect the motor thermal sensor and brake lead to the Axis Module at TB1 and TB2. Each axis module comes with a brake and thermal connector kit. Refer to *Appendix D* for more information.

Terminal:	Description:
TB1-1, 2	Thermal Sensor Input from Motor Cable
TB1-3, 4	Brake 24V DC from Motor Cable
TB2-1, 2	Brake 24V DC from Fault System
TB2-3, 4	Thermal Sensor Output to Fault System

Required Tools and Equipment

- A small, flathead screwdriver
- One 1326-CPx1-xxx motor power cable for each axis
- One axis module connector kit (catalog number 1394-199) for thermal switch and brake inputs. You will need one kit per axis module as each kit contains two connectors.

Wiring Motor Power, Thermals and Brakes

The procedures in this section assume that your system and axis modules are already mounted. We recommend that you start at either the first or last axis module, wire it completely, and then wire the module next to it completely, and so on until they are all wired.

To wire your 1394 axis modules:

1.

If your system module is:	Then do this:
Series A or B	<ol style="list-style-type: none"> 1. Bond one end of the axis module ground wire to the subpanel. 2. Connect the other end of the ground wire to terminal block PE1. 3. Go to main step 7.
Series C	<ol style="list-style-type: none"> 1. Connect one end of the axis module ground wire to the system module ground bar. 2. Connect the other end of the ground wire to terminal block PE1. 3. Go to main step 2. Refer to Figure 3.14 for main steps 2-6.

Note: For more information on bonding, refer to the chapter *Installing Your 1394*.

Important: To improve the bond between the motor cable shield and the axis module PE ground, a cable shield clamp is included with the Series C axis modules.

Figure 3.14
Series C Axis Module Cable Clamp

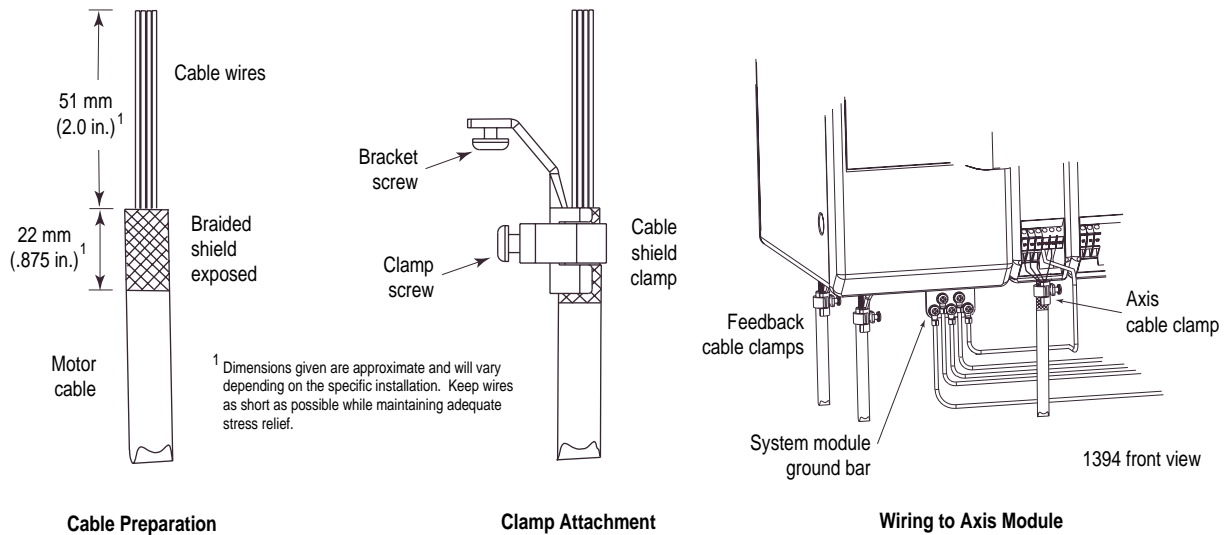

2. Prepare one end of the motor cable for attachment to the cable shield clamp by removing the outer insulation and braided shield from the motor cable. Ensure approximately 51 mm (2.0 in.) of the insulated cable wires are exposed (refer to Figure 3.14).
3. Remove another 22 mm (.875 in.) of insulation to expose the braided shield underneath for clamp attachment.

Important: When cutting into the insulation use care not to cut into the braided shield underneath.

4. Position the cable shield clamp over the exposed braided shield (ensure clamp screw is behind clamp and not braided shield).
5. Tighten the clamp screw.

Important: Do not overtighten the clamp screw or damage to the braided shield may result.

6. Thread the bracket screw into the bottom of the axis module and tighten.
7. Connect an axis module connector kit (catalog number 1394-199) to each motor cable that you will use. Refer to instructions that come with the kit for the specific connections.

8. On one axis, connect the wires as follows:

Insert the wire labeled:	Into this terminal block:
1	U1
2	V1
3	W1
8	PE2
bare wire (no label)	PE3 (Series A and B modules)
	N/A (Series C) The bare wire is replaced by the cable shield clamp on the motor cable.

9. Tighten and torque all five screw terminals to the values in the following table.

Axis Module:	Terminal Block Designator:	Terminal Block Torque:
2 kW, 3 kW, 5 kW	All	0.56 - 0.62 N-m (5.0 - 5.6 lb-in.)
10 kW, 15 kW	All	1.55 - 2.0 N-m (14.0 - 18.0 lb-in.)

10. Gently pull on each wire to make sure it does not come out of its terminal. Re-insert and tighten each loose wire.
11. Connect the brake and thermal switch connector to the front-most mating half (TB1) under its axis module. Refer to Figure 3.13 for location of TB1. Refer to *Appendix B* for thermal switch interconnect information.
- 12.

If your motor:	Do the following:
Has the brake option	<ol style="list-style-type: none"> 1. Connect the appropriate control wires to the second connector in the axis module connector kit to the appropriate cable. 2. Insert the connector in the rear-most mating half (TB2) for its axis. 3. Go to main step 13.
Does not have the brake option	Go to main step 13.

13. Wire your thermal switch into the appropriate control circuitry for monitoring purposes. Refer to *Appendix B* for thermal switch interconnect information.



ATTENTION: To avoid damage to your motor, monitor the thermal switch for overheat conditions.

14.

If you:	Do this:
Have more axis modules to wire	1. Move to the next axis module. 2. Go to the main step 2.
Have wired all of your axis modules	Go to <i>Connecting Feedback to System Modules</i> .

Connecting Feedback to System Modules

The procedure in this section assumes that your system and axis modules are already mounted and your power is wired. Wire the commutation resolver (integral to the 1326 motor) to the system at the connectors shown in the following table. You must use Allen-Bradley 1326-CCU-xxx shielded cables for proper operation. Refer to *Appendix D* for more information on connectors and accessories.



ATTENTION: To guard against hazard of personal injury or damage to equipment, the interconnections between the motor and resolver must be made exactly as shown in *Appendix B*. Failure to do so could cause loss of motor control and/or severe oscillation of the motor shaft.

Note: All CCU cables are shipped with pre-pinned connections and loose connector housings for the system end.

If you are using this system module:	Connect it to terminal(s):	M, O, or N/A:
GMC Turbo or GMC	J5 (axis 0), J6 (axis 1), J7 (axis 2), and J10 (axis 3). Refer to <i>Wiring 1394 GMC and GMC Turbo Systems</i> for locations.	M
9/440 CNC or CNC Interface	FB0 (axis 0) through FB3 (axis 3). Refer to the <i>9/Series Integration and Maintenance Manual</i> (publication 8520-6.2) for more information.	M
Analog Servo	FB0 (axis 0), FB1 (axis 1), FB2 (axis 2), and FB3 (axis 3). Refer to <i>Wiring Your 1394 Analog Servo System</i> for locations.	M

M = mandatory, O = optional, and N/A = non applicable

To improve the bond between the motor feedback cable shield and the system module PE ground, a cable shield clamp is included with the Series C system modules.

Ensure an appropriate amount of the cable insulation and braided shield is removed from the feedback cable. Place the cable wires and exposed braided shield into the cable shield clamp and tighten the clamp screw. Then thread the bracket screw into the bottom of the system module and tighten. Refer to Figure 3.14 for an illustration.

The table below provides pin-outs for the resolver connection.

Terminal:	Wire Number:	Color:	Function:
1	1	Black	Axis x R1
2	1	Shield	Shield
3	2	Black	Axis x S1
4	3	Green	Axis x S2
5	3	Shield	Shield
6	1	White	Axis x R2
7	2	Shield	Shield
8	2	Red	Axis x S3
9	3	Black	Axis x S4
10	Overall Shield	Overall Shield	Overall Shield

To connect motor feedback:

1. Connect the connector shells to the resolver feedback cables.
2. For each axis/motor you will use, connect one motor resolver feedback cable to the appropriate feedback connector on the bottom of the system module control board. For the location of those connectors, refer to the drawing on the inside of the system module door or the section *Finding Additional Wiring Information for 1394 Systems*.
- 3.

If you are:	Do this:
Using the AQuadB option (for Analog Servo system only)	<ol style="list-style-type: none"> 1. Connect the connector shells to the 1394-SA15 cables. Refer to the instructions that came with the cables for more information. 2. For each AQuadB output you will use, connect one 1394-SA15 cable to the AQuadB mating slot under the system module. 3. Go to step 4.
Not using the AQuadB option	Go to step 4.

4.

If you have:	Do this:
More motors to wire	1. Move to the next motor. 2. Go to the main step 1.
Wired all of your motors	Go to <i>Connecting Your Motor Cables to Motors</i> .

Connecting Your Motor Cables to Motors

This procedure assumes that your system and axis modules are already mounted and wired. To connect your motor cables:

1. Orient the motor end of the resolver cable so that the flat on the connector is facing the shaft of the motor.
2. Push the cable onto the appropriate mating half until it clicks.
3. Orient the motor end of the power cable so that the flat on the connector is facing the shaft of the motor.
4. Push the cable onto the appropriate mating half until it clicks.
- 5.

If you have:	Do this:
More motors to wire	1. Move to the next motor. 2. Repeat the steps above.
Wired all of your motors	Go to the Commissioning chapter for your specific system.

Connecting Your External Shunt Resistor

These procedures assume that your external shunt resistor is already mounted.

To connect your external shunt resistor:

1. Remove all 24V control power, contactor enable power, and 360/480V AC input power from the system.
- 2.

If your system module is:	Do this:
Series A and B	Go to <i>Connecting Your External Shunt Resistor (Series A and B)</i> .
Series C	Go to <i>Connecting Your External Shunt Resistor (Series C)</i> .

Connecting Your External Shunt Resistor (Series A and B)

1. Open the front door of the 1394 system module.
2. Remove and discard the COL/INT jumper wire from the power terminal block in the lower right corner, as shown in the figure below.

Figure 3.15
1394 System Module Jumper Removal (Series A and B)

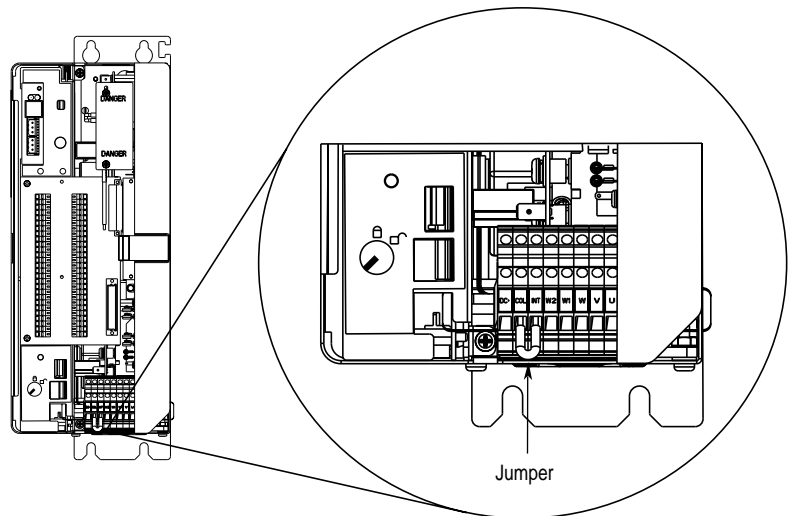

3. Install the jumper block in the P1 position, which is located directly behind the Status LED, as shown in the figure below.

Figure 3.16
1394 System Module Jumper Installation (Series A and B)

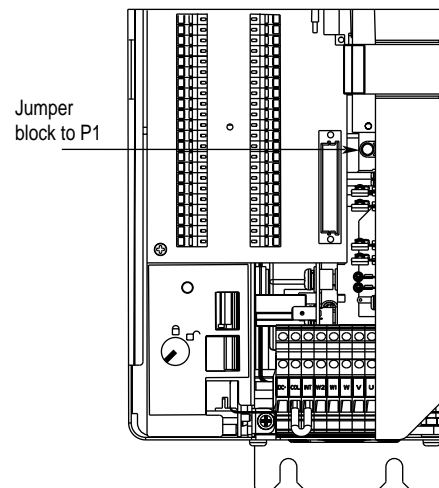

4. Install and tighten the resistor wire with the fuse in the DC+ terminal on the power terminal block in the lower right corner.
5. Install and tighten the other resistor wire in the COL terminal on the power terminal block in the lower right corner.

Connecting Your External Shunt Resistor (Series C)

1. Locate and unplug the J11 connector on the bottom of the system module.
2. Remove and discard the jumper wire between J11-1 and J11-2, as shown in the figure below.

Figure 3.17
1394 System Module Jumper Removal (Series C)

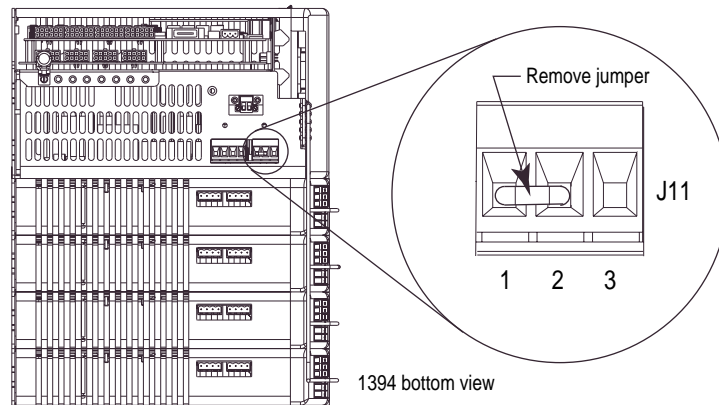

3. Install the shunt resistor wire leading to the fuse in connector J11-1.
4. Install the other shunt resistor wire in connector J11-3.
5. Tighten the J11 connector screws (torque value = 0.56-0.62 N-m, 5.0-5.6 lb-in.).

Connecting Your Shunt Module (required for 22 kW system)

The procedures in this section assume that your shunt module is already mounted. Wiring the shunt module consists of connecting power from the system module and, depending on the shunt module you ordered, connecting power to the fan inside the module.

Required Tools and Equipment

The required tools and equipment are:

- A small, flathead screwdriver
- User-supplied power wiring
- The two fan jumpers that came with your 1394-SR36AF shunt module.

Wiring the Shunt Module Power

There are three types of cable that can be used to connect the 1394 shunt module to your 1394 system module. All shunt power wiring should meet the following general specifications:

- 8 AWG (8.4 mm²)
- 105° C
- 600V
- Maximum length of each wire is 3.05 m (10 ft.).
- If you mount the shunt module outside the cabinet, the shunt power cables and fan wiring must be inside metal conduit to minimize the levels of EMI and RFI.

To minimize the levels of EMI and RFI inside your cabinet, we recommend you:

- Use a single cable that contains a twisted pair with an overall shield. The shunt module is designed to accept a metal conduit which will also act as an overall shield.
- Route your shunt power cables with motor power cables.
- Separate shunt power cables from other sensitive, low voltage signal lines.

The table below details your shunt power wiring options.

For this Type of Cable:	Twist Conductors (Y/N):
Twisted pair with overall shield	N
Twisted pair (no shield)	N
Discrete conductors ¹	Y (2 twists per foot)

¹ Twisting cancels most of the RFI noise for the two conductors. Refer to Figure 3.18 and Figure 3.19 for more information.

To connect the shunt module to the 22 kW system module:

1. Verify that there is no 24V control or 360/480V power applied to the system.
2. Open the front door of the system module.
3. Insert one end of one user-supplied 8.4 mm² (8 AWG), 105° C (221° F), 600V, shielded wire in the terminal block labeled COL.
4. Insert one end of the other user-supplied 8.4 mm² (8 AWG), 105° C (221° F), 600V, shielded wire in the terminal block labeled DC +.
5. Tighten both screw terminals (torque = 2.5 N-m, 22.1 lb-in.).
6. Gently pull on each wire to make sure it does not come out of its terminal. Re-insert and tighten any loose wires.

Figure 3.18
Routing Shunt Module Wiring When the Module is Outside the Cabinet

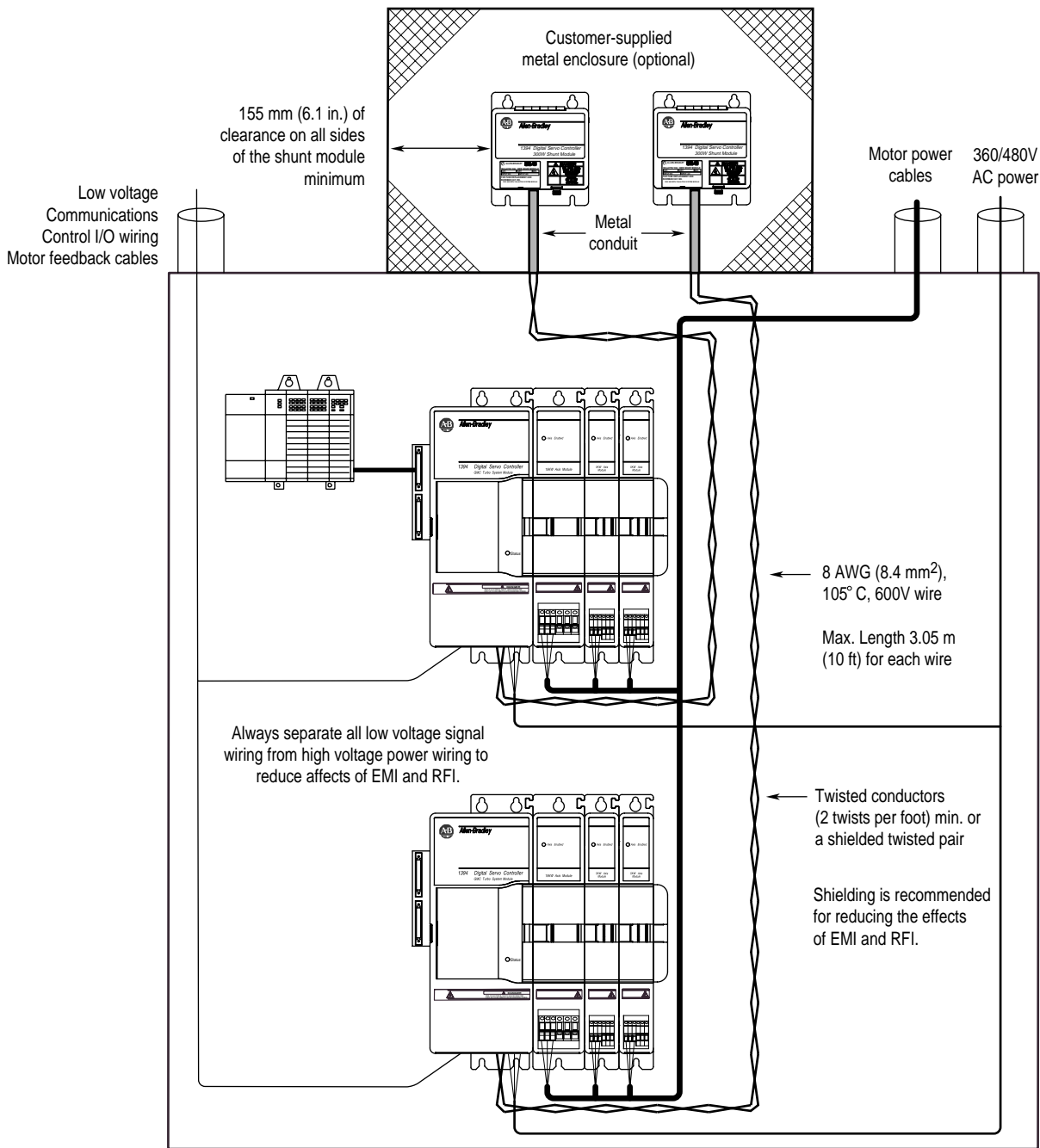

ATTENTION: The resistors inside the 1394 shunt module can reach temperatures in excess of 350° C (662° F). Be sure to provide appropriate guarding to avoid hazard of shock or burn and ignition of flammable material. Install per local codes.

Figure 3.19
Routing Shunt Module Wiring When Module is Inside the Cabinet

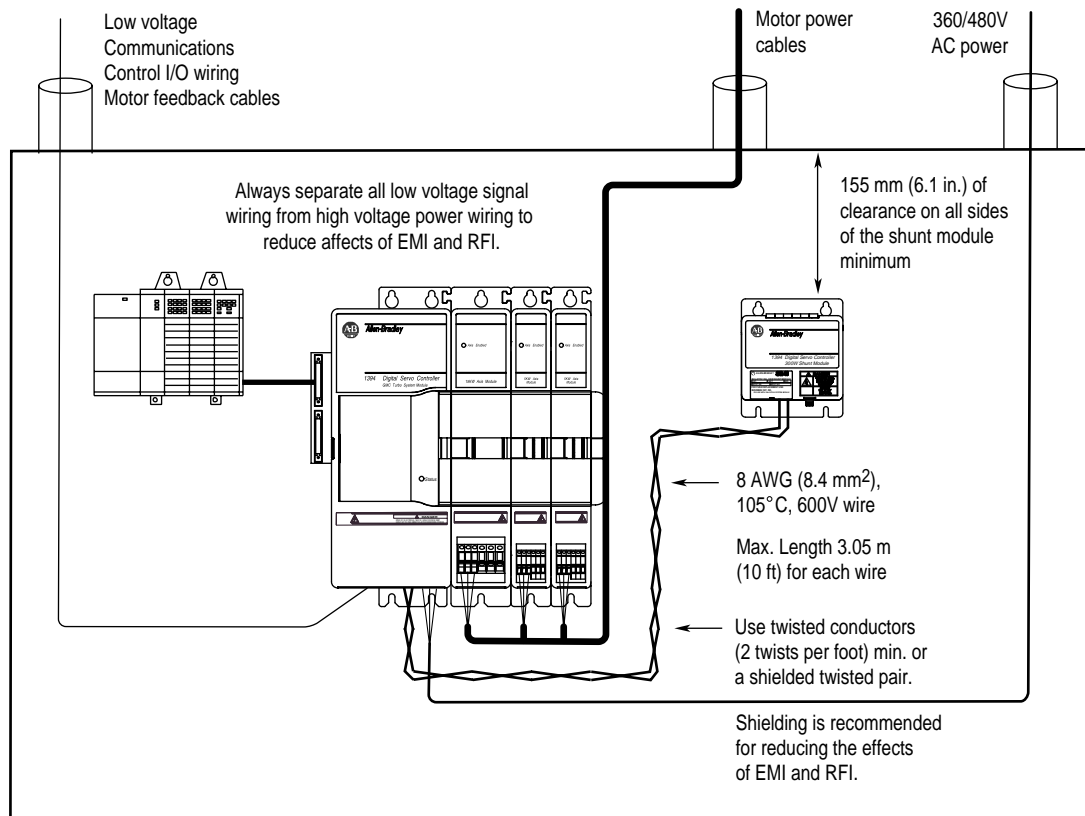

ATTENTION: To avoid burn hazard and ignition of flammable material, be sure to provide appropriate guarding. The resistors inside the 1394 shunt module can reach temperatures in excess of 350° C (662° F). Install per local codes.

7. Open the front door of the shunt module.
8. Insert the wire from the system module terminal block labeled COL in the top terminal on the left side of the shunt module. Refer to Figure 3.20 for the terminal's location.
9. Insert the wire from the system module terminal block labeled DC+ in the bottom terminal on the left side of the shunt module. Refer to Figure 3.20 for the terminal's location.

Figure 3.20
Terminating Wires at the Shunt Module

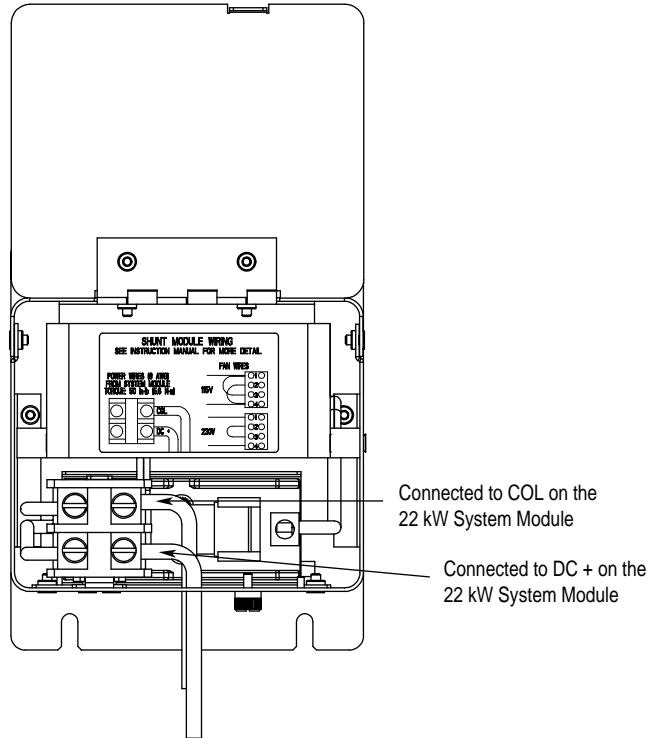

10. Tighten both screw terminals (torque = 2.5 N-m, 22.1 lb-in.).
11. Gently pull on each wire to make sure it does not come out of its terminal. Re-insert and tighten each loose wire.
- 12.

If your shunt module:	Then:
Has a Fan	Go to <i>Wiring the Shunt Module Fan Power</i> .
Does not have a fan	Finish installing your system.

Wiring Shunt Module Fan Power

This procedure assumes that you have bonded, mounted, and wired the power to your shunt module. The shunt fan can be wired for 115V or 230V input. Use 16 AWG 1.3 mm² [machine tool, 75° C (167° F)] copper wire for all fan power wiring. The current draw of each shunt module fan is shown in the table below.

For this input power:	The current draw is:
115V AC	.2A
230V AC	.1A

Important: If you mount the shunt module outside the cabinet, the shunt fan power wiring must be inside metal conduit to minimize the levels of EMI and RFI.

To wire the shunt fan for 115V:

1. Verify that all 24V control or 360/480V input power is removed from the system.
2. Open the front door of the shunt module.
3. Using a flat screw driver, remove the plate that covers the fan wire access hole located on the bottom right side of the module.
4. Insert one wire from the 115V AC power supply into terminal 1.
5. Insert the other wire from the 115V AC power supply into terminal 4.
6. Insert one of the jumper wires that came with your shunt module into terminals 1 and 3. Refer to Figure 3.21 for the jumper's location.
7. Insert the other jumper wire that came with your shunt module into terminals 2 and 4. Refer to Figure 3.21 for the jumper's location.
8. Tighten all screw terminals.
9. Gently pull on each wire to make sure it does not come out of its terminal. Re-insert and tighten any loose wires.

To wire the shunt fan for 230V:

1. Verify that all 24V control or 360/480V input power is removed from the system.
2. Open the front door of the shunt module.
3. Using a flat screw driver, remove the plate that covers the fan wire access hole located on the bottom right side of the module.
4. Insert one wire from the 230V AC power supply into terminal 1.

5. Insert the other wire from the 230V AC power supply into terminal 4.
6. Insert the jumper wire that came with your shunt module into terminals 2 and 3. Refer to Figure 3.21 for the jumper's location.
7. Tighten all screw terminals.
8. Gently pull on each wire to make sure it does not come out of its terminal. Re-insert and tighten any loose wires.

Figure 3.21
Wire Locations for the Shunt Module Fan

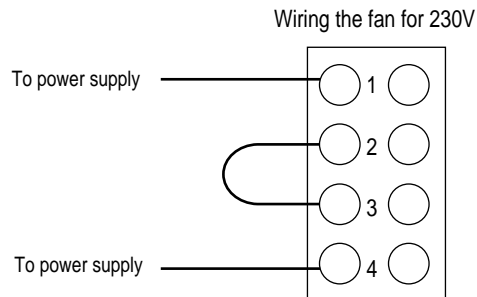
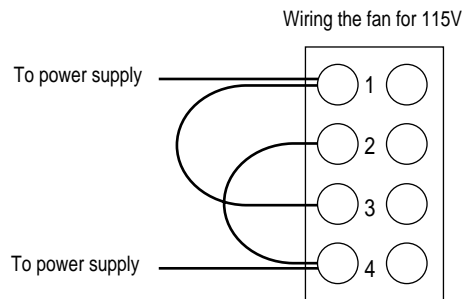

Wiring 1394 GMC and GMC Turbo Systems

Chapter Objectives

This chapter covers the following topics:

- Understanding GMC and GMC Turbo wiring and connections
- Understanding input wiring board layout
- Connecting your communication cables
- Connecting a GMC and GMC Turbo to a 1394-DIM
- Understanding DIM signals
- Wiring and Configuring an External Drive to the 1394-DIM

Finding Additional Wiring Information for 1394 Systems

This chapter provides signal wiring and connection information required for the 1394 GMC and GMC Turbo system modules only.

For additional wiring information on:	Refer to the following:
1394 Analog Servo system modules	<i>Chapter 5 (Wiring Your 1394 Analog Servo System)</i> in this manual.
CNC Interface or 9/440 system modules	<i>9/Series CNC Hardware Integration and Maintenance Manual</i> (publication 8520-6.2).
1394 SERCOS system modules	<i>1394 SERCOS Multi-Axis Motion Control System User Manual</i> (publication 1394-5.20)

Understanding GMC and GMC Turbo Wiring and Connections

The 1394 GMC and GMC turbo contain an integrated IMC S Class motion controller that is functionally equivalent to the IMC S Class Compact. GMC and GMC Turbo system modules provide connections for the following:

- Motor feedback (resolvers)
- Auxiliary encoders (optional)
- RS-232 and RS-422 serial communications
- Remote I/O
- Flex I/O
- DH-485
- AxisLink
- SLC Interface (Direct connection) (Turbo only)

Understanding Input Wiring Board Layout

The input wiring board provides terminating points at TB1 and TB2 for the various control signals. The figure below shows the locations of the various signal terminations.

Figure 4.1
Input Wiring Board for 1394x-SJTxx-C, -C-RL and -T, -T-RL

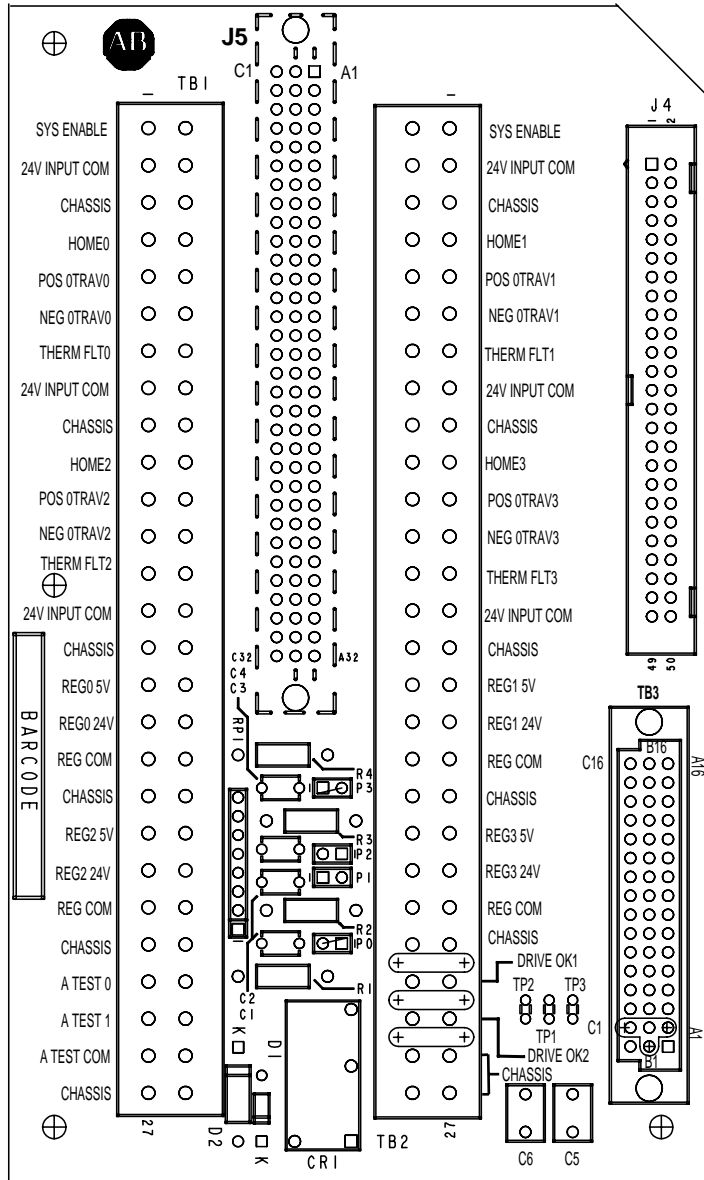

Important: Use the terminal operating tool, as shown in Figure 4.3 (supplied with the system module), to help you insert and remove wires on the input wiring board.

Figure 4.2
Input Wiring Board for 1394C-SJTxx-L and -L-RL

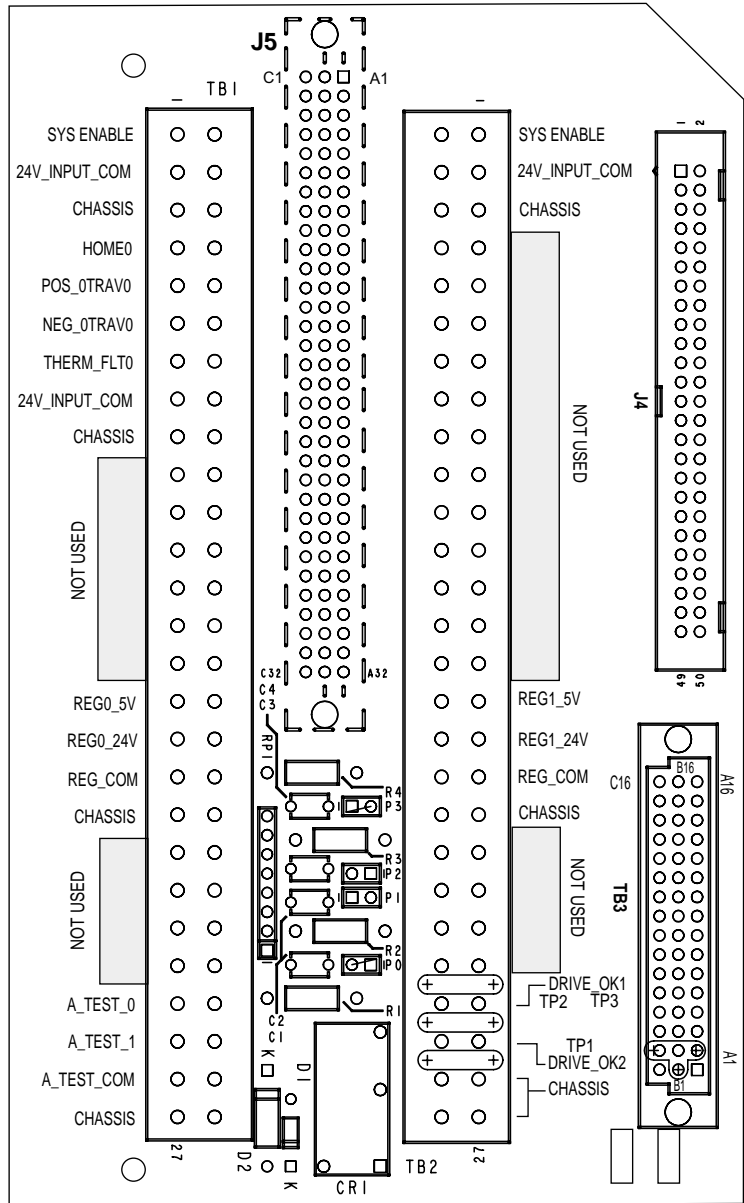

Important: Use the terminal operating tool, as shown in Figure 4.3 (supplied with the system module), to help you insert and remove wires on the input wiring board.

Using the Terminal Operating Tool to Insert Wires

Each system module you order comes with a terminal operating tool that allows you to easily insert your wires into the terminals. Refer to *Appendix D* for the part number.

Figure 4.3
Terminal Operating Tool

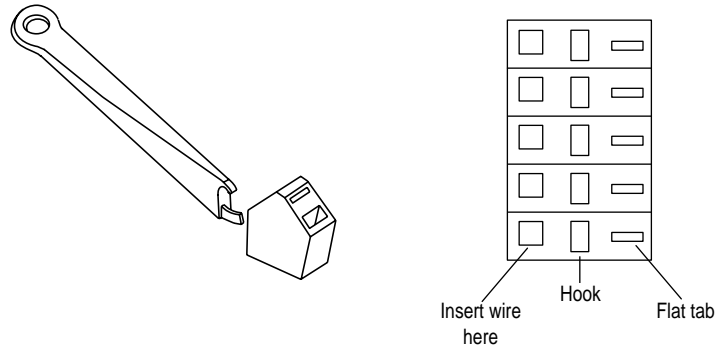

To use the terminal operating tool with TB1:

1. Put the hook into the hook slot with tab end of the tool to your left.
2. Gently push the tool to the right to open the wire slot.
3. Insert the wire.
4. Gently release the tool by moving it to the left.
5. Reverse directions for TB2.

Input Wiring Board Signal Descriptions

The following tables provide descriptions of the various control signals shown in Figure 4.1. Terminate the signals you need for your application using the terminal operating tool.

Wire:	Description:	Terminal connections for 1394x-SJTxx-C, -C-RL and -T, -T-RL systems:	Terminal connections for 1394C-SJTxx-L and -L-RL systems:	Mandatory or Optional:
SYS ENABLE	A 24V DC input is applied to these terminals to enable the system.	Either TB1 or TB2, terminal 1	Either TB1 or TB2, terminal 1	Mandatory
24V INPUT COM	Common grounding point for 24V signals.	TB1 and TB2 terminals 2, 8, and 14	TB1 terminals 2 and 8	Mandatory
CHASSIS	Common chassis ground point.	TB1 terminals 3, 9, 15, 19, 23, and 27 TB2 terminals 3, 9, 15, 19, 23, 26, and 27	TB1 terminals 3,9,19 and 27 TB2 terminals 3,19,26 and 27	Mandatory
HOME0	Home switch inputs for each axis require 24V DC (each), 13 mA to energize. Each input is optically isolated and filtered to minimize switch bounce. Refer to Figure 4.4.	TB1 - 4 (axis 0), TB2 - 4 (axis 1), TB1 - 10 (axis 2), TB2 - 10 (axis 3)	TB1 - 4 (axis 0)	Optional
POS OTRAV0	The positive limit switch inputs for each axis require 24V DC (each), 13 mA to energize. Each input is optically isolated and filtered to minimize switch bounce. Refer to Figure 4.4.	TB1 - 5 (axis 0), TB2 - 5 (axis 1), TB1 - 11 (axis 2), TB2 - 11 (axis 3)	TB1 - 5 (axis 0)	Optional
NEG OTRAV0	The negative limit switch inputs for each axis require 24V DC (each), 12 mA to energize. Each input is optically isolated and filtered to minimize switch bounce. Refer to Figure 4.4.	TB1 - 6 (axis 0), TB2 - 6 (axis 1), TB1 - 12 (axis 2), TB2 - 12 (axis 3)	TB1 - 6 (axis 0)	Optional
THERM FLT0	The thermal fault switch inputs for each axis require 24V DC (each), 12 mA to energize. Each input is optically isolated and filtered to minimize switch bounce. Refer to Figure 4.4.	TB1 - 7 (axis 0), TB2 - 7 (axis1), TB1 - 13 (axis 2), TB2 - 13 (axis 3)	TB1 - 7 (axis 0)	Optional

Figure 4.4
Home, Travel and Thermal Fault Inputs

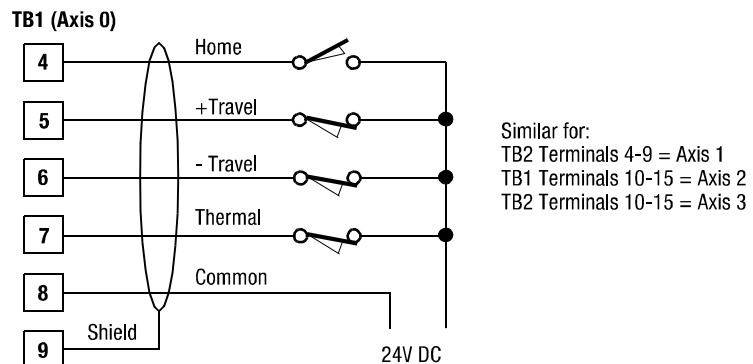

Wire:	Description:	Terminal connections for 1394x-SJTxx-C, -C-RL and -T, -T-RL systems:	Terminal connections for 1394C-SJTxx-L and -L-RL systems:	Mandatory or Optional:
REG 5V, 24V, COM	<p>High-speed, optically-isolated filtered registration input for each axis. Inputs can be either 5 or 24V DC. Refer to Figure 4.5 for typical registration device inputs.</p> <p>Note: To further reduce electrical noise, a dedicated power supply may be required for the registration sensors.</p> <p>You can disable the registration input filters by removing jumpers P0-P3 on the input wiring board.</p>	<p>For 5V TB1 16 (axis 0) TB2 16 (axis 1) TB1 20 (axis 2) TB2 20 (axis 3)</p> <p>For 24V TB1 17 - 18 (axis 0) TB2 17 - 18 (axis 1) TB1 21 - 22 (axis 2) TB2 21 - 22 (axis 3)</p> <p>For COM (used with 5V and 24V) TB1-18 (axis 0) TB2-18 (axis 1) TB1-22 (axis 2) TB2-22 (axis 3)</p>	<p>For 5V TB1 16 (axis 0) TB2 16 (axis 1)</p> <p>For 24V TB1 17 - 18 (axis 0) TB2 17 - 18 (axis 1)</p> <p>For COM (used with 5V and 24V) TB1-18 (axis 0) TB2-18 (axis 1)</p>	Optional
A TEST 1 A TEST 2 A TEST COM	<p>Two software-programmable outputs are available:</p> <ul style="list-style-type: none"> • A voltage corresponding to the motor velocity and direction of rotation will be present between these terminals. $\pm 1.0V/krpm$ is available. Minimum impedance that can be placed across this output is 10k ohm. • A voltage corresponding to positive and negative current will be present between these terminals. $\pm 2.5V$ DC equals 100% of motor continuous current rating. $\pm 5.0V$ DC equals 200%. Minimum impedance that can be placed across this output is 10k ohms. <p>Any axis analog current/voltage output may be linked to either analog output using internal software parameters. By default Axis 0 velocity is linked to A TEST 0 and Axis 0 current is linked to A TEST 1.</p>	TB1-24 (A TEST 0) TB1-25 (A TEST 1) TB1-26 (A TEST COM)	TB1-24 (A TEST 0) TB1-25 (A TEST 1) TB1-26 (A TEST COM)	Optional
DRIVE OK 1/2	<p>When you apply 24V AC/DC control power to the system and no system faults are detected, the Drive OK relay contact closes. The contact remains closed until a drive fault occurs, the DC bus voltage is lost, or you remove 360/480V input power from the system module. If a drive fault is detected or the DC bus voltage is lost, the relay contact opens. You can wire the Drive OK contacts into the Estop string to open the main power contactor if a fault occurs. The contact rating is 115V AC or 24V DC, 1A.</p>	TB2 terminals 24 and 25	TB2 terminals 24 and 25	Mandatory

Figure 4.5
Typical Registration Inputs

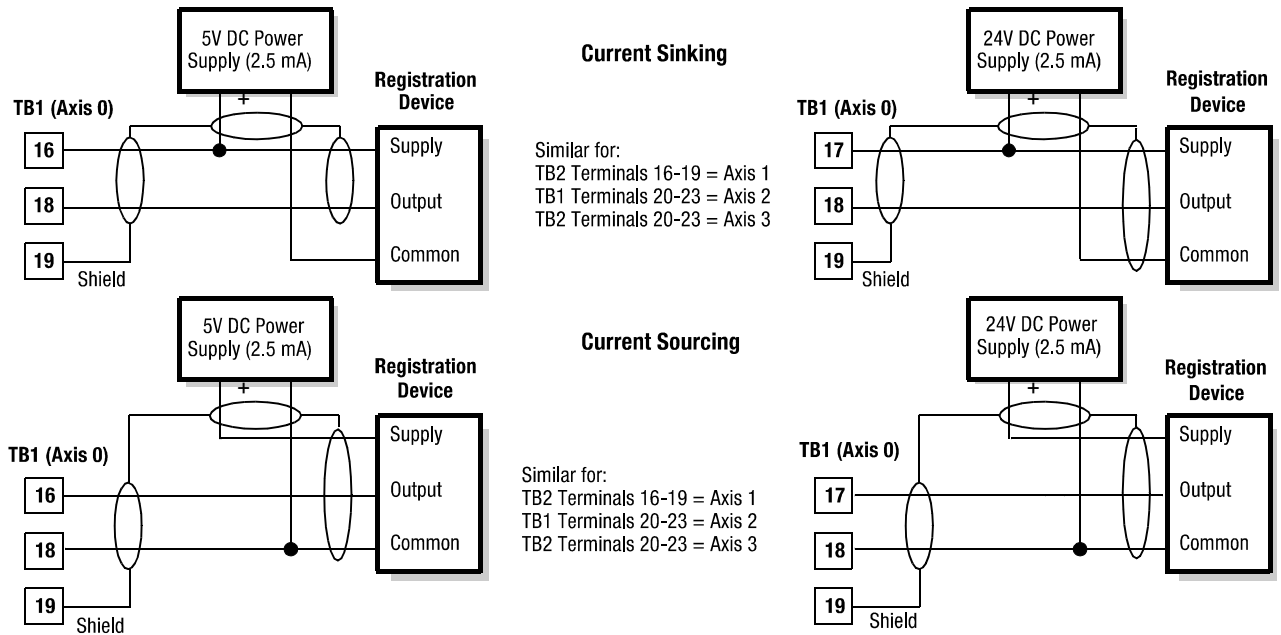

Important: Connections shown are typical only. Some input devices vary in their specific connections. Consult the wiring diagram for your device.

Important: If you are using current sinking, you can only use one device per controller.

Connecting Your Communication Cables

The 1394 GMC and GMC Turbo system modules provide the following communication options:

- Encoder feedback
- RS-232 and RS-422 serial communications
- DH-485
- AxisLink
- Remote I/O
- Flex I/O
- SLC Interface (Direct connection) (Turbo only)

Figures 4.6, 4.7, and 4.8 show the locations of the various communication connections.

Figure 4.6
Inside the 1394 GMC and GMCTurbo (catalog number 1394-SJT22)

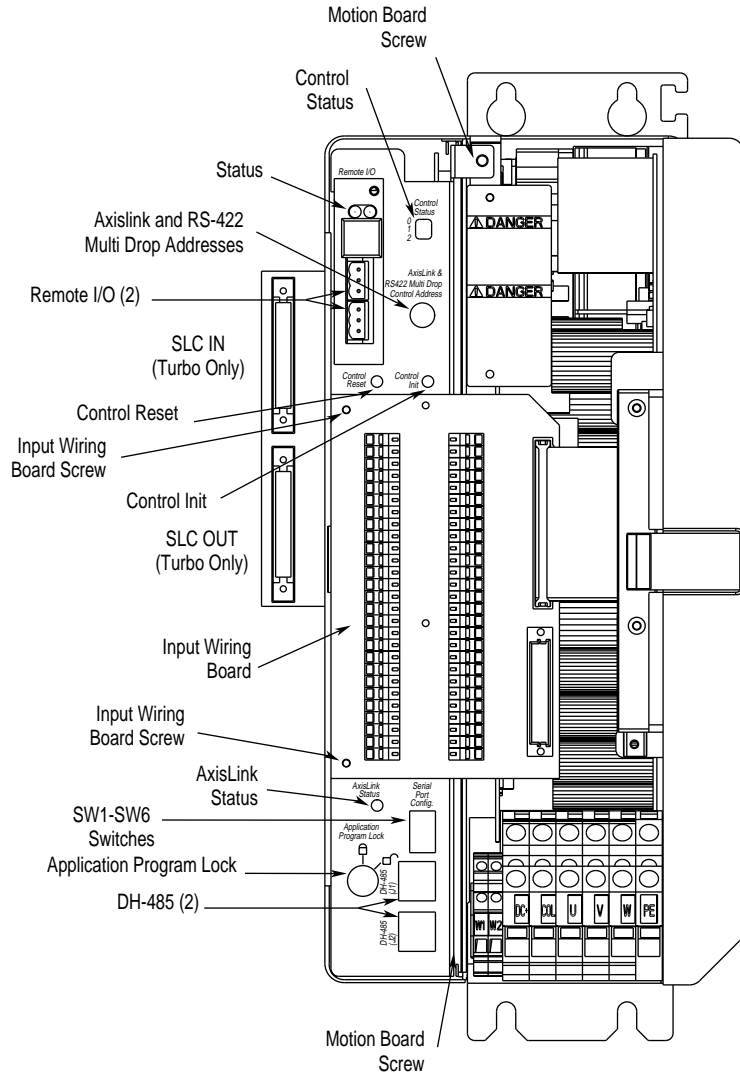

Figure 4.7
Bottom View of the 1394-SJTxx-C and -T

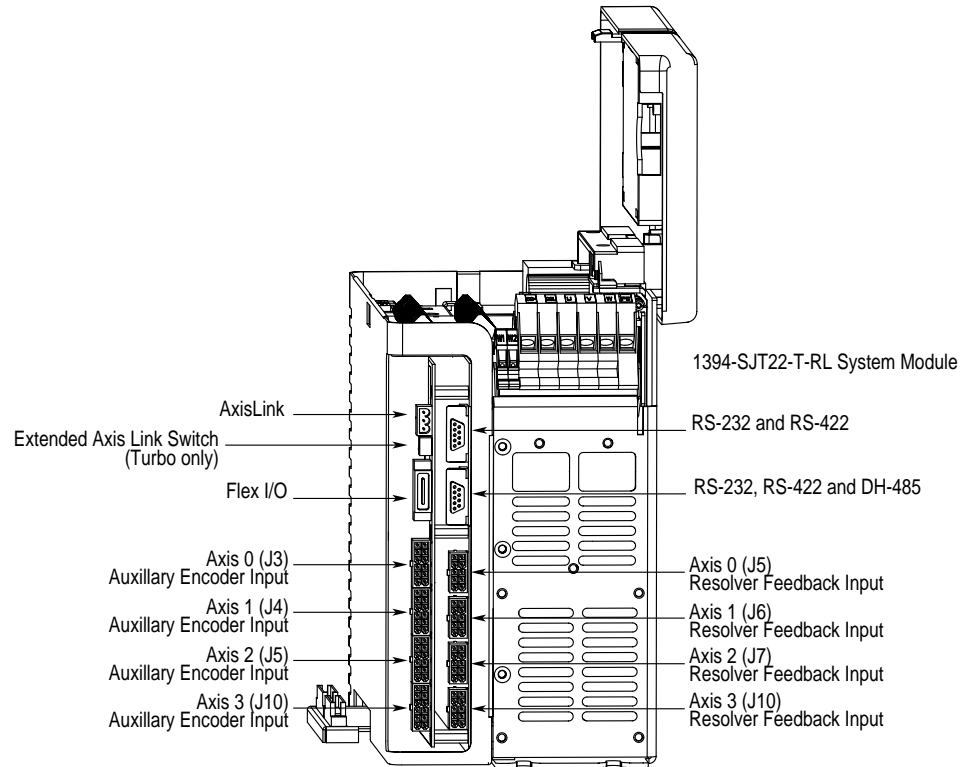
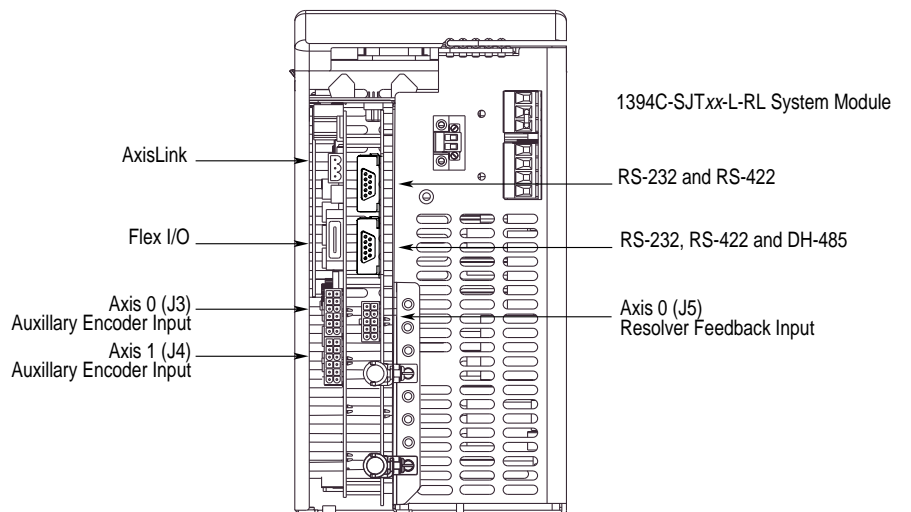

Figure 4.8
Bottom View of the 1394C-SJTxx-C, -L, and -T



Encoder Feedback Wiring

These connectors accept encoder feedback signals from an optional encoder. Terminal 10 requires a user-supplied, regulated +5V DC ($\pm 5\%$). We recommend Belden #9728 wire or equivalent. When you use a 5 volt power supply, there is a maximum distance between the encoder and 1394 of 12.2 meters (40 feet).

The 1394 interface circuitry requires 0.325A to operate. Any additional devices connected to the 1394, such as incremental encoders, may require an additional 0.2A per device to operate. Check your device for operational requirements.

Make the encoder feedback connections according to the table below. Connectors are located on the bottom of your system module (refer to Figure 4.7 for 1394x-SJTxx-C and -T systems and Figure 4.8 for 1394C-SJTxx-L systems).

For this axis:	Connect to this terminal:
0	J3
1	J4
2	J5
3	J10

To improve the bond between the motor feedback cable shield and the system module PE ground, a cable shield clamp is included with the Series C system modules.

Ensure an appropriate amount of the cable insulation and braided shield is removed from the feedback cable. Place the cable wires and exposed braided shield into the cable shield clamp and tighten the clamp screw. Then thread the bracket screw into the bottom of the system module and tighten. Refer to the figure below for an illustration.

Figure 4.9
Series C System Module Cable Clamps

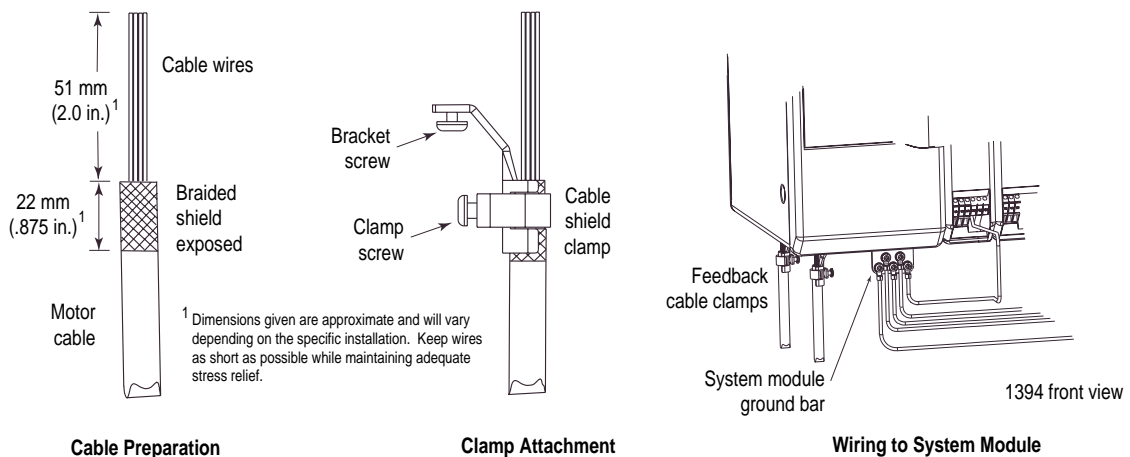

The following cables are available to connect auxiliary encoder feedback to the 1394 GMC and GMC Turbo:

- 1394-GE15 (from the auxiliary incremental encoder to the 1394)
- 1394-GR04 (from the 4100-REC and -AEC to the 1394)

Refer to *Appendix D* for connectors and accessory part numbers. Refer to the table below for interconnection information.

Pin:	Description:
1	Channel A High
2	Channel A Low
3	Channel B High
4	Channel B Low
5	Channel Z High
6	Channel Z Low
7	Strobe x
8	+5V Out
9	Common Output
10	+5V Input (user supplied)
11	Common Input (user supplied)
12	Shield

Refer to *Appendix B* for 1326-CEU-xxx Encoder Feedback Cable information.

Serial Communications

The 1394 provides two optically-isolated RS-232/RS-422 serial ports (CHAN A/J3 and CHAN B/J4). These ports are located on the bottom of the system module. Refer to Figure 4.7 for 1394-SJTxx-C and -T (Series A and B) systems and Figure 4.8 for 1394C-SJTxx-C, -L, and -T (Series C) systems. Both ports use 9-pin, AT compatible, DB-9 connectors and are identically wired.

You can configure CHAN A/port J3 for RS-232(C) or RS-422, and you can configure CHAN B/port J4 independently for RS-232, RS-422, or DH-485. In addition, if you select RS-422 or DH-485, you can configure the port to use a termination resistor (if required). If you select DH-485, port J4 is disconnected. You configure both ports using switches on the system module. Refer to Figure 4.10 for switch settings and Figure 4.6 for location. Both ports are configured for RS-232 operation when they are shipped from the factory.

Figure 4.10
SW1 - SW6 (RS-232/RS-422) Switch Settings

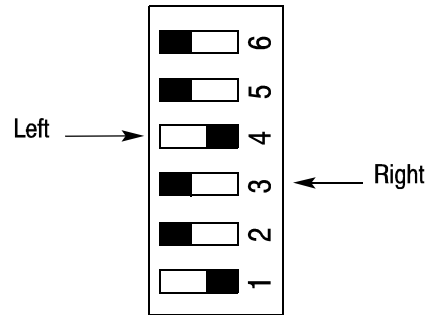

	SW1 Port J1, J2	SW2 Port J4	SW3 Port J3	SW4 Port J1, J2/J4	SW5 Port J4	SW6 Port J3
Left	No DH-485 Terminal	No RS-422 Terminal	No RS-422 Terminal	RS-232/422	RS-232	RS-232
Right	DH-485 Terminal (220Ω)	RS-422 Terminal (220Ω)	RS-422 Terminal (220Ω)	DH-485	RS-422	RS-422

When a port is configured for RS-232 operation, you can connect compatible serial communication devices using common RS-232 cables. Refer to the table below for signal designations and Figure 4.11 for cable recommendations. Refer to the *IMC S Class Motion Control Installation and Setup Manual* (publication 999-122) for multidrop application instructions.

RS-232			RS-422		
Pin	Signal	Description	Pin	Signal	Description
1	NC	No Connection	1	TxD+	Transmitted Data (+)
2	TxD	Transmitted Data	2	TxD-	Transmitted Data (-)
3	RxD	Received Data	3	RxD-	Received Data (-)
4	DTR	Data Terminal Ready	4	TxD+	Transmitted Data (+)
5	Com	Signal Common	5	Com	Signal Common
6	DSR	Data Set Ready	6	TxD+	Transmitted Data (+)
7	RTS	Ready To sent	7	RxD+	Received Data (+)
8	CTS	Clear To Send	8	RxD+	Received Data (+)
9	NC	No Connection	9	NC	No Connection

Refer to *Data Highway Connection* for DH-485 signal designations.

Important: The RTS/CTS and DSR/DTR signals are internally jumpered to allow you to use standard RS-232 cables with serial devices requiring hardware handshaking.

Figure 4.11
RS-232/422 Cable Signals

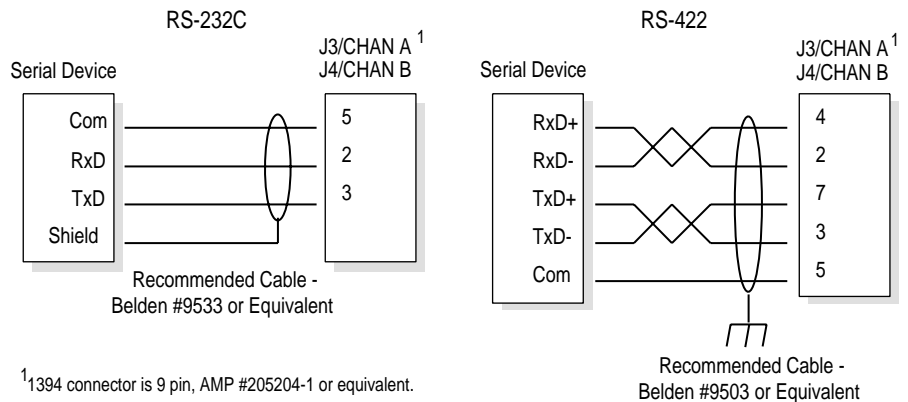

Data Highway Connection

The 1394 provides two optically-isolated ports (J1 and J2) for Data Highway 485 (DH-485) communication. Both connectors are wired identically (you can use either one). A telephone-type connector provides the interface with the following signal designations.

Pin:	Signal:	Description:
1	Data A	Data A Transmit
2	Data B	Data B Transmit
3	NC	No Connection
4	NC	No Connection
5	Tx Enab	Transmitted Data Enable
6	Shield	Signal Shield
7	Com	Signal Common
8	NC	No Connection

AxisLink

AxisLink provides a network to transfer data between multiple nodes (up to eight standard) that allows you to synchronize complex motion applications. For example, these nodes can be eight GMC system modules, one ALEC and 7 GMC system modules, or some other combination. AxisLink allows one 1394 to be used as a master axis for electronic gearing, camming, etc. on other systems. Using the Extended Node option in GML version 3.9.1 (or higher) with firmware version 3.5 (or higher) you can link up to 16 nodes. Connect the AxisLink cable to J1 with a three pin connector as shown in Figure 4.12. The maximum end-to-end length for Daisy-Chain cabling configurations is 25 m (82 ft). The minimum distance between AxisLink nodes is 0.9 m (3 ft). Refer to Figures 4.7 and 4.8 for the AxisLink connector's location.

Figure 4.12
AxisLink Connections for a GMC System

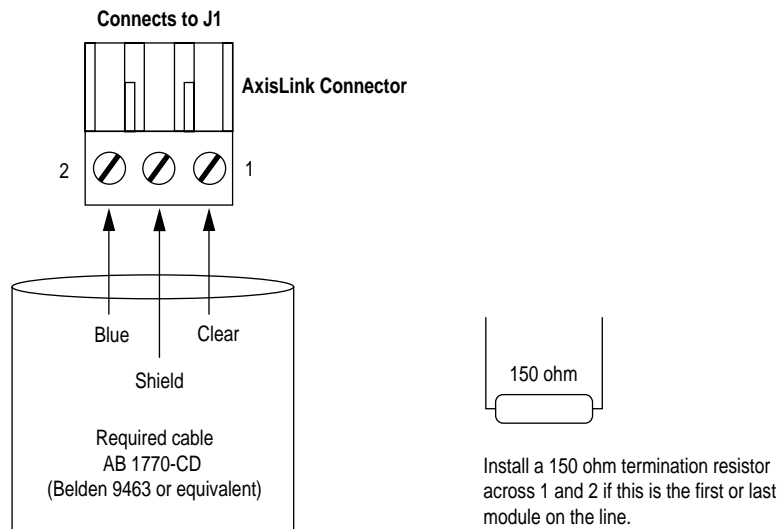

Important: All nodes on the same AxisLink network should be operated at the same servo update rate.

Important: Select your AxisLink node address (0-7) using the front panel switch (see Figure 4.6 for the switch's location) (standard mode only). Do not use positions 8 or 9.

GMC Turbo System

For those applications that require longer AxisLink cable lengths, the GMC Turbo offers the AxisLink Extended Length option. The Extended Length option allows the user to support up to eight nodes for a maximum end-to-end cable length of 125 m (410 ft) (user supplied cable). To enable the Extended Length option, set the switch located between the Flex I/O and AxisLink connectors on the bottom of the GMC Turbo system module. See Figure 4.7 for the switch's location and Figure 4.14 for switch settings.

The Extended Node option allows the user to support up to 16 nodes for a maximum end-to-end cable length of 25 m (82 ft). This feature is enabled in GML version 3.9.1 (or higher) with Firmware version 3.5 (or higher).

Important: You cannot use the Extended node option if the Extended Length option is enabled.

Figure 4.13
AxisLink Connections for a GMC Turbo with Extended Length Option Enabled

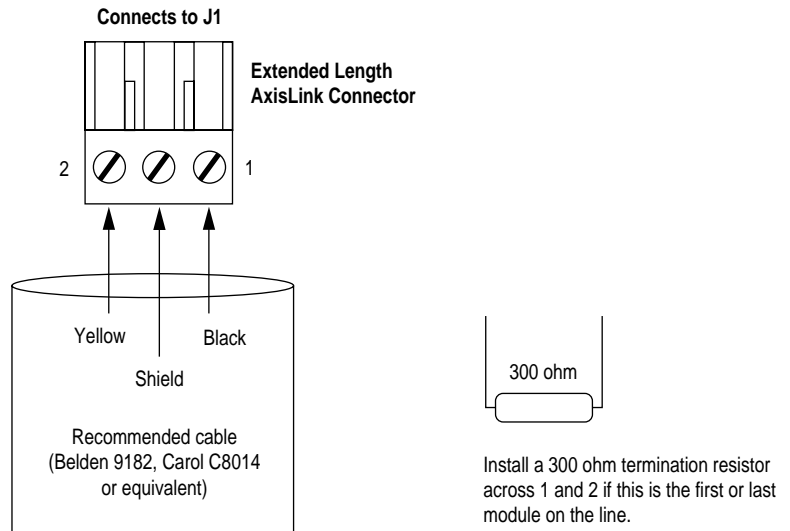
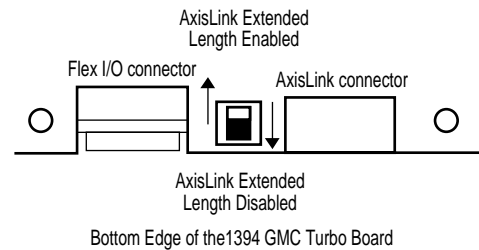

Figure 4.14
AxisLink Extend Length Switch Setting



Remote I/O

The Remote I/O (RIO) interface allows the 1394 to communicate with Allen-Bradley position controllers or other RIO devices. Two identical connectors (CHAN A/P3 and CHAN B/P4) are provided at the top of the Motion Drive Module. A three-pin connector is used for the interface. Refer to the *Installation Guidelines for the Twinaxial Cable* (publication 92-D1770-BCO) for more information.

Figure 4.15
Remote I/O Connections

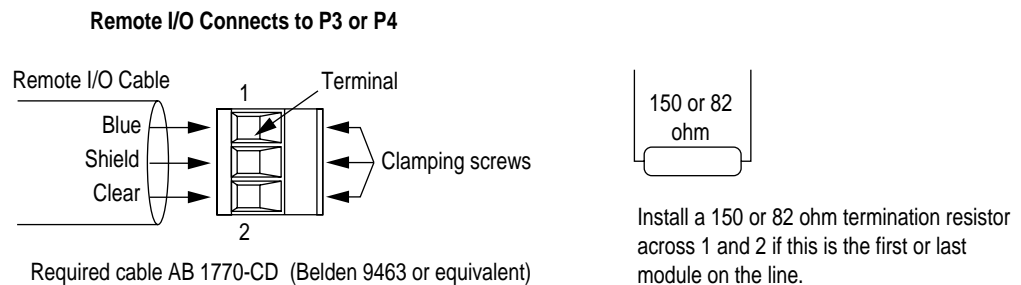

Flex I/O

Flex I/O provides general purpose discrete inputs, discrete outputs, analog inputs and analog outputs (J2). The Flex I/O Module is connected to the 1394 with a 4100-CCF1 (maximum cable length is 305 mm (12 in.) or 4100-CCF3 cable (maximum cable length is 0.91m (3 ft). Up to eight modules of the following types can be connected in any order.

- 1794-IB16 16 Discrete Inputs (24V DC)
- 1794-OB16 16 Discrete Outputs (24V DC)
- 1794-IE8 8 Analog Inputs
- 1794-OE4 4 Analog Outputs
- 1794-IA8 8 115AC Discrete Inputs
- 1794-OA8 8 115V AC Outputs
- 1794-IE 4XOE 2 Analog combination module
- 1794-IB10XOB6 Discrete combination module
- 1794-OW8 Relay output module
- 1794-IF4I Isolated analog input module
- 1794-OB16P Discrete output (protected)

A 1794-ASB adapter is not required. Use a 4100-CCF1 or 4100-CCF3 cable to connect the 1394 to Flex I/O modules.

SLC Interface

The GMC Turbo (catalog number 1394x-SJTxx-T) can connect directly to an SLC 5/03, 5/04, or 5/05 back plane using a 1746-C7 or -C9 cable. The SLC processor recognizes the GMC Turbo as an intelligent SLC module.

The GMC Turbo supports the transfer of input/output image files and M0/M1 files.

If you are using:	Refer to:	Publication number:	For this information:
GML Commander 4.x.x	GML Commander Reference Manual	GMLC-5.2	Programming
GML 3.x.x	GML Programming Manual, Document Update	999-104-DU1	Programming
	GML Programming Manual, Document Update	999-104-DU1.1	1394 SLC Interface

The figure below shows the location of the GMC Turbo to SLC connectors.

Figure 4.16
Connecting a GMC Turbo to an SLC

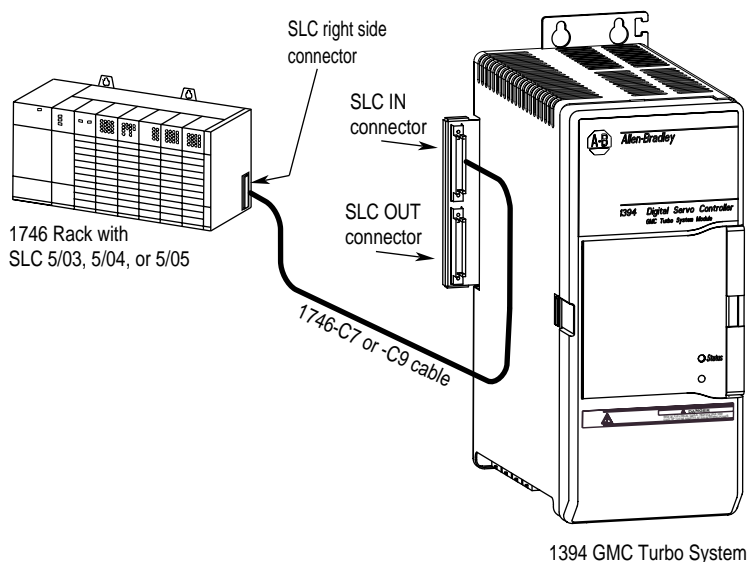

ATTENTION: To avoid injury or damage to equipment do not install SLC interface cables (catalog numbers 1746-C7 and 1746-C9) while the unit(s) is powered up.

ATTENTION: SLC Interface faults will not automatically shut down or stop the axes or application program operating in the 1394 GMC Turbo. These conditions must be handled in a safe manner with the user's application program.

Figure 4.17
Configurations for Connecting a GMC Turbo to an SLC

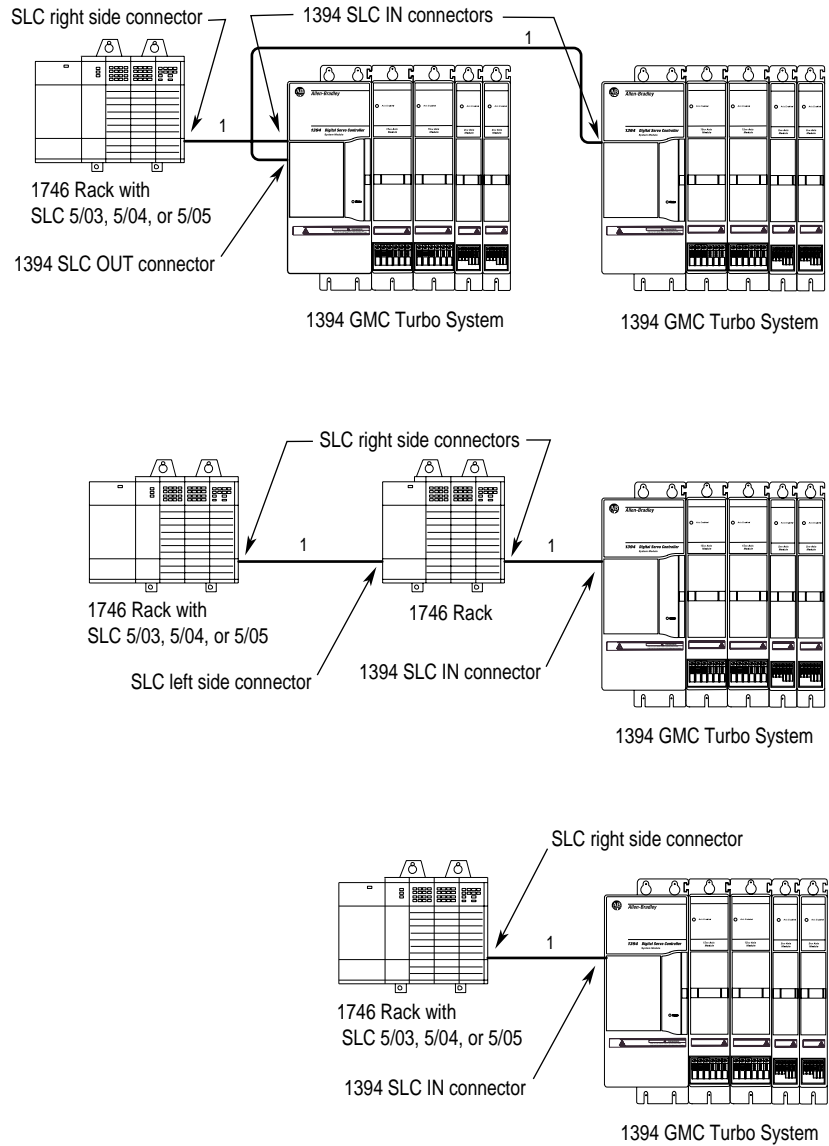

¹ Use cable 1746-C7 or 1746-C9 to connect the 1394x-SJTxx-T to the SLC.

Important: The figure above shows connection information only and does not imply a specific mounting configuration.

Connecting a GMC and GMC Turbo to a 1394-DIM

The 1394-DIM acts as an interface between one 1394 GMC/GMC Turbo system module and the external axis drive(s).

On the 1394x-SJTxx-C, -C-RL, -T, and -T-RL, the 1394-DIM acts in place of one to four axis modules. On the 1394C-SJTxx-L and -L-RL the 1394-DIM acts in place of one axis module. The 1394-DIM passes a standard servo output signal from the system module to each external drive connected to the 1394-DIM. Using a 1394-DIM as part of a 1394 system lets you control external drives and motors of any size.

1394-DIM System Example

The figure below shows an example of a 1394 GMC/GMC Turbo System after connecting a 1394-DIM.

Figure 4.18
A 1394-DIM Connected to a GMC or GMC Turbo

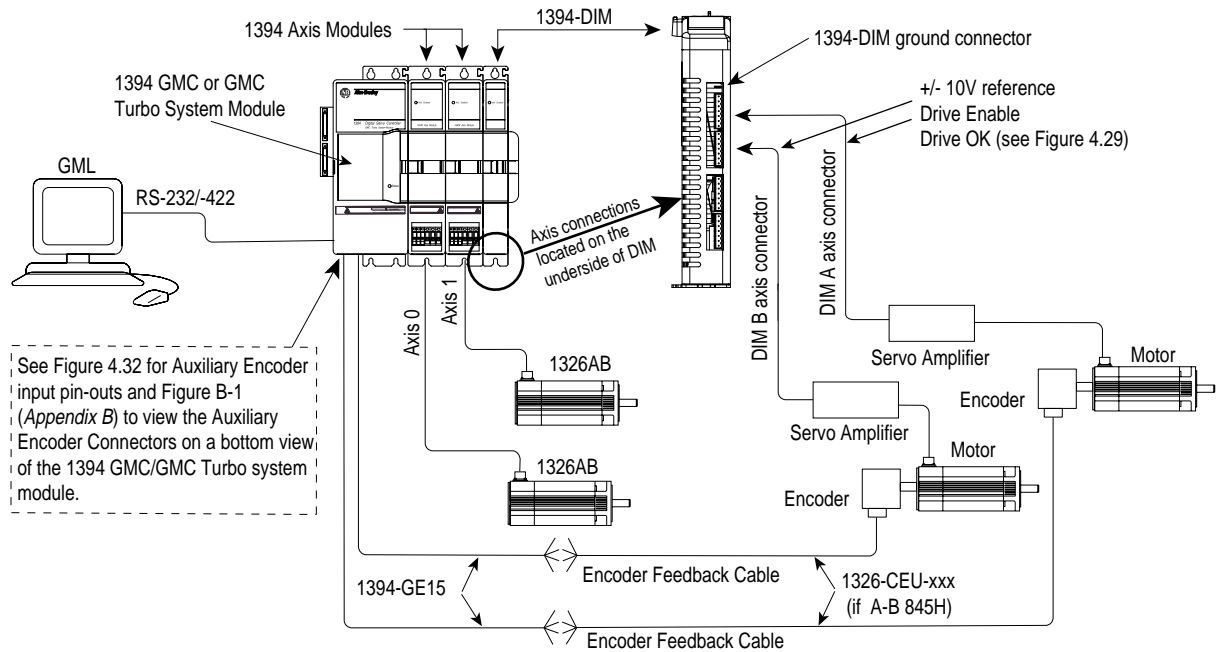

Figure 4.18 shows the 1394-DIM connected to a 1394 GMC Turbo with two 1394 axis modules. A 1326AB-Bxxxx motor is directly connected to each of the 1394 axis modules. Two servo amplifiers with motors are connected to the 1394-DIM. It can accept two because there are two axis modules connected to the 1394 GMC Turbo. The encoders attached to the motors have encoder feedback cables connected to the system module.

1394-DIM with 1398-DDM-xxx System Example

Figure 4.19 shows the 1394-DIM connected to a 1394 GMC Turbo with two 1394 axis modules and a 1398-DDM-xxx servo controller. A 1326AB-Bxxxx motor is directly connected to each of the 1394 axis modules. One servo amplifier with motor is connected to the 1394-DIM.

Figure 4.19
1394-DIM with 1398-DDM-xxx System Example

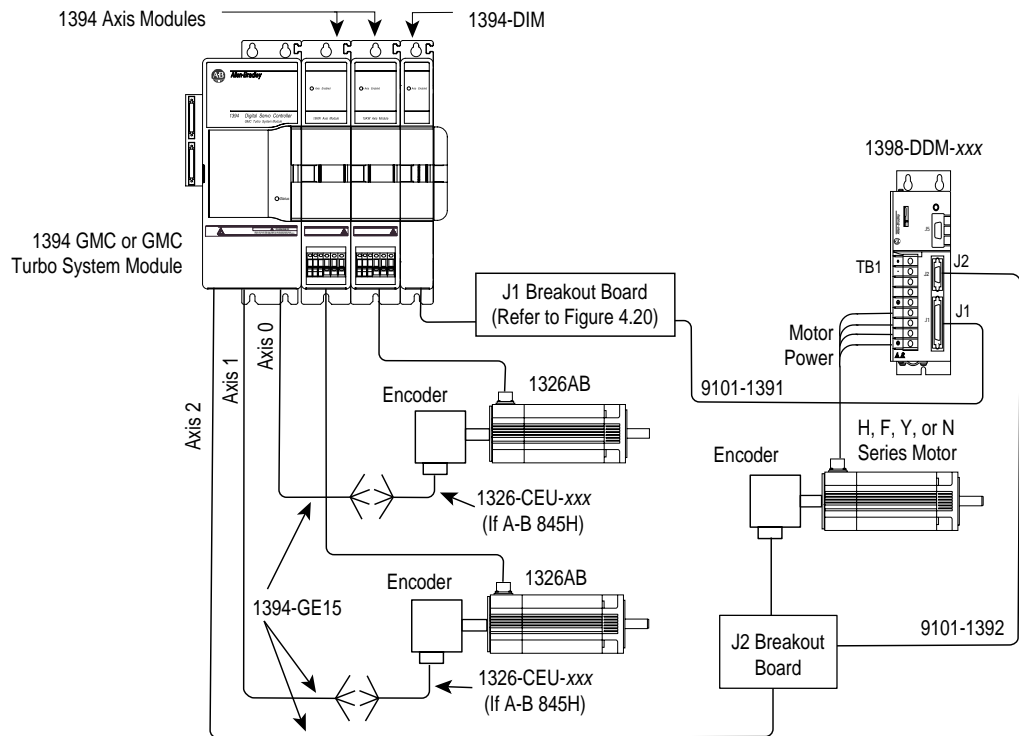
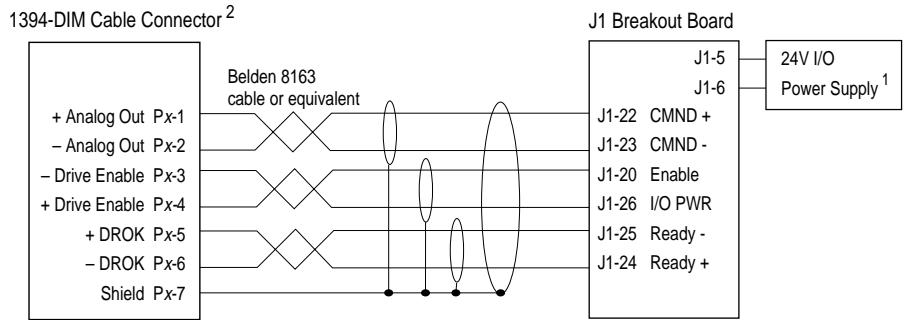

Figure 4.20 shows the J1 breakout board interconnect details between the 1394-DIM and the 1398-DDM-xxx. Refer to *ULTRA 200 User Manual* (publication 1398-5.0) and *ULTRA 100 User Manual* (publication 1398-5.2) for more information.

Figure 4.20
1394-DIM to J1 Breakout Board Pinouts



¹ Required on ULTRA 100 only

² x = axis controlled by DIM

1394-DIM Configurations

The identity and number of the axes you can connect to a 1394-DIM depends upon the number of 1394 axis modules connected to your 1394 system in addition to the 1394-DIM.

The figure below shows the input connections located on the bottom of a typical 1394 system and a 1394-DIM.

Figure 4.21
A 1394-DIM Connected to a GMC or GMC Turbo

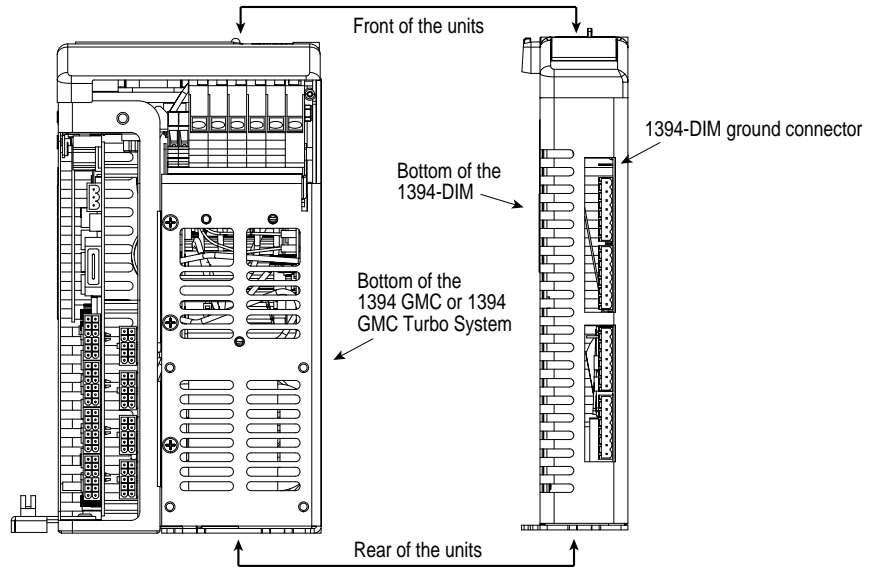

A 1394x-SJTxx-C, -C-RL, -T, and -T-RL system module can control a maximum of four physical axes. The 1394C-SJTxx-L and -L-RL can control only one axis. Each 1394 axis module added to the 1394 system reduces the number of external drives and axes the 1394-DIM can control by one.

For example, if your 1394 system includes three 1394 axis modules, the 1394-DIM can control only one external drive and axis. See the following configuration information.

Number of 1394 axes:	Maximum number of DIM-controlled axes:
4	0
3	1
2	2
1	3
0	4

Important: You can add only one 1394-DIM to a 1394 system.

Important: The system requires 360/480V AC three-phase input power to run, even if the 1394-DIM is configured for four external drives.

Configuration Examples

The following examples show a variety of ways to incorporate the 1394-DIM into a 1394 GMC/GMC Turbo System. The examples show the input connections located on the bottom of a typical 1394 system and a 1394-DIM.

The example below shows two 1394 axes and two DIM output axes.

Figure 4.22
1394-DIM with Multiple Axis Modules

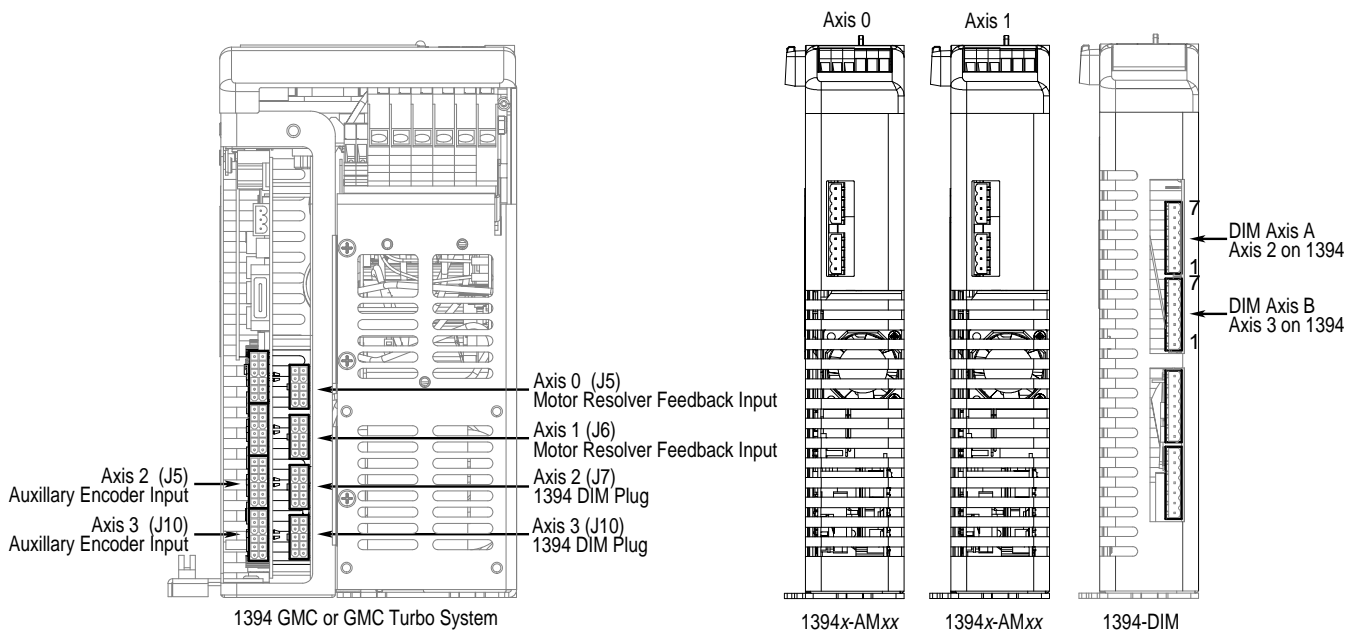

The example below shows one 1394 axis and one DIM output axis.

Figure 4.23
1394-DIM with Single Axis Module

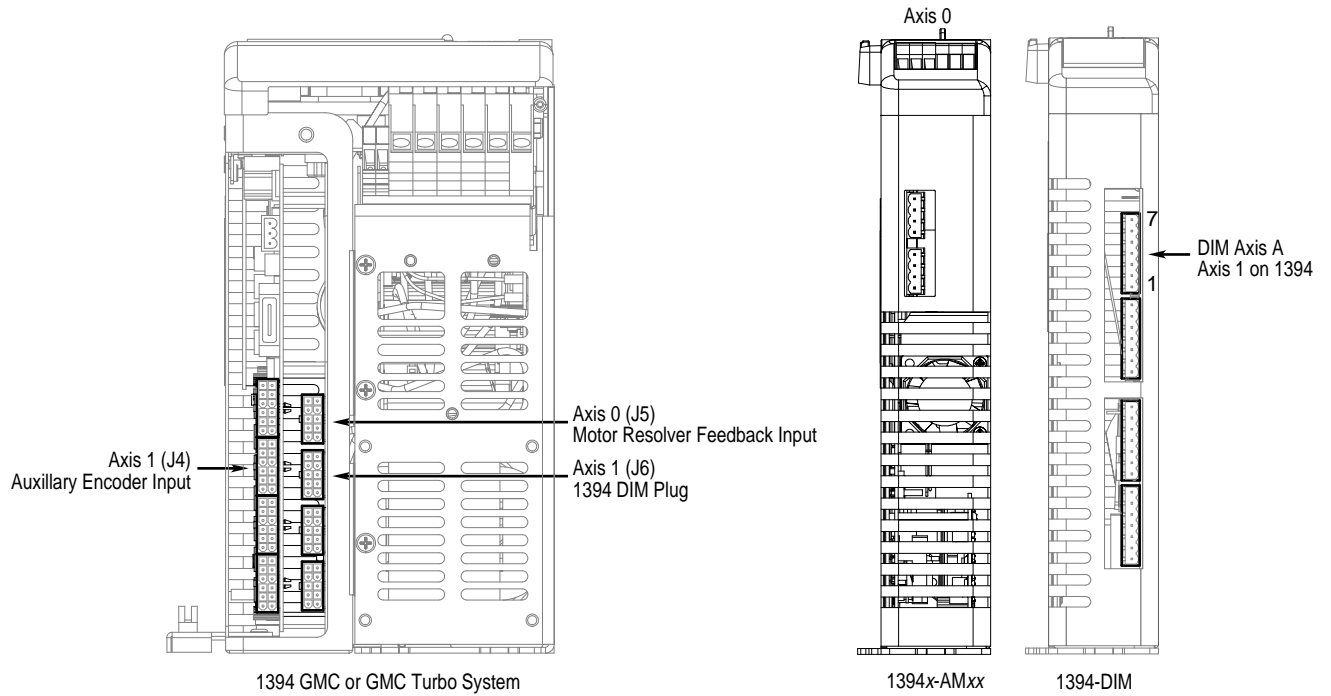

The example below shows no 1394 axes and four DIM output axes.

Figure 4.24
1394-DIM Not Connected to Axis Module

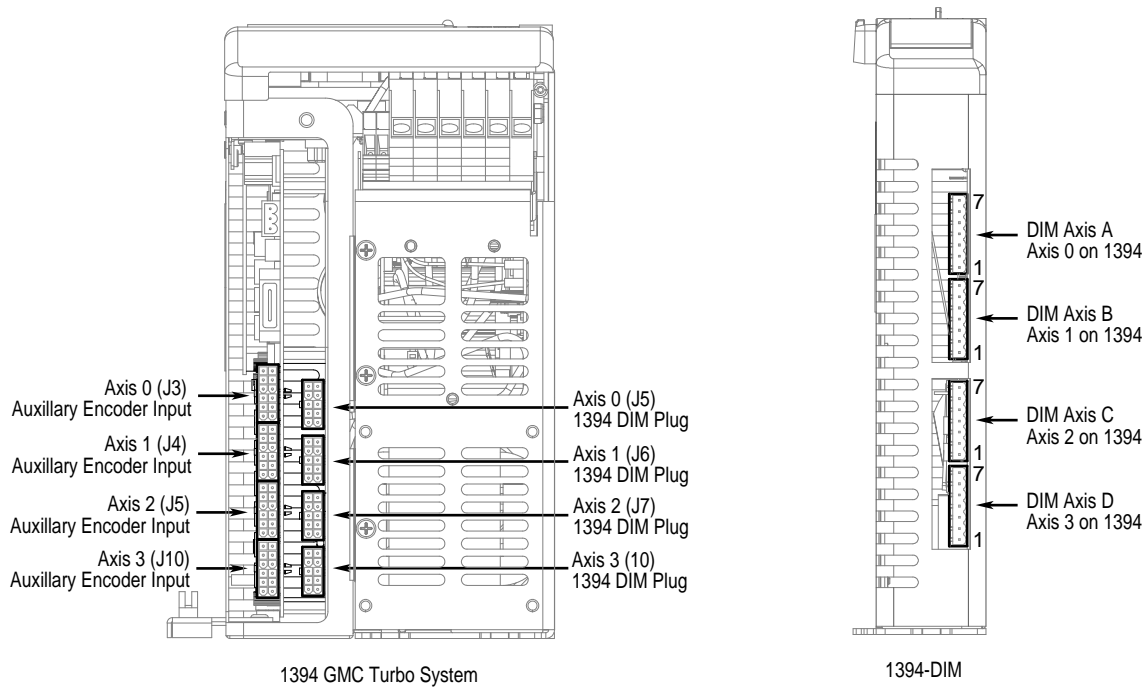

1394-System Module Input Power Wiring When Not Using Axis Modules

The figure below shows how to wire the 1394 system module for input power when no axis modules are used. The transformer is rated for 480V AC secondary and 500 VA. The fuse is a Brush (Bussmann) 600V AC, 10A (FRS-R-10A). The contactor is an Allen-Bradley Bulletin 100-C12x10 contactor.

Figure 4.25
1394 System Module Wired for Input Power Without Using Axis Modules

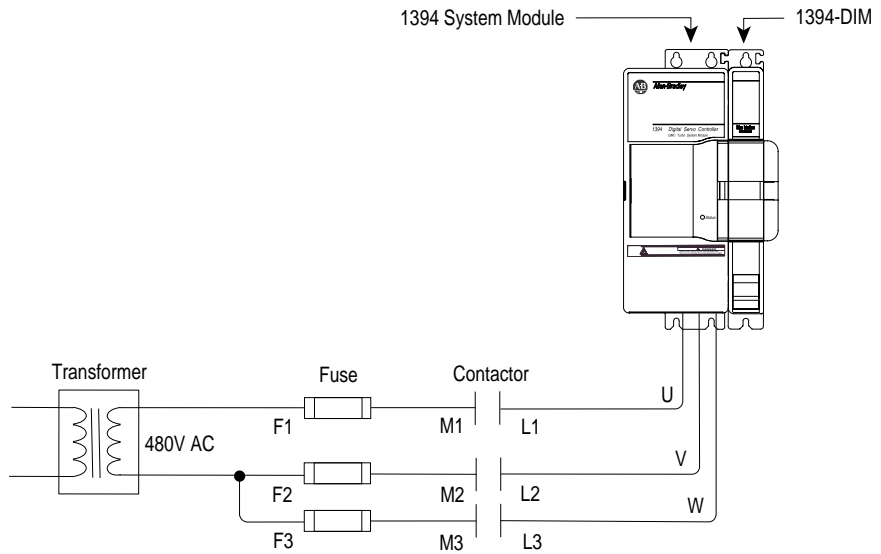

Understanding DIM Signals

DROK

The +/- DROK is a drive fault input from each external drive to the 1394-DIM. It consists of two wires connected to the external drive's DROK, an unpowered (dry) contact. The respective isolated + 15V DC for this input is supplied by the 1394-DIM.

Figure 4.26
Drive OK Input

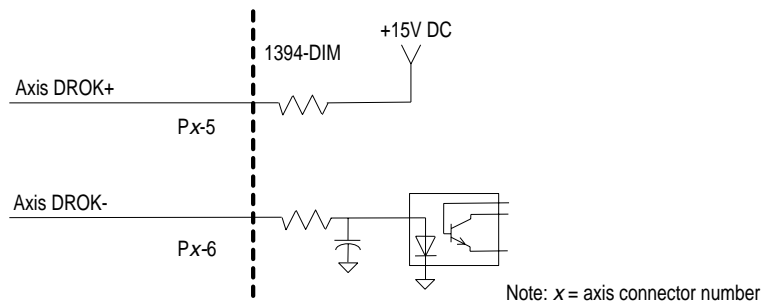

Drive Enable Output

The +/- Axis Enable is a signal from the 1394 system module that is used to control a DPDT relay in the 1394-DIM. This enable output is a normally open, unpowered (dry) signal.

Figure 4.27
Drive Enable Output

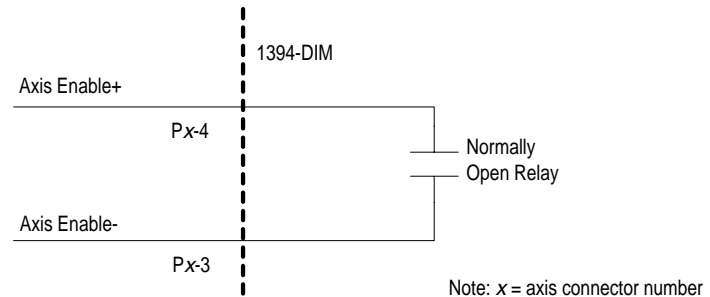

Analog Output

The analog output is an isolated signal provided by the 1394-DIM and has a range of $\pm 10V$. The signal is either a torque or velocity command, depending on the configuration of the remote drive. The command is processed by the Bulletin 1394 System Module through a 12-bit Digital-Analog Converter (DAC). An output offset of ± 80 mV can be compensated to 0V through software configuration.

Figure 4.28
Analog Output

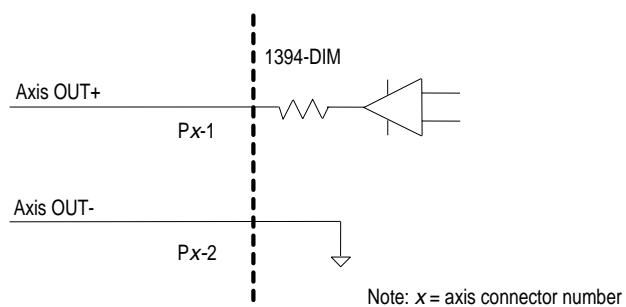

For additional DIM signal descriptions refer to *Appendix A*.

Wiring and Configuring an External Drive to the 1394-DIM

This section includes the following steps for wiring and configuring an external drive to the 1394-DIM:

- Connecting the remote drive to the DIM connector that provides the $\pm 10V$ output, the drive enable output, and the drive status input.
- Connecting the position feedback encoder to the auxiliary feedback input on the 1394 GMC/GMC Turbo System module. This provides position information for closing the position and velocity loop for the drive.
- Connecting the DIM ground wire to the 1394 system module.
- Installing the resolver feedback input plug for each DIM axis to prevent resolver loss faults.



ATTENTION: To avoid personal injury as a result of unexpected motion or acceleration of the drive, insert the resolver plug in the correct location.

Connecting the Remote Drive to the DIM Connector

The customer supplied DIM cable leads require terminating at the DIM cable connector. Follow one of the example configurations, as shown in the figure below.

Figure 4.29
DIM Connector Wiring Examples

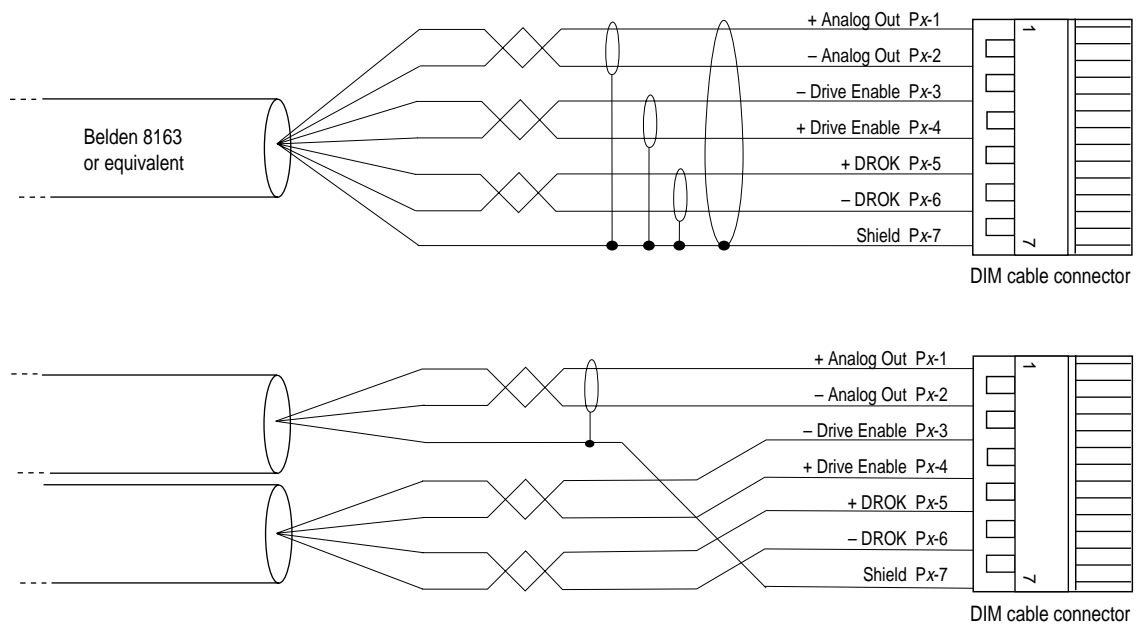

To wire the cable flying leads to the DIM cable connector:

1. Turn off the power to the system (i.e., 1394 system external drives and other control hardware).



ATTENTION: To avoid a shock hazard or personal injury, verify that all power has been removed before proceeding. This system may have multiple sources of power. More than one disconnect switch may be required to de-energize the system.



ATTENTION: To avoid hazard of electrical shock, verify that all voltage on the capacitors has been discharged before attempting to service, repair or remove this unit. This product contains stored energy devices. You should attempt the procedures in this document only if you are qualified to do so, and are familiar with solid-state control equipment and the safety procedures in publication NFPA 70E.

2. Look at the cable connector to make sure the terminal is open.
The figure below shows a terminal open and a terminal closed.

Figure 4.30
Open and Closed Terminal

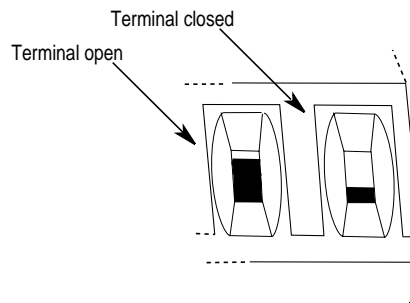

3. Using the table below, follow the correct procedure for each termination point:

If the terminal is:	Do this:
Closed	Go to step 4.
Open	Go to step 5.

4. Turn the clamping screw counter-clockwise several times with a small, flat-head screwdriver to open the termination point.

5. Strip the wire insulation back on the cable lead.

Important: Use 14-20 gauge wire to ensure proper system operation.

6. Trim the cable lead to expose 7.0 mm (0.275 in.) of metal wire.
7. Insert the cable lead in the appropriate terminal.

Figure 4.31
Cable Connector

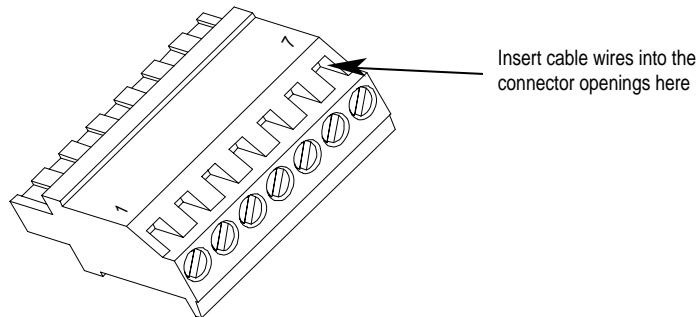

8. Use a screwdriver to tighten the clamping screw to the correct torque (0.25 N-m/2.2 lb-in.) until the cable lead cannot be pulled out of the terminal.
9. Using the table below, complete the termination connections.

If the cable lead:	Do this:
Pulls out of the terminal	Go to main step 4.
Does not pull out of the terminal	<ol style="list-style-type: none"> 1. Move to the next terminal and go to main step 2. 2. When all seven terminals are wired, go to step 10.

10. Connect each external drive to the 1394-DIM.

Important: Connect all DIM axes in succession (from the front of the unit to the back of the unit) starting with DIM Axis A regardless of the number of servo axis modules in the 1394 system.

Connecting the Position Feedback Encoder to the Feedback Input

The figure below shows the pinouts and interconnect information for the auxiliary encoder input to the 1394-GMC.

Figure 4.32
1394-GE15 Cable Connections

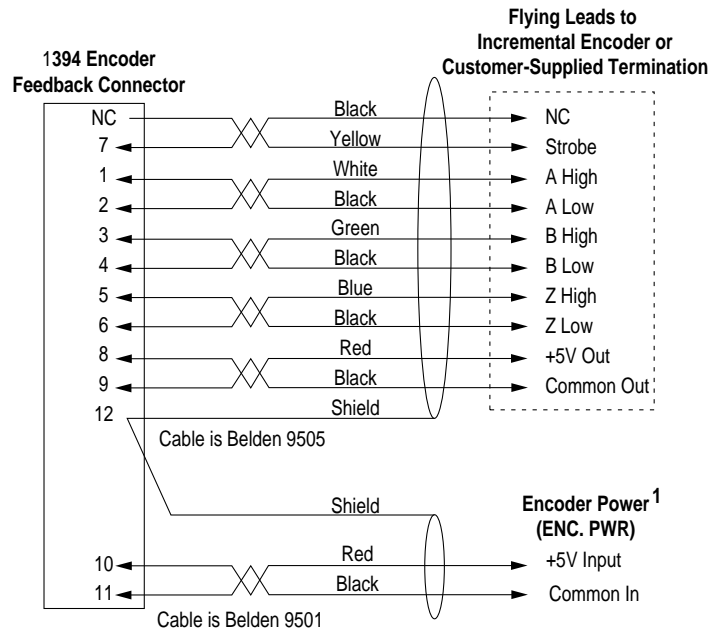

¹ Customer supplied 5V DC power source is required for encoder board whether encoder supply voltage is 5V or not.

To connect the encoder feedback cable to the 1394 system module:

1. Plug the 1394-GE15 cable for each DIM Axis into the correct auxiliary encoder input on the 1394 system module as shown in the table below. Refer to Figures 4.22, 4.23, and 4.24 for encoder input locations.

When this axis is used:	Install the Position Feedback Input plug for:			
	DIM axis A into:	DIM axis B into:	DIM axis C into:	DIM axis D into:
0 (no axis installed)	J3	J4	J5	J10
1 (axis 0 installed)	J4	J5	J10	N/A
2 (axis 0, 1 installed)	J5	J10	N/A	N/A
3 (axis 0, 1, 2 installed)	J10	N/A	N/A	N/A

Note: The other end of the 1394-GE15 cable provides flying leads and must be connected to correct signals on a quadrature encoder.

Note: The feedback inputs for axis 0, 1, 2 and 3 (on 1394x-SJTxx-C and -T systems) and for axis 0 and 1 (on 1394x-SJTxx-L systems) run from front to back (see Figure 1 in *Appendix B*).

2. Connect the cable's overall braided shield to the 1394 system ground bar.

Connecting the DIM Ground Wire to the 1394 System Ground

Connect one end of the ground wire to the connector on the 1394-DIM (refer to Figure 4.21 for location) and connect the other end to the 1394 system ground bar.

Installing the Resolver Feedback Input Plug

For each axis controlled by the 1394-DIM, insert a 1394-DIM feedback plug into the 10-pin resolver feedback input on the 1394 system module, as shown in the table below. Refer to Figures 4.22, 4.23, and 4.24 for input locations and *Appendix B* for the 1394 system module interconnect information.

When this axis is used:	Install the Resolver Feedback Input plug for:			
	DIM axis A into:	DIM axis B into:	DIM axis C into:	DIM axis D into:
0 (no axis installed)	J5	J6	J7	J10
1 (axis 0 installed)	J6	J7	J10	N/A
2 (axis 0,1 installed)	J7	J10	N/A	N/A
3 (axis 0,1,2 installed)	J10	N/A	N/A	N/A

Important: Unused DIM axis modules do not require a feedback plug to be installed.



ATTENTION: To avoid personal injury because of unexpected motion or acceleration of the drive, the resolver plug must be inserted in the correct location.

If you do not insert a 1394-DIM feedback plug into a 10-pin resolver feedback input for each DIM axis, a Resolver Loss Fault occurs for that axis if *Transducer Loss Detection* is selected in the Feedback page of the Configure Axis Use dialog box in GML Commander.

Important: 1394-DIM axes do not use the system module's thermal fault inputs. You can use these inputs for any other purpose your hardware configuration allows.

Wiring Your 1394 Analog Servo System

Chapter Objectives

This chapter covers the following topics:

- Understanding Analog Servo wiring and connections
- Understanding input wiring board layout
- Connecting AQB and SCANport cables

Finding Additional Wiring Information for 1394 Systems

This chapter provides signal wiring and connection information required for the 1394 Analog Servo system module only.

For additional wiring information on:	Refer to the following:
GMC or GMC Turbo system modules	<i>Chapter 4 (Wiring 1394 GMC and GMCTurbo Systems)</i> in this manual.
CNC Interface or 9/440 system modules	<i>9/Series CNC Hardware Integration and Maintenance Manual</i> (publication 8520-6.2).
1394 SERCOS system modules	<i>1394 SERCOS Multi-Axis Motion Control System User Manual</i> (publication 1394-5.20)

Understanding Analog Servo Wiring and Connections

The Analog Servo system module contains all of the components needed for an analog servo control system. The module provides connectors for the following:

- Motor feedback (resolver)
- AQB output and torque/velocity reference input to and from a motion controller
- Serial communications for the HIM module

Input Wiring Board Layout

The input wiring board provides terminating points at TB1 and TB2 for the various control signals. The figure below shows the locations of the various signal terminations.

Figure 5.1
Input Wiring Board (22 kW system)

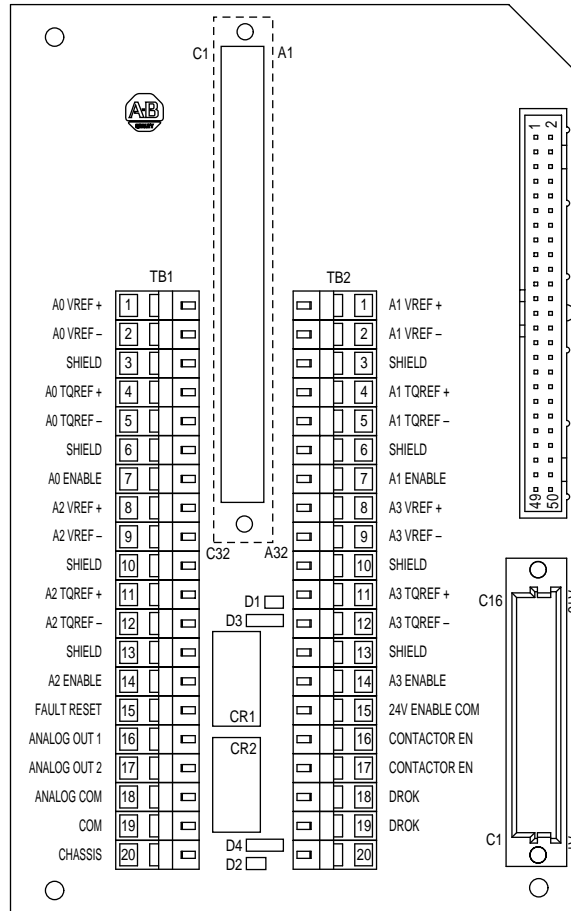

Important: Use the terminal operating tool (supplied with the system module) to help you insert and remove wires on the input wiring board.

Using the Terminal Operating Tool to Insert Wires

Each system module you order comes with a terminal operating tool that allows you to easily insert your wires into the terminals (refer to Figure 5.2). Refer to *Appendix D* for the part number.

Figure 5.2
Terminal Operating Tool

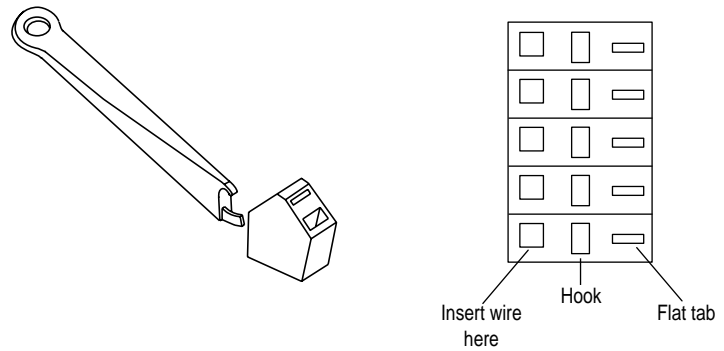

To use the terminal operating tool with TB1:

1. Put the hook into the hook slot with tab end of the tool to your left.
2. Gently push the tool to the right to open the wire slot.
3. Insert the wire.
4. Gently release the tool by moving it to the left.
5. Reverse directions for TB2.

Input Wiring Board Signal Descriptions

The tables below and on the following pages provide descriptions of the various control signals shown in Figure 5.1.

Wire:	Description:	Connects to terminal(s):	Mandatory or Optional:
A VREF + A VREF -	The drive will accept up to a +/-10V DC velocity command signal to achieve maximum motor speed. Voltages lower than +/-10V DC can be used by reprogramming (Anlg Vel Scal). You must terminate the shield at one end only. The differential impedance of the velocity command input is 80k ohms (40k ohms for single ended inputs).	TB1 and TB2 terminals 1, 2, 3, 8, 9, and 10	Optional
A TQREF + A TQREF -	The drive will accept up to a +/-10V DC torque command signal to achieve maximum torque command. Shield must be terminated at one end only. The differential impedance of the command input is 80k ohms (40k ohms for single ended inputs). 3V DC = +/- 100% rated motor current.	TB1 and TB2 terminals 4, 5, 6, 11, 12, and 13	Optional
ENABLE	Normal run commands to the drive are performed through the Enable input and any additional user-supplied run control circuitry. With 24V control power (W1, W2), three-phase input power (U, V, W), Contactor Enable (TB2-16, 17) and Drive OK (TB2-18, 19) applied, 24V DC user-supplied to this input enables the axis. When this input is de-energized, a regenerative braking action occurs on the motor.	TB1 and TB2 terminals 7 and 14 and TB2 terminal 15	Mandatory
FAULT RESET	Removing the Axis Enable signal and applying 24V DC between this terminal and signal common (TB1-19) resets the fault. Important: Do not perform a Reset until you have determined the cause of the fault and corrected it.	TB1 terminal 15	Mandatory
ANALOG OUT 1/ ANALOG COM	Motor current analog is available on TB1-16. It is scaled for 3.3V DC for 100% continuous rated motor current (10V DC = 300% motor rated current). Minimum load impedance between TB1-16 and 18 is 10K ohm. This can be linked to other parameters.	TB1 terminal 16 and 18	Optional
ANALOG OUT 2/ ANALOG COM	Motor velocity analog is available on TB1-17. It is scaled for 2.0V DC per 1000 rpm. Minimum load impedance between TB1-17 and 18 is 10K ohm. This can be linked to other parameters.	TB1 terminal 17 and 18	Optional
COM	TB1-19 must be connected to the ground bar with 3.3 mm ² (12 AWG) wire.	TB1 terminal 19	Mandatory
CHASSIS	Chassis ground reference terminal.	TB1 terminal 20	Optional
CONTACTOR EN	A set of contacts for energizing the user's three-phase line contactor coil	TB2 terminals 16 and 17	Mandatory
DROK	When you apply 24V AC/DC control power to the system and no system faults are detected, the Drive OK relay contact closes. It can also be programmed for fault only, ignoring the bus voltage. The contact remains closed until a drive fault occurs, DC bus voltage is lost, or you remove 360/480V input power from the system module depending on how you set the Drive OK mode parameter. If a drive fault is detected or the DC bus voltage is lost, the relay contact opens. You can wire the Drive OK contacts into the stop string to open the main power contactor if a fault occurs. The contact rating is 115V AC or 24V DC, 1A. DROK is located at CR2.	TB2 terminals 18 and 19	Optional

Connecting AQB and SCANport Cables

The 1394 Analog Servo system module provides connections for AQB encoder feedback outputs to external positioning controllers and SCANport. The figure below shows the locations of the AQB and SCANport connections.

Figure 5.3
Bottom View of the Analog Servo System Module

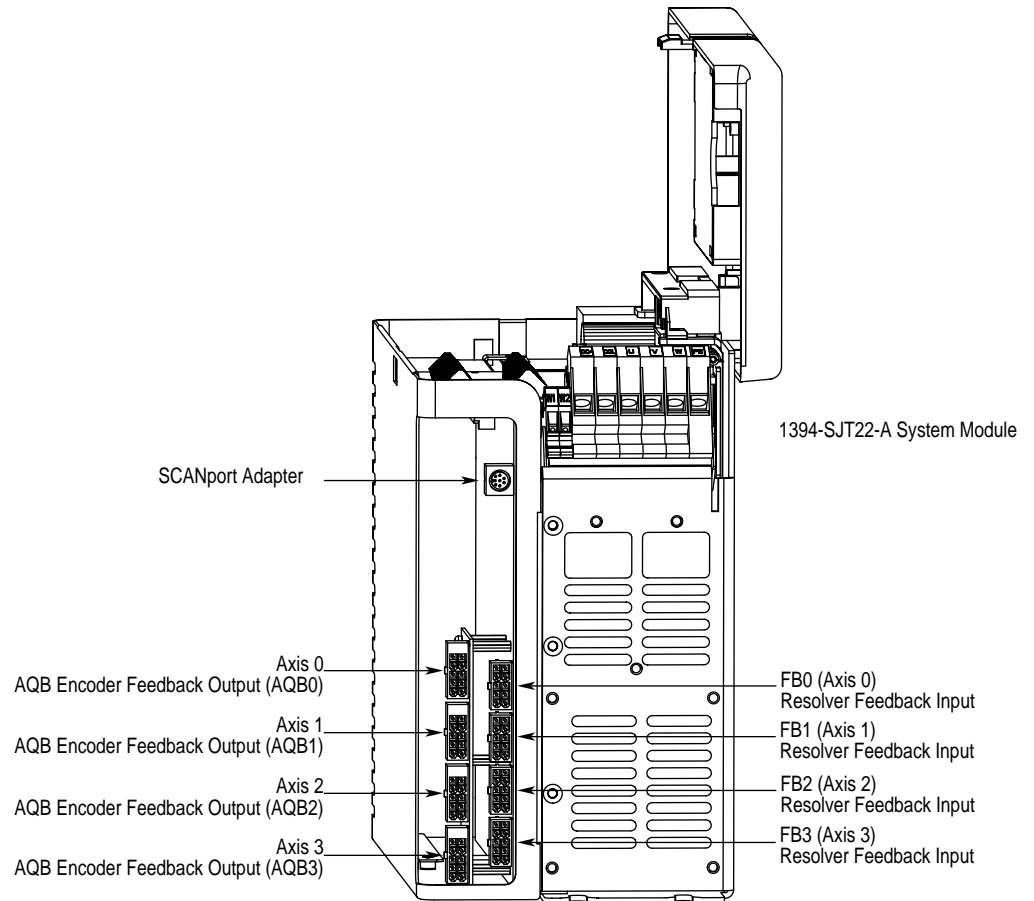

Analog Servo Encoder (A Quad B) Wiring

A Quad B uses resolver feedback to emulate an encoder differential output for motion controller position feedback. It requires a user-supplied regulated +5V DC (1 amp maximum) at terminal 3. Wiring a +5V DC power supply to one axis will provide power to all four ports (parallel connection), therefore, you only need to connect the +5V DC power supply to one AQB port. For the 1326AB series motors, the motor mechanical cycle is 2048 pulses per revolution (PPR). In addition, two marker pulses are generated per mechanical cycle. For the 1326AS series motors, the motor mechanical cycle is 1024 PPR. In addition, one marker pulse is generated per mechanical cycle. Refer to Figure 5.3 for connector locations. We recommend one 1394-SA15 (from the 1394 AQB output to the user-supplied control) cable per axis.

Make the A Quad B connections at the bottom of the system module (refer to Figure 5.3) as follows:

For this axis:	Connect to this terminal:
0	AQB0
1	AQB1
2	AQB2
3	AQB3

To improve the bond between the motor feedback cable shield and the system module PE ground, a cable shield clamp is included with the Series C system modules.

Ensure an appropriate amount of the cable insulation and braided shield is removed from the feedback cable. Place the cable wires and exposed braided shield into the cable shield clamp and tighten the clamp screw. Then thread the bracket screw into the bottom of the system module and tighten. Refer to the figure below for an illustration.

Figure 5.4
Series C System Module Cable Clamp

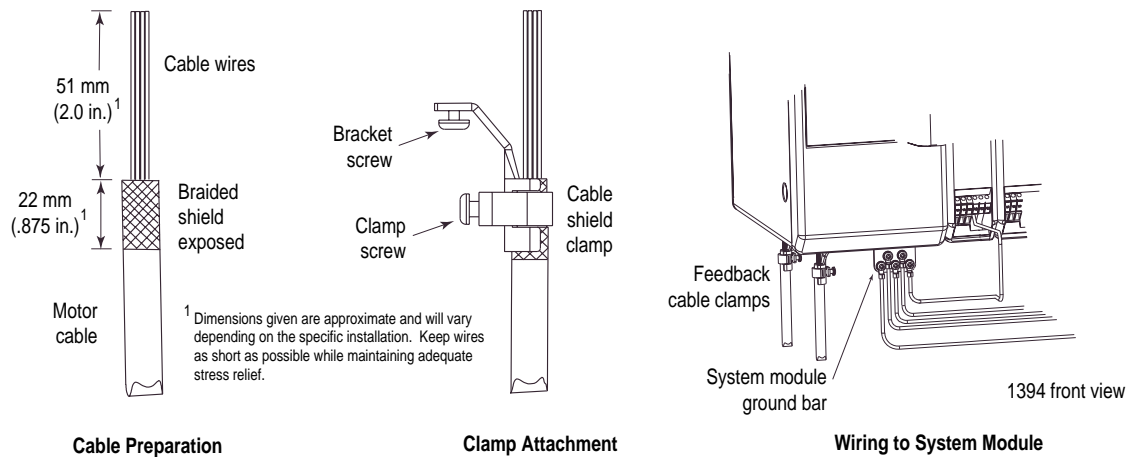

Refer to the *Appendix D* for more information about connectors and accessories and *Appendix B* for interconnect information. The table below describes each of the 12 connector pins.

Pin:	Description:
1	Axis x, Vref +
2	Axis x, Tref +
3	+5V DC Power Supply
4	Channel A High
5	Channel B High
6	Channel Z High
7	Axis x, Vref -
8	Axis x, Tref -
9	Power Supply Common
10	Channel A Low
11	Channel B Low
12	Channel Z Low



ATTENTION: To guard against possible damage to the A Quad B circuitry, assure that wiring between AQB 0, 1, 2, 3 and the position controller is correct.

Each A Quad B interface includes both a velocity (terminals 1, 7) and torque command (terminals 2, 8) input reference for direct connection to external motion controllers. These reference command inputs are in parallel to the reference inputs on the system wiring board and are provided through this port as a convenience. Do not use Axis 0, 1, 2, 3 inputs (velocity/torque) on the system wiring board if these inputs are used.

SCANport Adapter

This port allows you to connect a SCANport device, such as a Human Interface Module, to the 1394 Analog Servo System.

Commissioning 1394 GMC and GMC Turbo Systems

Chapter Objectives

This chapter provides you with the information to set up and tune the 1394 System. This chapter includes:

- General startup precautions
- Applying power to the system
- Setting up your system using GML Commander
- Setting up your system using GML 3.x.x

Before you begin the setup procedures, be sure to read and understand the information in the previous chapters of this manual.

Note: The procedures in this chapter do not include information regarding integration with other products.

General Startup Precautions

The following precautions pertain to all of the procedures in this chapter. Be sure to read and thoroughly understand them before proceeding.



ATTENTION: You need to apply power to the drive to perform many of the adjustments specified in this chapter. Voltages behind the system module front cover are at incoming line potential, voltages on the axis module front terminal block are at 360/480V AC. To avoid injury to personnel and/or damage to equipment, you should only perform these startup procedures if you are a qualified service person. Thoroughly read and understand the procedure before beginning. If an expected event does not occur while performing this procedure, do not proceed. Remove power by opening the branch circuit disconnect device and correct the malfunction before continuing.

ATTENTION: This product contains stored energy devices. To avoid hazard of electrical shock, verify that all voltages on the system bus network have been discharged before attempting to service, repair or remove this unit. Only qualified personnel familiar with solid state control equipment and safety procedures in publication NFPA 70E or applicable local codes should attempt this procedure.



ATTENTION: This drive contains ESD (Electrostatic Discharge) sensitive parts and assemblies. You are required to follow static control precautions when you install, test, service, or repair this assembly. If you do not follow ESD control procedures, components can be damaged. If you are not familiar with static control procedures, refer to Allen-Bradley publication 8000-4.5.2, Guarding Against Electrostatic Damage or any other applicable ESD Protection Handbook.

Applying Power to the System

This procedure assumes that you have wired your 1394 GMC Turbo or GMC System, verified the wiring, and are ready to download your program. To apply power to your 1394 system:

1. Verify that all 360/480V AC input power and 24V control power to the 1394 has been removed.
2. Apply 24V control power to the system module. The Status LEDs on the axis modules flash red and green and the Status LED on the system module illuminates. This indicates that the control logic is ready, but the power bus is not active.
3. Verify that the control power voltage at the input terminals of the System Module is 24V AC (or 24V DC) $\pm 10\%$.

4.

If the system module LED:	Then:
Flashes red and green	Go to step 5.
Flashes green, flashes red, or remains solid red	You may have a wiring problem. Go to the <i>Troubleshooting</i> chapter.
Does not illuminate	<ol style="list-style-type: none"> 1. Verify line and 24V control power. 2. Go to main step 1.

5. Apply 360/480V AC input power.
6. Verify that the 360/480V AC input voltage is present at the input terminals of the system module or at the user-supplied input contactor.

7.

If the system module LED:	Then:
Flashes green	The control and bus power are active, but the modules are not enabled. Go to step 8.
Flashes red and green, flashes red, or remains solid red	You may have a wiring problem. Go to the <i>Troubleshooting</i> chapter.
Does not illuminate	

8. Apply 24V DC to the system enable (TB1-1, -2 or TB2-1, -2 on the input wiring board) to enable the system module. The system module's Status LED should be solid green.

When you apply power to the motion controller, the hardware and software are initialized. Refer to the *GML Commander Reference Manual* (publication GMLC-5.2) or *GML 3.x User Manual* (publication 999-104) for a listing of the initialized values.

Setting Up Your System Using GML Commander

This section provides the information you need to setup and tune your 1394 GMC and GMC Turbo system using GML Commander.

Before You Begin

Before you begin the setup procedure be sure to have the following:

- A computer running Windows 95 and GML Commander
Note: 1394C-SJTxx-L system modules require GML Commander 4.03 or later.
- A nine-pin serial cable to connect the computer to the 1394 serial port
- *GML Commander Reference Manual* (publication GMLC-5.2)
- A voltmeter
- A standard screwdriver

Preparing the System

Before you start your 1394 system be aware of the following:

To:	Do this:
Be able to save setup menus	Set the <i>Memory</i> keyswitch to the unlock position.
Set the remote node if you are using AxisLink or multi-drop functions	Use the <i>Address</i> switch to set a unique address for each 1394 connected. The addresses can be set in any order. Refer to Figure 4.6 in the <i>Wiring GMC and GMC Turbo Systems</i> chapter for the switch's location.
Reset critical drive parameters to their factory default value if the 1394 does not communicate properly during power-up	Hold down the <i>Init</i> switch while you power up the system.
Reset the system	Press the <i>Reset</i> switch.

For specific set up instructions using GML Commander, refer to the following sections of your GML Commander Reference Manual.

To:	Refer to the:	In this manual:	Publication Number:
Understand the setup process	<i>Configuring Control Options</i> chapter	<i>GML Commander Reference Manual</i>	GMLC-5.2
Define your user interface	<i>Configuring Control Options</i> chapter		
Define your control options, axes, and Flex I/O	<i>Configuring Control Options</i> chapter		
Setup RIO, SLC Interface, AxisLink, and DH-485	<i>Configuring Control Options</i> chapter		
Establish communications with the 1394	<i>Accessing your Controller</i> section of the <i>Going Online</i> chapter		
Download your GML diagram to the 1394	<i>Translating a Diagram to a Program and Downloading</i> section of the <i>Going Online</i> chapter		
Test your motor connections (motor encoder and marker tests)	<i>Verifying Hookups</i> section of the <i>Configuring Axis Use</i> chapter		
Tune your 1394 axes	<i>Tune Servo</i> section of the <i>Configuring Axis Use</i> chapter		
Apply the changes you made	<i>Applying Axis Configuration Changes</i> section of the <i>Configuring Axis Use</i> chapter		

Setting Up Your System Using GML 3.x.x

This section provides the information you need to setup and tune your 1394 GMC and GMC Turbo using GML version 3.x.x.

Before You Begin

Before you begin the startup procedure be sure to have the following:

- A computer running Windows and GML , version 3.9.0 or later
- A nine-pin serial cable to connect the computer to the 1394 serial port
- A GML Programming Manual (publication 999-104)
- A voltmeter
- A standard screwdriver

Preparing the System

Before you start your system, be aware of the following:

To:	Do this:
Be able to save setup menus	Set the <i>Memory</i> keyswitch to the unlock position.
Set the remote node if you are using AxisLink or multi-drop functions	Use the <i>Address</i> switch to set a unique address for each 1394 connected. The addresses can be set in any order. Refer to Figure 4.6 in the <i>Wiring 1394 GMC and GMCTurbo Systems</i> chapter for location.
Reset critical drive parameters to their factory default value if the 1394 does not communicate properly during power-up	Hold down the <i>Init</i> switch while you power up the system.
Reset the system	Press the <i>Reset</i> switch or use the 1394 reset object in GML (GMC version only).

For specific set up instructions using GML 3.x.x, refer to your GML Programming Manual (publication 999-104).

Commissioning Your 1394 Analog Servo System

Chapter Objectives

This chapter provides you with the information to set up and tune your 1394 Analog Servo System. This chapter includes:

- General startup precautions
- Setting up your 1394 Analog Servo system

Before you begin the setup procedures, be sure to read and understand the information in the previous chapters of this manual.

Note: The procedures in this chapter do not include information regarding integration with other products.

General Startup Precautions

The following precautions pertain to all of the procedures in this chapter. Be sure to read and thoroughly understand them before proceeding.



ATTENTION: You need to apply power to the drive to perform many of the adjustments specified in this chapter. Voltages behind the system module front cover are at incoming line potential, voltages on the axis module front terminal block are at 360/480V AC. To avoid injury to personnel and/or damage to equipment, you should only perform these startup procedures if you are a qualified service person. Thoroughly read and understand the procedure before beginning. If an expected event does not occur while performing this procedure, do not proceed. Remove power by opening the branch circuit disconnect device and correct the malfunction before continuing.

ATTENTION: This product contains stored energy devices. To avoid hazard of electrical shock, verify that all voltages on the system bus network have been discharged before attempting to service, repair or remove this unit. Only qualified personnel familiar with solid state control equipment and safety procedures in publication NFPA 70E or applicable local codes should attempt this procedure.



ATTENTION: This drive contains ESD (Electrostatic Discharge) sensitive parts and assemblies. You are required to follow static control precautions when you install, test, service, or repair this assembly. If you do not follow ESD control procedures, components can be damaged. If you are not familiar with static control procedures, refer to Allen-Bradley publication 8000-4.5.2, *Guarding Against Electrostatic Damage* or any other applicable ESD Protection Handbook.

Setting Up Your 1394 Analog Servo System

This section provides the following to help you set up and tune the 1394 Analog Servo System:

- Information you need before you begin
- Setup procedures
- The instructions in this chapter assume that you are using a HIM Series A 3.0 or greater or a HIM Series B. Refer to *Appendix C* for general HIM programming information. To determine the series of your module, refer to Figure P.1 in the *Preface*.

In most cases, the default values in the startup procedure will work very well, however, you can modify the values, as needed, for your application.

During the startup procedures, the system automatically saves all the choices that you make to EEPROM as you complete each step.

Before You Begin

Before you begin the startup procedure, verify that the system has been wired correctly and be sure to have a voltmeter.

Exiting Before You're Finished

If you need to exit the procedures before you are finished, you can do one of two things:

- Remove and re-apply power.
- Press ESC until the Choose Mode display appears.

Continuing From Where You Left Off

To continue the procedure:

1. At the HIM, press **ENTER**. The following message appears:

```
Choose Mode
Start Up
```

2. Press **ENTER**. The following appears:

```
Start Up
Continue
```

- 3.

To:	Do this:
Continue from where you left off	Press ENTER . The display at which you left off appears.
Start over from the beginning	<ol style="list-style-type: none"> 1. Press either the up or down arrow key until <i>Reset Sequence</i> appears. 2. Press ENTER. The display at which you left off appears.

Removing and Re-Applying Power

This procedure assumes that you have wired your 1394 Analog Servo System and verified the wiring.

1. Remove all 360/480V AC input power and 24V control power to the 1394.
2. Apply 24V control power. The LEDs on the system and axis modules flash red and green. In addition, the HIM becomes active and a message similar to the following appears:

```
Sys Wait Bus
0
```

Note: When you apply power to the HIM, a series of messages appear before the final *Sys Wait Bus* or message appears.

3. Verify that the voltage at the input terminals of the System Module is 24V AC (or 24V DC) $\pm 10\%$.
- 4.

If the system module LED:	Then:
Flashes red and green and the following appears on the HIM: Sys Wait Bus	Go to step 5.
Flashes red, remains solid red, or does not illuminate	You may have a wiring or power problem. Go to the <i>Troubleshooting</i> chapter.

5. Apply 360/480V AC input power. The system and axis module LEDs flash green and the following appears on the HIM:

```
Sys Ready
```

6. Verify that the 360/480V AC input voltage is present at the input terminals or at the user-supplied input contactor.

7.

If the system module LED:	Then:
Flashes green and the following appears on the HIM: Sys Ready	The control and bus power are active, but the modules are not enabled. Go to <i>Setting Up at the System Level</i> .
Flashes red and green, flashes red, remains solid red, does not illuminate	You may have a wiring problem. Go to the <i>Troubleshooting</i> chapter.

Setting Up at the System Level

This procedure assumes that you have wired your 1394 Analog Servo System and have completed the procedure *Removing and Re-Applying Power* earlier in this chapter.

When the LEDs on the system and axis modules are all flashing green and the Sys Ready message appears on the HIM, you are ready to begin these procedures.

To perform system-level setup:

1. At the HIM, press **ENTER**. A message similar to the following appears:

```
Choose Mode
Display
```

2. Press either the up or down arrow key until the following appears:

```
Choose Mode
Start Up
```

3. Press **ENTER**. The following message appears:

```
ALLEN-BRADLEY
COPYRIGHT 1994
```

4. Press **ENTER**. A message similar to the following appears:

```
Line Voltage
460 Volts AC
```

5. Press **SEL**. The cursor moves to the bottom line.

6.

If you are using:	Do this:
480 V AC	Press ENTER . The system records your choice.
360 V AC	<ol style="list-style-type: none"> 1. Press either the up or down arrow key until 360 Volts AC appears. 2. Press ENTER. The system records your choice.

7. Press **ENTER**. A message similar to the following appears:

```
Disp-D/A Monitor  
Not Linked
```

8. Go to *Setting Up Analog Test Points*.

Setting Up Analog Test Points

The 1394 startup procedures provide the ability to monitor an axis using analog test points.

Important: When you set up test points and auto tune, you will always set up one complete axis and tune it before you begin another.

This procedure assumes that you have wired your 1394 Analog Servo System and have completed the procedures in the following sections of this chapter:

- Removing and Re-Applying Power
- Setting Up at the System Level

To set up your system so that you can monitor an axis using analog test points:

1. When the *Disp-D/A Monitor* message appears, press **SEL**. The cursor moves to the bottom line.
2. Press either the up or down arrow key until the axis that you want to configure appears.
3. Press **ENTER**. The system records your choice and the cursor moves to the top.
4. Press **ENTER**. A message similar to the following appears:

```
Ax:Motor Type  
Custom Motor
```

5. Go to *Defining Your Motor*.

Defining Your Motor

This procedure assumes that you have wired your 1394 Analog Servo System and have completed the procedures in the following sections of this chapter:

- Removing and Re-Applying Power
- Setting Up at the System Level
- Setting Up Analog Test Points

To define your motors:

1. When the *Ax:Motor Type* message appears, press **SEL**. The cursor moves to the bottom line.

2.

To define:	Do this:
A standard motor	Go to step 3.
A custom motor	1. Select Custom . 2. Enter the appropriate information for your motor. 3. Go to step 6. Note: Use only custom motor parameters supplied by Allen-Bradley.

3. Press either the up or down arrow key until the base catalog number of the motor you will use for this axis appears.
4. Press **ENTER**. The system records your choice and the cursor moves to the top line.
5. Press **ENTER**. A message similar to the following appears:

```
Ax:Mode Sel
Anlg Vel
```

6. Go to *Defining a Reference Source for Your Axes*.

Defining a Reference Source for Your Axes

This procedure assumes that you have wired your 1394 Analog Servo System and have completed the procedures in the following sections of this chapter:

- Removing and Re-Applying Power
- Setting Up at the System Level
- Setting Up Analog Test Points
- Defining Your Motors

To define a reference for your axes:

1. When the *Ax:Mode Sel* message appears, press **SEL**. The cursor moves to the bottom line.

2.

If the axis will get its reference from:	Press either the up or down arrow until this appears:
Analog velocity	Anlg Vel
Analog torque	Ana Torq
Digital velocity from SCANport	Dig Vel
Digital torque from SCANport	Dig Torq

3. Press **ENTER**. The cursor moves to the top line.

4.

If you selected:	Go to:
Anlg Vel	<i>Defining Analog Velocity.</i>
Ana Torq	<i>Defining Analog Torque.</i>
Dig Vel	<i>Defining Digital Velocity.</i>
Dig Torq	<i>Defining Digital Torque.</i>

Defining Analog Velocity

This procedure assumes that you have wired your 1394 Analog Servo System and have completed the procedures in the following sections of this chapter:

- Removing and Re-Applying Power
- Setting Up at the System Level
- Setting Up Analog Test Points
- Defining Your Motors

These procedures continue from step 4 of *Defining a Reference Source for Your Axes*.

To define analog velocity:

1. When the *Ax:Mode Sel Anlg Vel* message appears, press ENTER. A message similar to the following appears:

```
Ax:Anlg Vel Scal
+500.0 rpm/v
```

2. Press **SEL**. The cursor moves to the bottom line.
3. Press either the up or down arrow until the parameter number that you want to use for the rpm/volt gain appears.
4. Press **ENTER**. The system records your choice and the cursor moves to the top line.
5. Press **ENTER**. A message similar to the following appears:

```
Short Ax:Vel In
Before Proceed
```

6. On the system module's input board, short the velocity reference inputs (AxVref+ and AxVref-) to null the analog velocity offset.
7. Press **ENTER**. A message similar to the following appears:

```
Ax:Current Limit
+8.43 amps
```

8. Remove the short on the velocity reference inputs.
9. Go to *Defining Limits*.

Defining Analog Torque

This procedure assumes that you have wired your 1394 Analog Servo System and have completed the procedures in the following sections of this chapter:

- Removing and Re-Applying Power
- Setting Up at the System Level
- Setting Up Analog Test Points
- Defining Your Motors

These procedures continue from step 4 of *Defining a Reference Source for Your Axes*.

To define analog torque:

1. When the *Ax:Mode Sel Ana Torq* message appears, press **ENTER**. A message similar to the following appears:

```
Ax:Current Limit
+8.43 amps
```

2. Go to *Defining Limits*.

Defining Digital Velocity

This procedure assumes that you have wired your 1394 Analog Servo System and have completed the procedures in the following sections of this chapter:

- Removing and Re-Applying Power
- Setting Up at the System Level
- Setting Up Analog Test Points
- Defining Your Motors

These procedures continue from step 4 of *Defining a Reference for Your Axes*.

To define digital velocity:

1. When the *Ax:Mode Sel Dig Vel* message appears, press **ENTER**. A message similar to the following appears:

```
Ax:Vel Ref Whole
<204 > <---352
```

Note: The number on the left is the destination, while the number on the right is the source.

2. Press **SEL**. The cursor moves to the bottom line.
3. Press either the up or down arrow until the parameter number that you want to use for your digital velocity appears.

4. Press **ENTER**. The system records your choice and the cursor moves to the top line.
5. Press **ENTER**. A message similar to the following appears:

```
Ax:Current Limit
+8.43 amps
```

6. Go to *Defining Limits*.

Defining Digital Torque

This procedure assumes that you have wired your 1394 Analog Servo System and have completed the procedures in the following sections of this chapter:

- Removing and Re-Applying Power
- Setting Up at the System Level
- Setting Up Analog Test Points
- Defining Your Motors

These procedures continue from step 4 of *Defining a Reference for Your Axes*.

To define digital torque:

1. When the *Ax:Mode Sel Dig Torq* message appears, press **ENTER**. A message similar to the following appears:

```
Ax:Dig Torq Ref
<212> <---356
```

Note: The number on the left is the destination, while the number on the right is the source.

2. Press **SEL**. The cursor moves to the bottom line.
3. Press either the up or down arrow until the parameter you want to use for you digital torque appears.
4. Press **ENTER**. The system records your choice and the cursor moves to the top line.
5. Press **ENTER**. A message similar to the following appears:

```
Ax:Current Limit
+8.43 amps
```

6. Go to *Defining Limits*.

Defining Limits

This procedure assumes that you have wired your 1394 Analog Servo System and have completed the procedures in the following sections of this chapter:

- Removing and Re-Applying Power
- Setting Up at the System Level
- Setting Up Analog Test Points
- Defining Your Motors
- Defining a Reference Source for Your Axes

To define limits:

1. When the *Ax: Current Limit* message appears, press **SEL**. The cursor moves to the bottom line.
2. Press either the up or down arrow until the appropriate current limit appears.
3. Default values are set by the motor type you selected. You cannot exceed this value.
4. Press **ENTER**. The system records your choice and the cursor moves to the top line.
5. Press **ENTER**. A message similar to the following appears:

```
Ax:Vel Lim  
5000.0 rpm
```

Note: Default values are set by the motor type you selected. You cannot exceed this value.

6. Press **SEL**. The cursor moves to the bottom line.
7. Press either the up or down arrow until the appropriate velocity limit appears.
8. Press **ENTER**. The system records your choice and the cursor moves to the top line.
9. Press **ENTER**. A message similar to the following appears:

```
Ax:ATune Select  
Idle
```

10. Go to *Auto Tuning*.

Auto Tuning

This procedure assumes that you have wired your 1394 Analog Servo System and have completed the procedures in the following sections of this chapter:

- Removing and Re-Applying Power
- Setting Up at the System Level
- Setting Up Analog Test Points
- Defining Analog Velocity
- Defining a Reference Source for Your Axes
- Defining Limits

Before You Perform an Auto Tune

Before you perform an auto tune, look at the status LED on the system module.

If the Status LED on the System Module is:	Do this:
Flashing green	Go to <i>Performing the Auto Tune</i> .
Alternating red and green	1. Apply 360/480V AC line voltage. 2. Go to <i>Performing the Auto Tune</i> .
Flashing red	1. Clear the fault. 2. Apply 360/480V AC line voltage. 3. Go to <i>Performing the Auto Tune</i> .
Solid green	1. Disable the axis that is currently enabled. 2. Go to <i>Performing the Auto Tune</i> .
Solid red	A hardware fault has occurred. Refer to the <i>Troubleshooting</i> chapter for more information.

Performing the Auto Tune

To auto tune your axes:

1. When the *Ax:ATune Select Idle* message appears, press **SEL**. The cursor moves to the bottom line.
2. Press either the up or down arrow until *Axis Tune* appears on the bottom line.
3. Press **ENTER**. A message similar to the following appears:

```
Ax:ATune Select
Enable Axis
```

Note: If the message is Not Ready, refer to the beginning of this *Auto Tuning* section for information.



ATTENTION: When you auto tune an axis, the motor will move slightly.

- Apply 24V DC across the appropriate axes on the input wiring board to enable the axis that you are tuning. The LEDs on system module and specific axis module will be solid green, the motor will move slightly and the following messages appear sequentially on the HIM:

```
Ax:ATune Select
Wait, Tuning
```

```
Ax:ATune Select
Disable Axis
```

- Disable the axis. Messages similar to the following appear:

```
Ax:ATune Select
Opr Complete
```

```
Ax:ATune Select
Idle
```

Note: If you do not disable the axis, the system does it for you, however, you still need to manually disable it before you proceed.

- Press **ENTER**. A message similar to the following appears showing the next axis:

```
Ax:Motor Type
1326AB-B410G
```

-

If you have:	Then:
More axes to set up and tune	Go to <i>Defining Your Motor</i> .
Set up and tuned all axes	Press ESC until the Choose Mode message appears. You are finished with the setup procedures.

Configuring Your 1394 Analog Servo System

Chapter Objectives

This chapter covers the following topics:

- Where to look for other programming information.
- Conventions used in this chapter.
- Understanding Analog Servo System parameters.
- 1394 Analog Servo software diagram

Because GML and the HIM provide auto tune and setup features, the information in this chapter is intended only a supplement to help you to understand the technical approach and to assist you with using communication tools, such as SCANport.

Where to Look for Other Programming Information

System configuration information for other 1394 systems are given in the table below.

For:	Refer to:
GMC or GMC Turbo system configuration	<i>GML Programming Manual</i> (publication 999-104).
CNC Interface or 9/440 system configuration	<i>9/Series CNC AMP Reference Manual</i> (publication 8520-ARM2).
1394 SERCOS system modules	<i>ControlLogix Motion Module Setup and Configuration Manual</i> (publication 1756-UM006A-EN-P).

Conventions Used in this Chapter

The following conventions are used throughout this chapter.

- All parameters required for any given drive function are contained within a group, eliminating the need to change groups to complete a function.
- Each parameter will contain the following:

Parameter:	Description:
Name	The actual parameter name as displayed on the HIM (or ODS software). Parameter names appear within brackets, for example: [100% Torq Vel].
Description	An explanation of the parameter and, when feasible, an application example.
Number	Each parameter is assigned a number that can be used for serial communication. The numbers are listed in order for Axis 0, 1, 2, 3.
Group	Most parameters are contained in a group to make programming easier.
Display Units	<ul style="list-style-type: none"> • ENUMS - A language statement pertaining to the selection made. • Engineering - Standard display units such as; Hz, sec, volts, etc. • Drive Units - These are internal Display Units used to communicate through the serial port, and to scale values properly when reading or writing to the drive.
Type	<ul style="list-style-type: none"> • Read Only - The value is changed only by the drive and is used to monitor values. • Read/Write - The value is changed through programming. This type can also be used to monitor a value.
Change While Running	States whether the parameter can be changed while the drive is running.
Linkable	States whether the parameter can be linked.
Minimum Value	This is the lowest setting possible for parameters.
Maximum Value	This is the highest setting possible for parameters.
Default Value	This is the value assigned to each parameter at the factory. It is also the value that will be restored if you choose to restore defaults from the HIM. Display text appears within quotation marks.
Selections	Predefined functions. Display text appears within quotation marks.

Note: To determine the series of your module, refer to Figure P.1 in the *Preface*.

Understanding Analog Servo System Parameters

A description of the 1394 Analog Servo parameters is provided on the following pages. The parameters are listed in alphabetical order and cross-referenced in the table that follows for locating parameters by number.

<u>Parameter</u>	<u>Parameter Name</u>	<u>Parameter</u>	<u>Parameter Name</u>	<u>Parameter</u>	<u>Parameter Name</u>
1	Software Version	58-69	Rem. Data In/Out:Px	228-231	Cur Lim Cause
2	Units Sel	70-85	Rem. Data In/Out:Ax	232-235	Iq Cur Ref
3	Startup State	90	Pwr On Minutes	236-239	Id Cur Ref
4	Language Sel	91	Pwr On Days	240-243	Stop Mode
5	Slot 0 Opt Card	92	Enabled Minutes	244-247	Resolvr Turns
6	Sys Mod Data	93	Enabled Days	248-251	Up To Spd Tol
7	Sys I/O Image	94	Sum On Minutes	252-255	Desired BW
8	Status Display	95	Sum On Days	256-259	Vel Damp Sel
9	Line Voltage	100-103	Motor Type	260-263	Bridge Lim
10, 11	D/A Gain	104-107	Mtr Rated Cur	264-267	Cur Fbk Scale
12, 13	D/A Value	108-111	Mtr Inertia	268-271	Cur Fbk Rated
14	System Type	112-115	Mode Sel	272-275	Anlg Vel Scal
16	Test Mode Sel	116-119	Current Limit	276-279	Anlg Vel Ofst
17	Type 1 Status	120-123	Vel Lim	284-287	ATune Vel
18	Type 2 Status	124-127	Mtr Peak Cur	288-291	ATune Current
19	Drive OK Mode	128-131	CW Vel Lim	292-295	ATune Inertia
20	Disp-D/A Monitor	132-135	CCW Vel Lim	296-299	ATune Select
21	Command Mask	136-139	Vel Rate Lim	300-303	ATune Frictn
22	Dig Cmd Mode	140-143	Vel LowPas BW	304-307	Max Bandwidth
23	Typ 1 Logic Axis	144-147	Ld/Lg Degrees	308-311	Stopping Cur
24	Enble Input Mode	148-151	Ld/Lg Freq	324-327	Module Size
25	Hardware Version	152-155	CW OvSpd Vel	328-331	Axis Type
30, 32, 34, 36	Option x Code	156-159	CCW OvSpd Vel	344-347	I(t) Cur Lim
31, 33, 35, 37	Option x Status	164-167	Cur Preload	348-351	Jog Vel
38	Sys Mod Status 2	172-175	Id RPM Start	352-355	Int Vel Ref
39	Bus Voltage	176-179	Id RPM End	356-359	Int Torq Ref
40	Rg Power Usage	180-183	Id Slope	360-363	Torq Source
41	Mt Power Usage	184-187	Pos Cur Lim	364-367	Vel Source
42	Shunt Usage	188-191	Neg Cur Lim	368-371	Prop Gain Kp
43	Shunt Type	192-195	Cur Rate Lim	372-375	Intg Gain Ki
44	Shunt R	196-199	Mod Rng Data	376-379	Feed Fwd Gain
45	Shunt P	200-203	State	380-383	Droop
46	Shunt Ks	204-207	Vel Ref Whole	384-387	Stop Time Lim
47	Shunt KI	208-211	Vel Ref Fract	388-391	300% Torq Vel
48	Shunt Ws	212-215	Dig Torq Ref	392-395	100% Torq Vel
49	Shunt Type	216-219	Resolvr Posn	396-399	Mtr Pole Cnt
50	DC Link Setup	220-223	Vel Command	400-403	Fdbk Pole Cnt
51	Shunt Peak Usage	224-227	Vel Feedback	404-407	Motor Type

<p>[100% Torq Vel] Motor velocity at 100% rated motor torque.</p> <p>Note: Before making modifications to Mtr Data parameters, [Motor Type] must be set to "custom motor".</p>	<p>Parameter Numbers 392 Parameter Group Mtr Data Display Units rpm Parameter Type Read/Write Change While Running Yes Linkable No Minimum Value 1 rpm Maximum Value 8000 rpm Default Value This is determined by the motor catalog number.</p>
<p>[300% Torq Vel] Motor velocity at 300% rated motor torque.</p> <p>Note: Before making modifications to Mtr Data parameters, [Motor Type] must be set to "custom motor".</p>	<p>Parameter Numbers 388 Parameter Group Mtr Data Display Units rpm Parameter Type Read/Write Change While Running Yes Linkable No Minimum Value 1 rpm Maximum Value 8000 rpm Default Value This is determined by the motor catalog number.</p>
<p>[Anlg Vel Ofst] An offset value that can be used on an analog velocity input to counter voltage offsets on that input. This value is added after the input scaling has taken place, therefore changing the analog input scaling will change this offset compensation.</p>	<p>Parameter Numbers 276, 277, 278, 279 Parameter Group Vel Cmd Data Display Units rpm Parameter Type Read/Write Change While Running Yes Linkable No Minimum Value- 496.00 rpm Maximum Value+ 496.00 rpm Default Value 0.00 rpm</p>
<p>[Anlg Vel Scal] Use this parameter to determine how the A/D converter value is scaled. It is set to the number of motor rpm that is to represent 1 volt of input command. The desired input velocity command voltage to motor rpm scaling is accomplished with this parameter. The default setting is 500 rpm/volt. Use the following formula if the maximum motor speed (rpm) and maximum velocity command (volts) are known.</p>	<p>Parameter Numbers 272, 273, 274, 275 Parameter Group Vel Cmd Data Display Units rpm/v Parameter Type Read/Write Change While Running Yes Linkable No Minimum Value- 1000.0 rpm/v Maximum Value +1000.0rpm/v Default Value +500.0 rpm/v</p> <p style="text-align: right;"><i>for example:</i></p> $\frac{\text{MaximumDesiredMotorRPM}}{\text{MaximumVelocityCommand}} = \frac{\text{RPM}}{\text{Volts}} = \frac{3000\text{RPMMaximum}}{8\text{VDCMaximumCommand}} = \frac{3000\text{RPM}}{\text{Volts}}$
<p>[ATune Current] The motor current used while an auto tune cycle is executing is specified with this parameter. In most cases, the default setting will be satisfactory.</p>	<p>Parameter Numbers 288, 289, 290, 291 Parameter Group ATune Config Display Units amps Parameter Type Read/Write Change While Running Yes Linkable No Minimum Value 10% rated motor current Maximum Value 200% rated motor current Default Value 50% rated motor current</p>

<p>[ATune Frictn] The system friction as measured by the auto tune cycle is represented through this parameter.</p>	<p>Parameter Numbers 300, 301, 302, 303 Parameter Group ATune Config Display Units % Parameter Type Read/Write Change While Running Yes Linkable No Minimum Value 0% Maximum Value 12% Default Value 6%</p>									
<p>[ATune Inertia] System inertia as measured by auto tuning. This parameter is calculated during auto tune and is the time that the motor and load takes to reach [ATune Vel] at [ATune Current] and back to zero rpm. This needs no manual user adjustment, since it is a product of the auto tune function. To determine the inertia of the machine system, use the following formula:</p>	<p>Parameter Numbers 292, 293, 294, 295 Parameter Group ATune Config Display Units msec Parameter Type Read/Write Change While Running Yes Linkable No Minimum Value 0 msec Maximum Value 10000 msec Default Value 5 msec</p> $J_{\text{system}} = \frac{[\text{AutoTuneInertia}]}{[\text{MtrlInertia}] * 0.83} * \text{Rotor}_{\text{inertia}}$ <p>Note: The value for rotor inertia (lb-in.-s²) is listed on the servo motor performance data table in <i>Appendix A</i>.</p>									
<p>[ATune Select] This parameter initiates an auto tune cycle that measures the [ATune Inertia] and [ATune Frictn] by accelerating the motor up to the [ATune Vel] at the [ATune Current]. The parameter also calculates the gains based on auto tune information.</p>	<p>Parameter Numbers 296, 297, 298, 299 Parameter Group ATune Config, Startup Parm Parameter Type Read/Write Change While Running Yes Linkable No Default Value 0 "idle"</p> <p>Selections</p> <table border="0"> <tr> <td style="padding-right: 20px;">0</td> <td style="padding-right: 20px;">"Idle"</td> <td>Indicates the auto tune system can be used, written command forces the system to idle.</td> </tr> <tr> <td>1</td> <td>"Axis Tune"</td> <td>Written as a command, initiates the auto tune process, messages will be displayed to enable axis, wait, disable axis. "Calculate" is also performed.</td> </tr> <tr> <td>2</td> <td>"Calculate"</td> <td>Calculates gain coefficients based off data acquired during auto tuning. This command can be issued manually to calculate gains after manual modifications to the auto-tune acquired information.</td> </tr> </table>	0	"Idle"	Indicates the auto tune system can be used, written command forces the system to idle.	1	"Axis Tune"	Written as a command, initiates the auto tune process, messages will be displayed to enable axis, wait, disable axis. "Calculate" is also performed.	2	"Calculate"	Calculates gain coefficients based off data acquired during auto tuning. This command can be issued manually to calculate gains after manual modifications to the auto-tune acquired information.
0	"Idle"	Indicates the auto tune system can be used, written command forces the system to idle.								
1	"Axis Tune"	Written as a command, initiates the auto tune process, messages will be displayed to enable axis, wait, disable axis. "Calculate" is also performed.								
2	"Calculate"	Calculates gain coefficients based off data acquired during auto tuning. This command can be issued manually to calculate gains after manual modifications to the auto-tune acquired information.								
<p>[ATune Vel] This parameter specifies the maximum velocity of the motor attained during an auto tune cycle, as well as direction of movement.</p>	<p>Parameter Numbers 284, 285, 286, 287 Parameter Group ATune Config Display Units rpm Parameter Type Read/Write Change While Running Yes Linkable No Minimum Value -2000.0 rpm Maximum Value +2000.0 rpm Default Value +1000.0 rpm</p>									

<p>[Axis Type] Catalog number of Axis Module.</p> <p>Selection codes for 1394C-AM50-IH and 1394C-AM75-IH are the same as 1394x-AM50 and 1394x-AM75 respectively.</p>	<p>Parameter Numbers 328, 329, 330, 331 Parameter Group Configuration Parameter Type Read Only Linkable No Selections</p> <table border="0"> <tr><td>0</td><td>"NOT PRESENT"</td></tr> <tr><td>2</td><td>"1394x-AM03"</td></tr> <tr><td>3</td><td>"1394x-AM04"</td></tr> <tr><td>4</td><td>"1394x-AM07"</td></tr> <tr><td>5</td><td>"1394x-AM50"</td></tr> <tr><td>6</td><td>"1394x-AM75"</td></tr> <tr><td>8</td><td>"1394-DIM"</td></tr> </table>	0	"NOT PRESENT"	2	"1394x-AM03"	3	"1394x-AM04"	4	"1394x-AM07"	5	"1394x-AM50"	6	"1394x-AM75"	8	"1394-DIM"
0	"NOT PRESENT"														
2	"1394x-AM03"														
3	"1394x-AM04"														
4	"1394x-AM07"														
5	"1394x-AM50"														
6	"1394x-AM75"														
8	"1394-DIM"														
<p>[Bridge Lim] Axis module/motor combination absolute maximum current limit magnitude. Twice module current rating or three times motor current rating, whichever is less.</p>	<p>Parameter Numbers 260, 261, 262, 263 Parameter Group Linear List Display Units amps Parameter Type Read Only Linkable No</p>														
<p>[Bus Voltage] Displays the present value of the DC link (DC bus) voltage</p> <p>Active on all Smart Power 22 kW systems and 5 and 10 kW (Series C or later) systems only.</p> <p>Note: To determine the series of your module, refer to Figure P.1 in the <i>Preface</i>.</p>	<p>Parameter Numbers 39 Parameter Group Smart Sys Data Display Units vltS Parameter Type Read Only Linkable No</p>														
<p>[CCW OvSpd Vel] Counterclockwise trip velocity for an overspeed fault. This value is automatically set to 1000 rpm greater than [CCW Vel Lim] if this value would be greater than present setting.</p>	<p>Parameter Numbers 156, 157, 158, 159 Parameter Group Vel Cmd Data Display Units rpm Parameter Type Read/Write Change While Running Yes Linkable No Minimum Value 0.0 rpm Maximum Value 8000.0 rpm Default Value This is determined by the motor catalog number.</p>														
<p>[CCW Vel Lim] Velocity mode counterclockwise maximum command limit. This value is automatically set to the motor rated velocity when the motor parameter is changed.</p>	<p>Parameter Numbers 132, 133, 134, 135 Parameter Group Vel Cmd Data Display Units rpm Parameter Type Read/Write Change While Running Yes Linkable No Minimum Value 0.0 rpm Maximum Value 8000.0 rpm Default Value This is determined by the motor catalog number.</p>														

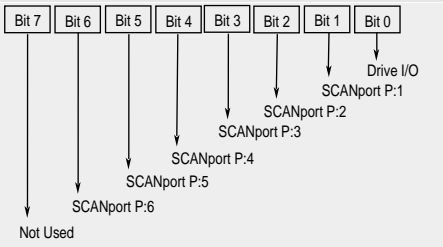
<p>[Command Mask] This parameter determines whether drive control from the indicated source is enabled or disabled. Stop commands from any source are not maskable. If the drive loses communications to a source (SCANport port) that has command control enabled, the drive will fault.</p>	<table border="0"> <tr> <td>Parameter Numbers</td> <td>21</td> </tr> <tr> <td>Parameter Group</td> <td>Setup</td> </tr> <tr> <td>Parameter Type</td> <td>Read/Write</td> </tr> <tr> <td>Change While Running</td> <td>Yes</td> </tr> <tr> <td>Linkable</td> <td>No</td> </tr> <tr> <td>Default</td> <td>01111111</td> </tr> </table> 	Parameter Numbers	21	Parameter Group	Setup	Parameter Type	Read/Write	Change While Running	Yes	Linkable	No	Default	01111111						
Parameter Numbers	21																		
Parameter Group	Setup																		
Parameter Type	Read/Write																		
Change While Running	Yes																		
Linkable	No																		
Default	01111111																		
<p>[Cur Fbk Rated] This parameter indicates the present full scale current rating of an axis module.</p>	<table border="0"> <tr> <td>Parameter Numbers</td> <td>268, 269, 270, 271</td> </tr> <tr> <td>Parameter Group</td> <td>Torq Data</td> </tr> <tr> <td>Display Units</td> <td>amps</td> </tr> <tr> <td>Parameter Type</td> <td>Read Only</td> </tr> <tr> <td>Linkable</td> <td>No</td> </tr> </table>	Parameter Numbers	268, 269, 270, 271	Parameter Group	Torq Data	Display Units	amps	Parameter Type	Read Only	Linkable	No								
Parameter Numbers	268, 269, 270, 271																		
Parameter Group	Torq Data																		
Display Units	amps																		
Parameter Type	Read Only																		
Linkable	No																		
<p>[Cur Fbk Scale] Setting of the axis module that selects the full scale feedback rating.</p>	<table border="0"> <tr> <td>Parameter Numbers</td> <td>264, 265, 266, 267</td> </tr> <tr> <td>Parameter Group</td> <td>Linear List</td> </tr> <tr> <td>Display Units</td> <td>None</td> </tr> <tr> <td>Parameter Type</td> <td>Read Only</td> </tr> <tr> <td>Linkable</td> <td>No</td> </tr> </table>	Parameter Numbers	264, 265, 266, 267	Parameter Group	Linear List	Display Units	None	Parameter Type	Read Only	Linkable	No								
Parameter Numbers	264, 265, 266, 267																		
Parameter Group	Linear List																		
Display Units	None																		
Parameter Type	Read Only																		
Linkable	No																		
<p>[Cur Lim Cause] This parameter displays the present source (if any) of current limiting for the axis.</p>	<table border="0"> <tr> <td>Parameter Numbers</td> <td>228, 229, 230, 231</td> </tr> <tr> <td>Parameter Group</td> <td>Torq Data</td> </tr> <tr> <td>Display Units</td> <td>None</td> </tr> <tr> <td>Parameter Type</td> <td>Read Only</td> </tr> <tr> <td>Linkable</td> <td>No</td> </tr> <tr> <td>Selections</td> <td> 0 "Not Limited" 1 "User Neg Lim" - current motor limit 2 "User Pos Lim" + current motor limit 3 "Bridge Lim" transistor current limit 4 "!(t) Limit" current vs. time limit before foldback 5 "Dyn Mtr Lim" motor speed/torque curve </td> </tr> </table>	Parameter Numbers	228, 229, 230, 231	Parameter Group	Torq Data	Display Units	None	Parameter Type	Read Only	Linkable	No	Selections	0 "Not Limited" 1 "User Neg Lim" - current motor limit 2 "User Pos Lim" + current motor limit 3 "Bridge Lim" transistor current limit 4 "!(t) Limit" current vs. time limit before foldback 5 "Dyn Mtr Lim" motor speed/torque curve						
Parameter Numbers	228, 229, 230, 231																		
Parameter Group	Torq Data																		
Display Units	None																		
Parameter Type	Read Only																		
Linkable	No																		
Selections	0 "Not Limited" 1 "User Neg Lim" - current motor limit 2 "User Pos Lim" + current motor limit 3 "Bridge Lim" transistor current limit 4 "!(t) Limit" current vs. time limit before foldback 5 "Dyn Mtr Lim" motor speed/torque curve																		
<p>[Cur Preload] This parameter specifies the amount of preload added to the velocity loop PI output, when [Torq Source] is configured to include a preload.</p>	<table border="0"> <tr> <td>Parameter Numbers</td> <td>164, 165, 166, 167</td> </tr> <tr> <td>Parameter Group</td> <td>Torq Data, AnBkIsh Conf</td> </tr> <tr> <td>Display Units</td> <td>amps</td> </tr> <tr> <td>Parameter Type</td> <td>Read/Write</td> </tr> <tr> <td>Change While Running</td> <td>Yes</td> </tr> <tr> <td>Linkable</td> <td>No</td> </tr> <tr> <td>Minimum Value</td> <td>-200% rated motor current</td> </tr> <tr> <td>Maximum Value</td> <td>+200% rated motor current</td> </tr> <tr> <td>Default Value</td> <td>0%</td> </tr> </table>	Parameter Numbers	164, 165, 166, 167	Parameter Group	Torq Data, AnBkIsh Conf	Display Units	amps	Parameter Type	Read/Write	Change While Running	Yes	Linkable	No	Minimum Value	-200% rated motor current	Maximum Value	+200% rated motor current	Default Value	0%
Parameter Numbers	164, 165, 166, 167																		
Parameter Group	Torq Data, AnBkIsh Conf																		
Display Units	amps																		
Parameter Type	Read/Write																		
Change While Running	Yes																		
Linkable	No																		
Minimum Value	-200% rated motor current																		
Maximum Value	+200% rated motor current																		
Default Value	0%																		

<p>[Cur Rate Lim]</p> <p>The largest change in the current reference per velocity loop sample that will be allowed is specified through this parameter. Value shown on the display is in amperes/millisecond. Description is based on percentage of motor rating to allow interpretation of value. This parameter is automatically configured to its maximum value when [Motor Type] (parameter 100) is changed.</p>	<table border="0"> <tr><td>Parameter Numbers</td><td>192, 193, 194, 195</td></tr> <tr><td>Parameter Group</td><td>Torq Data</td></tr> <tr><td>Display Units</td><td>A/ms</td></tr> <tr><td>Parameter Type</td><td>Read/Write</td></tr> <tr><td>Change While Running</td><td>Yes</td></tr> <tr><td>Linkable</td><td>No</td></tr> <tr><td>Minimum Value</td><td>10% rated motor current/ms</td></tr> <tr><td>Maximum Value</td><td>100% rated motor current/ms</td></tr> <tr><td>Default Value</td><td>100% rated motor current/ms</td></tr> </table>	Parameter Numbers	192, 193, 194, 195	Parameter Group	Torq Data	Display Units	A/ms	Parameter Type	Read/Write	Change While Running	Yes	Linkable	No	Minimum Value	10% rated motor current/ms	Maximum Value	100% rated motor current/ms	Default Value	100% rated motor current/ms
Parameter Numbers	192, 193, 194, 195																		
Parameter Group	Torq Data																		
Display Units	A/ms																		
Parameter Type	Read/Write																		
Change While Running	Yes																		
Linkable	No																		
Minimum Value	10% rated motor current/ms																		
Maximum Value	100% rated motor current/ms																		
Default Value	100% rated motor current/ms																		
<p>[Current Limit]</p> <p>This parameter automatically changes both positive and negative current limits to the same value (for convenience during commissioning).</p>	<table border="0"> <tr><td>Parameter Numbers</td><td>116, 117, 118, 119</td></tr> <tr><td>Parameter Group</td><td>Startup Parm</td></tr> <tr><td>Display Units</td><td>amps</td></tr> <tr><td>Parameter Type</td><td>Read/Write</td></tr> <tr><td>Change While Running</td><td>Yes</td></tr> <tr><td>Linkable</td><td>No</td></tr> <tr><td>Minimum Value</td><td>10% rated motor current</td></tr> <tr><td>Maximum Value</td><td>300% rated motor current</td></tr> <tr><td>Default Value</td><td>10% rated motor current</td></tr> </table>	Parameter Numbers	116, 117, 118, 119	Parameter Group	Startup Parm	Display Units	amps	Parameter Type	Read/Write	Change While Running	Yes	Linkable	No	Minimum Value	10% rated motor current	Maximum Value	300% rated motor current	Default Value	10% rated motor current
Parameter Numbers	116, 117, 118, 119																		
Parameter Group	Startup Parm																		
Display Units	amps																		
Parameter Type	Read/Write																		
Change While Running	Yes																		
Linkable	No																		
Minimum Value	10% rated motor current																		
Maximum Value	300% rated motor current																		
Default Value	10% rated motor current																		
<p>[CW OvSpd Vel]</p> <p>Clockwise trip velocity for an overspeed fault. This value is automatically set to 1000 rpm greater than [CCW Vel Lim] if this value would be greater than present setting.</p>	<table border="0"> <tr><td>Parameter Numbers</td><td>152, 153, 154, 155</td></tr> <tr><td>Parameter Group</td><td>Vel Cmd Data</td></tr> <tr><td>Display Units</td><td>rpm</td></tr> <tr><td>Parameter Type</td><td>Read/Write</td></tr> <tr><td>Change While Running</td><td>Yes</td></tr> <tr><td>Linkable</td><td>No</td></tr> <tr><td>Minimum Value</td><td>0 rpm</td></tr> <tr><td>Maximum Value</td><td>8000.0 rpm</td></tr> <tr><td>Default Value</td><td>This is determined by the motor catalog number.</td></tr> </table>	Parameter Numbers	152, 153, 154, 155	Parameter Group	Vel Cmd Data	Display Units	rpm	Parameter Type	Read/Write	Change While Running	Yes	Linkable	No	Minimum Value	0 rpm	Maximum Value	8000.0 rpm	Default Value	This is determined by the motor catalog number.
Parameter Numbers	152, 153, 154, 155																		
Parameter Group	Vel Cmd Data																		
Display Units	rpm																		
Parameter Type	Read/Write																		
Change While Running	Yes																		
Linkable	No																		
Minimum Value	0 rpm																		
Maximum Value	8000.0 rpm																		
Default Value	This is determined by the motor catalog number.																		
<p>[CW Vel Lim]</p> <p>Velocity mode clockwise maximum command limit. This value is automatically set to the motor rated velocity when the motor parameter is changed.</p>	<table border="0"> <tr><td>Parameter Numbers</td><td>128, 129, 130, 131</td></tr> <tr><td>Parameter Group</td><td>Vel Cmd Data</td></tr> <tr><td>Display Units</td><td>rpm</td></tr> <tr><td>Parameter Type</td><td>Read/Write</td></tr> <tr><td>Change While Running</td><td>Yes</td></tr> <tr><td>Linkable</td><td>No</td></tr> <tr><td>Minimum Value</td><td>0.0 rpm</td></tr> <tr><td>Maximum Value</td><td>8000.0 rpm</td></tr> <tr><td>Default Value</td><td>This is determined by the motor catalog number.</td></tr> </table>	Parameter Numbers	128, 129, 130, 131	Parameter Group	Vel Cmd Data	Display Units	rpm	Parameter Type	Read/Write	Change While Running	Yes	Linkable	No	Minimum Value	0.0 rpm	Maximum Value	8000.0 rpm	Default Value	This is determined by the motor catalog number.
Parameter Numbers	128, 129, 130, 131																		
Parameter Group	Vel Cmd Data																		
Display Units	rpm																		
Parameter Type	Read/Write																		
Change While Running	Yes																		
Linkable	No																		
Minimum Value	0.0 rpm																		
Maximum Value	8000.0 rpm																		
Default Value	This is determined by the motor catalog number.																		
<p>[D/A #x Gain]</p> <p>Scaling factor for the D/A output test point. For maximum resolution, this parameter should be set so $\text{Gain} = 128 / (\text{Maximum D/A Value})$. Where (Maximum D/A Value) is the largest value of the parameter that is linked to [D/A Value] (parameter 12). Important: Velocity is scaled for 4096 counts = 1000 rpm. Current (I_Q) is scaled for 8192 counts = 100% motor rated current.</p>	<table border="0"> <tr><td>Parameter Numbers</td><td>10, 11</td></tr> <tr><td>Parameter Group</td><td>Setup</td></tr> <tr><td>Display Units</td><td>None</td></tr> <tr><td>Parameter Type</td><td>Read/Write</td></tr> <tr><td>Change While Running</td><td>Yes</td></tr> <tr><td>Linkable</td><td>No</td></tr> <tr><td>Minimum Value</td><td>-2.0000</td></tr> <tr><td>Maximum Value</td><td>+2.0000</td></tr> <tr><td>Default Value</td><td>0.0000</td></tr> </table>	Parameter Numbers	10, 11	Parameter Group	Setup	Display Units	None	Parameter Type	Read/Write	Change While Running	Yes	Linkable	No	Minimum Value	-2.0000	Maximum Value	+2.0000	Default Value	0.0000
Parameter Numbers	10, 11																		
Parameter Group	Setup																		
Display Units	None																		
Parameter Type	Read/Write																		
Change While Running	Yes																		
Linkable	No																		
Minimum Value	-2.0000																		
Maximum Value	+2.0000																		
Default Value	0.0000																		

<p>[D/A #x Value] The unscaled value of the data that will be output on the D/A channel. This parameter must be the destination of link for any data to be output. All data output is treated as a signed word.</p>	<p>Parameter Numbers 12, 13 Parameter Group Linear List Display Units None Parameter Type Read/Write Linkable Yes Minimum Value -32768 Maximum Value +32767 Default Value 0</p>
<p>[DC Link Setup] This parameter selects the mode of operation for systems fault detection. Unless DC Link is shared, "standard" should be selected.</p>	<p>Parameter Numbers 50 Parameter Group Smart Sys Data Display Units None Parameter Type Read/Write Change While Running No Linkable No Default Value 0 "standard" Selections 0 "standard" 1 "shared w/3ph" 2 "shared - no 3ph"</p>
<p>[Desired BW] This is associated with the auto tune function and allows you to enter a desired velocity bandwidth less than or equal to the [Max Bandwidth] parameter as calculated by the auto tune cycle.</p>	<p>Parameter Numbers 252, 253, 254, 255 Parameter Group ATune Config Display Units Hz Parameter Type Read/Write Change While Running Yes Linkable No Minimum Value 1 Hz Maximum Value 60 Hz Default Value 30 Hz</p>
<p>[Dig Cmd Mode] This parameter determines whether digital velocity commands are treated as signed (Bipolar) inputs, or unsigned (Unipolar). If unipolar operation is selected, velocity direction is selected by the discrete direction commands.</p>	<p>Parameter Numbers 22 Parameter Group Setup Display Units None Parameter Type Read/Write Change While Running No Linkable No Default Value 0 "Bipolar" Selections 0 "Bipolar" 1 "Unipolar"</p>
<p>[Dig Torq Ref] This parameter is the present value of digital torque reference. This parameter must be the destination of link for any data to be output.</p>	<p>Parameter Numbers 212, 213, 214, 215 Parameter Group Torq Data Display Units amps Parameter Type Read/Write Linkable Yes</p>

<p>[Disp-D/A Monitor] This parameter quickly establishes links to the D/A test points. It will link the selected axis [Iq Cur Ref] to test point 1, and the [Vel Feedback] to test point 2. It will also link the [Vel Feedback] to all the SCANport analog display parameters.</p>	<p>Parameter Numbers 20 Parameter Group Setup Display Units None Parameter Type Read/Write Change While Running No Linkable No Default Value 0 "Axis 0" Selections 0 "Axis 0" 1 "Axis 1" 2 "Axis 2" 3 "Axis 3" 4 "Not Linked"</p>
<p>[Drive OK Mode] This parameter selects operation of the Drive OK relay. (DROK)</p>	<p>Parameter Numbers 19 Parameter Group Setup Display Units None Parameter Type Read/Write Change While Running Yes Linkable No Default Value 0 "Fault Only" Selections 0 "Fault Only" active fault opens DROK relay. 1 "Fault and UVlt" active fault or bus undervoltage opens DROK relay.</p>

<p>[Droop] This parameter is also referred to as "static gain." It effectively acts as a very slow discharge of the velocity loop integrator and has two uses:</p> <ul style="list-style-type: none"> • As a component of an external position loop system, setting this parameter to a higher, non-zero value will eliminate servo hunting due to load stick/slip friction effects. • As a deliberate "velocity droop" (secondary drives only) in multiple-motor systems where each drive axis is configured as a velocity loop and the motors are mechanically coupled together. Use of higher non-zero droop in this case promotes load sharing. This parameter selects the torque command source within the drive. When operating the drive in velocity mode, set to Velocity Mode 1 (#0). When operating in torque mode (using S Class), set to A/D Torque Block (#4). <p>This parameter selects the torque command source within the drive. When operating the drive in velocity mode, set to Velocity Mode 1 (#0). When operating in torque mode (using S Class), set to A/D Torque Block (#4).</p> <p>The droop scaling is defined as that specified droop in output rpm (i.e., velocity error) that will result in 100% rated torque being applied by the motor in reaction. This parameter only has effect if [Intg Gain Ki] is not zero.</p> <p>For Example: Speed regulation of 0 to 0.05% maximum depending on optimization of system performance settings. 3000 rpm, 0.05% = 1.5 rpm tolerance.</p>	<table border="0"> <tr> <td>Parameter Numbers</td> <td>380, 381, 382, 383</td> </tr> <tr> <td>Parameter Group</td> <td>Vel Loop Data</td> </tr> <tr> <td>Display Units</td> <td>rpm</td> </tr> <tr> <td>Parameter Type</td> <td>Read/Write</td> </tr> <tr> <td>Change While Running</td> <td>Yes</td> </tr> <tr> <td>Linkable</td> <td>No</td> </tr> <tr> <td>Minimum Value</td> <td>0.0 rpm (No Droop)</td> </tr> <tr> <td>Maximum Value</td> <td>15.6 rpm</td> </tr> <tr> <td>Default Value</td> <td>1.0 rpm</td> </tr> </table>	Parameter Numbers	380, 381, 382, 383	Parameter Group	Vel Loop Data	Display Units	rpm	Parameter Type	Read/Write	Change While Running	Yes	Linkable	No	Minimum Value	0.0 rpm (No Droop)	Maximum Value	15.6 rpm	Default Value	1.0 rpm
Parameter Numbers	380, 381, 382, 383																		
Parameter Group	Vel Loop Data																		
Display Units	rpm																		
Parameter Type	Read/Write																		
Change While Running	Yes																		
Linkable	No																		
Minimum Value	0.0 rpm (No Droop)																		
Maximum Value	15.6 rpm																		
Default Value	1.0 rpm																		
<p>[Enabled Days] Displays the number of days that the drive has been enabled.</p>	<table border="0"> <tr> <td>Parameter Numbers</td> <td>93</td> </tr> <tr> <td>Parameter Group</td> <td>Linear List</td> </tr> <tr> <td>Display Units</td> <td>None</td> </tr> <tr> <td>Parameter Type</td> <td>Read Only</td> </tr> <tr> <td>Linkable</td> <td>No</td> </tr> </table>	Parameter Numbers	93	Parameter Group	Linear List	Display Units	None	Parameter Type	Read Only	Linkable	No								
Parameter Numbers	93																		
Parameter Group	Linear List																		
Display Units	None																		
Parameter Type	Read Only																		
Linkable	No																		
<p>[Enabled Minutes] Displays the number of minutes that the drive has presently been enabled.</p>	<table border="0"> <tr> <td>Parameter Numbers</td> <td>92</td> </tr> <tr> <td>Parameter Group</td> <td>Linear List</td> </tr> <tr> <td>Display Units</td> <td>None</td> </tr> <tr> <td>Parameter Type</td> <td>Read Only</td> </tr> <tr> <td>Linkable</td> <td>No</td> </tr> </table>	Parameter Numbers	92	Parameter Group	Linear List	Display Units	None	Parameter Type	Read Only	Linkable	No								
Parameter Numbers	92																		
Parameter Group	Linear List																		
Display Units	None																		
Parameter Type	Read Only																		
Linkable	No																		
<p>[Fdbk Pole Cnt] The number of electrical poles on the resolver.</p> <p>Note: Before making modifications to Mtr Data parameters, [Motor Type] must be set to "custom motor".</p>	<table border="0"> <tr> <td>Parameter Numbers</td> <td>400</td> </tr> <tr> <td>Parameter Group</td> <td>Mtr Data</td> </tr> <tr> <td>Display Units</td> <td>None</td> </tr> <tr> <td>Parameter Type</td> <td>Read/Write</td> </tr> <tr> <td>Change While Running</td> <td>No</td> </tr> <tr> <td>Linkable</td> <td>No</td> </tr> <tr> <td>Minimum Value</td> <td>2</td> </tr> <tr> <td>Maximum Value</td> <td>8</td> </tr> <tr> <td>Default Value</td> <td>This is determined by the motor catalog number.</td> </tr> </table>	Parameter Numbers	400	Parameter Group	Mtr Data	Display Units	None	Parameter Type	Read/Write	Change While Running	No	Linkable	No	Minimum Value	2	Maximum Value	8	Default Value	This is determined by the motor catalog number.
Parameter Numbers	400																		
Parameter Group	Mtr Data																		
Display Units	None																		
Parameter Type	Read/Write																		
Change While Running	No																		
Linkable	No																		
Minimum Value	2																		
Maximum Value	8																		
Default Value	This is determined by the motor catalog number.																		

<p>[Feed Fwd Gain] Controls the negative feedforward gain of the velocity command contribution to the velocity regulator torque loop. Setting this to a value greater than zero reduces the velocity feedback overshoot in response to a step change in the velocity reference. The velocity loop response to a load disturbance is unaffected by the Feed Forward Gain. The default value will be satisfactory in most cases.</p>	<p>Parameter Numbers 376, 377, 378, 379 Parameter Group Vel Loop Data Display Units None Parameter Type Read/Write Change While Running Yes Linkable No Minimum Value 0% of [Vel Command] Maximum Value 100% of [Vel Command] Default Value 0</p>
<p>[Hardware Version] This parameter specifies the revision level of the system module hardware.</p>	<p>Parameter Numbers 25 Parameter Group Monitor Parm Display Units None Parameter Type Read Only Linkable No</p>
<p>[I(t) Cur Lim] This parameter displays the present level of the I(t) current limit for this axis.</p>	<p>Parameter Numbers 344, 345, 346, 347 Parameter Group Linear List Display Units amps Parameter Type Read Only Linkable No</p>
<p>[Id Cur Ref] This parameter displays the present level of the Id current reference for this axis.</p>	<p>Parameter Numbers 236, 237, 238, 239 Parameter Group Torq Data Display Units amps Parameter Type Read Only Linkable No</p>
<p>[Id RPM End] This parameter determines the velocity at which maximum Id current will be applied. It is automatically changed when a motor is selected by [Motor Type].</p> <p>Note: Before making modifications to Mtr Data parameters, [Motor Type] must be set to "custom motor".</p>	<p>Parameter Numbers 176, 177, 178, 179 Parameter Group Mtr Data Display Units rpm Parameter Type Read/Write Change While Running Yes Linkable No Minimum Value 0.0 rpm Maximum Value 8000.0 rpm Default Value This is determined by the motor catalog number.</p>
<p>[Id RPM Start] This parameter determines the velocity at which Id current will start to be applied. It is automatically changed when a motor is selected by [Motor Type].</p> <p>Note: Before making modifications to Mtr Data parameters, [Motor Type] must be set to "custom motor".</p>	<p>Parameter Numbers 172, 173, 174, 175 Parameter Group Mtr Data Display Units rpm Parameter Type Read/Write Change While Running Yes Linkable No Minimum Value 0.0 rpm Maximum Value 5600.0 rpm Default Value This is determined by the motor catalog number.</p>

<p>[Id Slope] Determines the amount of Id current (as a percent of motor rated) that would be required over a 1000 rpm span. It is automatically changed when a motor is selected by [Motor Type].</p> <p>Note: Before making modifications to Mtr Data parameters, [Motor Type] must be set to "custom motor".</p>	<p>Parameter Numbers 180, 181, 182, 183 Parameter Group Mtr Data Display Units %/Kr Parameter Type Read/Write Change While Running Yes Linkable No Minimum Value 0.0%/Kr Maximum Value 400.0%/Kr Default Value 70.0%/Kr</p>
<p>[Int Torq Ref] This is a non-volatile torque preset that can be used as a digital torque reference if linked to [Dig Torq ref]. Important: Current limits will prevent [Iq Cur Ref] from exceeding 300%.</p>	<p>Parameter Numbers 356, 357, 358, 359 Parameter Group Torq Data Display Units amps Parameter Type Read/Write Change While Running Yes Linkable No Minimum Value -400% rated motor current Maximum Value +400% rated motor current Default Value 0%</p>
<p>[Int Vel Ref] This is a non-volatile velocity preset that can be used as a digital velocity reference if linked to [Vel Ref Whole]. The "sign" of this parameter is changed by direction change requests.</p>	<p>Parameter Numbers 352, 353, 354, 355 Parameter Group Vel Cmd Data Display Units rpm Parameter Type Read/Write Change While Running Yes Linkable No Minimum Value -8000.0 rpm Maximum Value +8000.0 rpm Default Value 0.0 rpm</p>
<p>[Intg Gain Ki] This parameter controls the integral error gain of the velocity regulator. For example, if KI = 8, then velocity (1000 rpm) error for 1 second will produce a (rated motor) current torque reference. For Example: Use Ki to increase servo stiffness or reduce the amount of overshoot during ramp-up to the [Velocity Command].</p>	<p>Parameter Numbers 372, 373, 374, 375 Parameter Group ATune Config, AnBklsh Conf Display Units None Parameter Type Read/Write Change While Running Yes Linkable No Minimum Value 0 Maximum Value 32879 Default Value 0</p>
<p>[Iq Cur Ref] This parameter displays the present level of the Iq current reference for this axis (after all limiting has occurred)</p>	<p>Parameter Numbers 232, 233, 234, 235 Parameter Group Monitor Parm's, Torq data Display Units amps Parameter Type Read Only Linkable No</p>
<p>[Jog Vel] This is a jog velocity reference that is used when jogging the axis. The "sign" of this parameter is changed by direction change requests and is automatically changed to 20% of motor rated velocity when a motor is selected by [Motor Type].</p>	<p>Parameter Numbers 348, 349, 350, 351 Parameter Group Vel Cmd Data Display Units rpm Parameter Type Read/Write Change While Running Yes Linkable No Minimum Value -1600.0 rpm Maximum Value +1600.0 rpm Default Value This is determined by the motor catalog number.</p>

[Language Sel]	Display language for text.	Parameter Numbers 4 Parameter Group Linear List Display Units None Parameter Type Read/Write Change While Running Yes Linkable No Default Value 0 English Selections 0 English
[Ld/Lg Degrees]	<p>If [Ld/Lg Freq] and [Ld/Lg Degrees] are set to non-zero values, a lead/lag filter (one pole, one zero) is additionally inserted into the feedback path of the velocity loop. This filter can be used to enhance the stability of the loop in the presence of load resonances.</p> <p>This parameter specifies the amount of phase shift that occurs at the lead/lag center frequency. A negative value specifies a lag, while a positive value specifies a lead.</p> <p>In most cases, this filter will not be needed.</p>	Parameter Numbers 144, 145, 146, 147 Parameter Group Vel Loop Tune Display Units degs Parameter Type Read/Write Change While Running Yes Linkable No Minimum Value -50 (lag) degs Maximum Value +50 (lead) degs Default Value 0 degs
[Ld/Lg Freq]	<p>This parameter specifies the center frequency of the lead/lag filter in the velocity feedback path if employed (see [Ld/Lg Degrees]). If set to zero, the filter is disabled.</p> <p>In most cases, this filter will not be needed.</p>	Parameter Numbers 148, 149, 150, 151 Parameter Group Vel Loop Tune Display Units Hz Parameter Type Read/Write Change While Running Yes Linkable No Minimum Value 0 Hz Maximum Value 200 Hz Default Value 0 Hz
[Line Voltage]	<p>This parameter selects input line voltage being used. It affects motor velocity ratings and must be configured prior to selecting motor types.</p> <p>This value is set automatically in all Smart Power 22 kW systems and 5 and 10 kW (Series C or later) systems.</p>	Parameter Numbers 9 Parameter Group Configuration, Setup Display Units None Parameter Type Read/Write Change While Running Yes Linkable No Default Value 0 460 Volts AC Selections 0 460 Volts AC 1 380 Volts AC
[Max Bandwidth]	<p>After an auto tune, this parameter displays the maximum system bandwidth that can be achieved with the machine mechanics.</p>	Parameter Numbers 304, 305, 306, 307 Parameter Group ATune Config Display Units Hz Parameter Type Read Only Linkable No

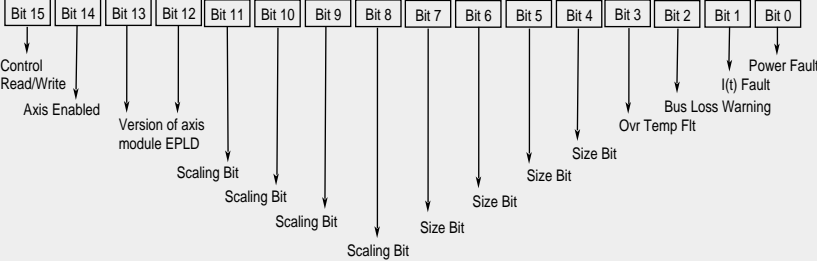
<p>[Mod Rng Data] Diagnostic information of data communicated between the controller and Axis Module.</p>	<p>Parameter Numbers 196, 197, 198, 199 Parameter Group Linear List Parameter Type Read Only</p> 
<p>[Mode Sel] This parameter modifies both [Vel Source] and [Torq Source] to appropriate value based on selection (for convenience during commissioning).</p>	<p>Parameter Numbers 112, 113, 114, 115 Parameter Group Configuration, Startup Parm Display Units None Parameter Type Read/Write Change While Running Yes Linkable No Default Value 0 "Anlg Vel" Selections 0 "Anlg Vel" 1 "Ana Torq" 2 "Dig Vel" 3 "Dig Torq"</p>
<p>[Module Size] Current rating of the Axis Module. This is set after the initialization of the 1394 Analog Servo System DSP.</p>	<p>Parameter Numbers 324, 325, 326, 327 Parameter Group Torq Data Display Units amps Parameter Type Read Only Linkable No</p>

<p>[Motor Type] The catalog number of the motor is attached to the axis. Important: This parameter configures many other parameters, set it carefully.</p> <p>Note: Before making modifications to Mtr Data parameters, [Motor Type] must be set to "custom motor".</p> <p>Note: Motors numbered 11 through 15 are available with Firmware version 2.01 or later.</p> <p>Note: Selection number might vary for parameters 404-407.</p>	<table> <tr> <td>Parameter Numbers</td> <td>100, 101, 102, 103, 404, 405, 406, 407</td> </tr> <tr> <td>Parameter Group</td> <td>Configuration, Startup Parm, Mtr Data</td> </tr> <tr> <td>Display Units</td> <td>None</td> </tr> <tr> <td>Parameter Type</td> <td>Read/Write</td> </tr> <tr> <td>Change While Running</td> <td>No</td> </tr> <tr> <td>Linkable</td> <td>No</td> </tr> <tr> <td>Default Value</td> <td>0 "custom motor"</td> </tr> <tr> <td>Selections</td> <td>0 "custom motor"</td> </tr> <tr> <td></td> <td>1 "1326AB-B410G"</td> </tr> <tr> <td></td> <td>2 "1326AB-B420E"</td> </tr> <tr> <td></td> <td>3 "1326AB-B430E"</td> </tr> <tr> <td></td> <td>4 "1326AB-B515E"</td> </tr> <tr> <td></td> <td>5 "1326AB-B520E"</td> </tr> <tr> <td></td> <td>6 "1326AB-B530E"</td> </tr> <tr> <td></td> <td>7 "1326AB-B410J"</td> </tr> <tr> <td></td> <td>8 "1326AB-B420H"</td> </tr> <tr> <td></td> <td>9 "1326AB-B430G"</td> </tr> <tr> <td></td> <td>10 "1326AB-B515G"</td> </tr> <tr> <td></td> <td>11 "1326AB-B520F"</td> </tr> <tr> <td></td> <td>12 "1326AS-B310H"</td> </tr> <tr> <td></td> <td>13 "1326AS-B330H"</td> </tr> <tr> <td></td> <td>14 "1326AS-B420G"</td> </tr> <tr> <td></td> <td>15 "1326AS-B440G"</td> </tr> <tr> <td></td> <td>16 "1326AS-B460F"</td> </tr> <tr> <td></td> <td>17 "1326AB-B720E"</td> </tr> <tr> <td></td> <td>18 "1326AB-B730E"</td> </tr> <tr> <td></td> <td>19 "1326AB-B740C"</td> </tr> <tr> <td></td> <td>20 "1326AS-B210H"</td> </tr> <tr> <td></td> <td>21 "1326AS-B220H"</td> </tr> <tr> <td></td> <td>22 "1326AS-B630F"</td> </tr> <tr> <td></td> <td>23 "1326AS-B660E"</td> </tr> <tr> <td></td> <td>24 "1326AS-B690E"</td> </tr> <tr> <td></td> <td>25 "1326AS-B840E"</td> </tr> <tr> <td></td> <td>26 "1326AS-B860C"</td> </tr> <tr> <td></td> <td>27 "1326AB-B505C"</td> </tr> <tr> <td></td> <td>28 "1326AS-B360F"</td> </tr> <tr> <td></td> <td>29 "1326AS-B515C"</td> </tr> <tr> <td></td> <td>30 "1326AS-B360Z"</td> </tr> <tr> <td></td> <td>31 "1326AB-B720C"</td> </tr> <tr> <td></td> <td>32 "1326AB-B720F"</td> </tr> <tr> <td></td> <td>33 "1326AB-B420C"</td> </tr> <tr> <td></td> <td>34 "1326AB-B530C"</td> </tr> <tr> <td></td> <td>35 "1326AN-B320H"</td> </tr> <tr> <td></td> <td>36 "External"</td> </tr> <tr> <td></td> <td>37 "1326AB-B740E"</td> </tr> </table>	Parameter Numbers	100, 101, 102, 103, 404, 405, 406, 407	Parameter Group	Configuration, Startup Parm, Mtr Data	Display Units	None	Parameter Type	Read/Write	Change While Running	No	Linkable	No	Default Value	0 "custom motor"	Selections	0 "custom motor"		1 "1326AB-B410G"		2 "1326AB-B420E"		3 "1326AB-B430E"		4 "1326AB-B515E"		5 "1326AB-B520E"		6 "1326AB-B530E"		7 "1326AB-B410J"		8 "1326AB-B420H"		9 "1326AB-B430G"		10 "1326AB-B515G"		11 "1326AB-B520F"		12 "1326AS-B310H"		13 "1326AS-B330H"		14 "1326AS-B420G"		15 "1326AS-B440G"		16 "1326AS-B460F"		17 "1326AB-B720E"		18 "1326AB-B730E"		19 "1326AB-B740C"		20 "1326AS-B210H"		21 "1326AS-B220H"		22 "1326AS-B630F"		23 "1326AS-B660E"		24 "1326AS-B690E"		25 "1326AS-B840E"		26 "1326AS-B860C"		27 "1326AB-B505C"		28 "1326AS-B360F"		29 "1326AS-B515C"		30 "1326AS-B360Z"		31 "1326AB-B720C"		32 "1326AB-B720F"		33 "1326AB-B420C"		34 "1326AB-B530C"		35 "1326AN-B320H"		36 "External"		37 "1326AB-B740E"
Parameter Numbers	100, 101, 102, 103, 404, 405, 406, 407																																																																																										
Parameter Group	Configuration, Startup Parm, Mtr Data																																																																																										
Display Units	None																																																																																										
Parameter Type	Read/Write																																																																																										
Change While Running	No																																																																																										
Linkable	No																																																																																										
Default Value	0 "custom motor"																																																																																										
Selections	0 "custom motor"																																																																																										
	1 "1326AB-B410G"																																																																																										
	2 "1326AB-B420E"																																																																																										
	3 "1326AB-B430E"																																																																																										
	4 "1326AB-B515E"																																																																																										
	5 "1326AB-B520E"																																																																																										
	6 "1326AB-B530E"																																																																																										
	7 "1326AB-B410J"																																																																																										
	8 "1326AB-B420H"																																																																																										
	9 "1326AB-B430G"																																																																																										
	10 "1326AB-B515G"																																																																																										
	11 "1326AB-B520F"																																																																																										
	12 "1326AS-B310H"																																																																																										
	13 "1326AS-B330H"																																																																																										
	14 "1326AS-B420G"																																																																																										
	15 "1326AS-B440G"																																																																																										
	16 "1326AS-B460F"																																																																																										
	17 "1326AB-B720E"																																																																																										
	18 "1326AB-B730E"																																																																																										
	19 "1326AB-B740C"																																																																																										
	20 "1326AS-B210H"																																																																																										
	21 "1326AS-B220H"																																																																																										
	22 "1326AS-B630F"																																																																																										
	23 "1326AS-B660E"																																																																																										
	24 "1326AS-B690E"																																																																																										
	25 "1326AS-B840E"																																																																																										
	26 "1326AS-B860C"																																																																																										
	27 "1326AB-B505C"																																																																																										
	28 "1326AS-B360F"																																																																																										
	29 "1326AS-B515C"																																																																																										
	30 "1326AS-B360Z"																																																																																										
	31 "1326AB-B720C"																																																																																										
	32 "1326AB-B720F"																																																																																										
	33 "1326AB-B420C"																																																																																										
	34 "1326AB-B530C"																																																																																										
	35 "1326AN-B320H"																																																																																										
	36 "External"																																																																																										
	37 "1326AB-B740E"																																																																																										
<p>[Mt Power Usage] Displays the present average power delivered to all motors from the system module.</p> <p>Active on all Smart Power 22 kW systems and 5 and 10 kW (Series C or later) systems.</p>	<table> <tr> <td>Parameter Numbers</td> <td>41</td> </tr> <tr> <td>Parameter Group</td> <td>Smart Sys Data</td> </tr> <tr> <td>Display Units</td> <td>%</td> </tr> <tr> <td>Parameter Type</td> <td>Read Only</td> </tr> <tr> <td>Linkable</td> <td>No</td> </tr> </table>	Parameter Numbers	41	Parameter Group	Smart Sys Data	Display Units	%	Parameter Type	Read Only	Linkable	No																																																																																
Parameter Numbers	41																																																																																										
Parameter Group	Smart Sys Data																																																																																										
Display Units	%																																																																																										
Parameter Type	Read Only																																																																																										
Linkable	No																																																																																										

<p>[Mtr Inertia] Inertia of motor attached to drive. Automatically changed when [Motor Type] is changed (to motor is inertia + 20% for coupling) (Inertia is defined as time in milliseconds required to reach 1000 rpm at rated motor current). It is used as input to the auto tune procedure.</p> <p>Note: Before making modifications to Mtr Data parameters, [Motor Type] must be set to "custom motor".</p>	<p>Parameter Numbers 108, 109, 110, 111 Parameter Group Mtr Data Display Units msec Parameter Type Read/Write Change While Running Yes Linkable No Minimum Value 0 msec Maximum Value 500 msec Default Value 100 msec</p>
<p>[Mtr Peak Cur] Motor peak current.</p> <p>Note: Before making modifications to Mtr Data parameters, [Motor Type] must be set to "custom motor".</p>	<p>Parameter Numbers 124, 125, 126, 127 Parameter Group Mtr Data Display Units amps Parameter Type Read/Write Change While Running No Linkable No Minimum Value 0 % Maximum Value 300 % Default Value Rated motor peak current</p>
<p>[Mtr Pole Cnt] The number of electrical poles on the motor.</p> <p>Note: Before making modifications to Mtr Data parameters, [Motor Type] must be set to "custom motor".</p>	<p>Parameter Numbers 396 Parameter Group Mtr Data Display Units None Parameter Type Read/Write Change While Running No Linkable No Minimum Value 2 Maximum Value 8 Default Value This is determined by the motor catalog number.</p>
<p>[Mtr Rated Cur] Motor nameplate rated current. Automatically changed when [Motor Type] is changed. This value will be clamped to the current rating of the axis module if the motor rating is larger than the module.</p> <p>Note: Before making modifications to Mtr Data parameters, [Motor Type] must be set to "custom motor".</p>	<p>Parameter Numbers 104, 105, 106, 107 Parameter Group Mtr Data Display Units amps Parameter Type Read/Write Change While Running No Linkable No Minimum Value 0% Maximum Value 100% Default Value 0%</p>
<p>[Neg Cur Lim] The maximum allowable negative motor current that can be commanded is specified through this parameter. If greater than [Bridge Lim], then [Bridge Lim] will set the limits. Important: Setting this parameter to a value other than default will limit motor output torque in CCW direction. For Example: If the value equals 100%, the axis module will not deliver more than 100% to motor, thus peak torque is limited to 100%.</p>	<p>Parameter Numbers 188, 189, 190, 191 Parameter Group Torq Data Display Units amps Parameter Type Read/Write Change While Running Yes Linkable No Minimum Value 10% rated motor current Maximum Value 300% rated motor current or 2 times drive rating (whichever is less) Default Value 300% rated motor current</p>

<p>[Option x Code] Used for software options Option 0 = Antibacklash Option 1 = Future Option 2 = Future Option 3 = Future</p>	<p>Parameter Numbers 30, 32, 34, 36 Parameter Group Linear List Display Units None Parameter Type Read/Write Change While Running Yes Linkable No Minimum Value 0 Maximum Value 65535 Default Value 0</p>
<p>[Option x Status] Present status of a software option (enabled/disabled). Once enabled via the [Option x Code] the status will be stored in non-volatile memory for future use.</p>	<p>Parameter Numbers 31, 33, 35, 37 Parameter Group Linear List Display Units None Parameter Type Read Only Linkable No Selections 0 "Disabled" 1 "Enabled"</p>
<p>[Pos Cur Lim] Specifies the maximum allowable positive motor current that can be commanded. Important: Setting this parameter to a value other than default will limit motor output torque in CW direction. Automatically changed when [Current Limit] (parameter 116) is changed. For Example: If the value equals 100%, the Axis Module will not deliver more than 100% to motor, thus peak torque is limited to 100%.</p>	<p>Parameter Numbers 184, 185, 186, 187 Parameter Group Torq Data Display Units amps Parameter Type Read/Write Change While Running Yes Linkable No Minimum Value 10% rated motor current Maximum Value 300% rated motor current or 2 times drive rating (whichever is less) Default Value 300% rated motor current</p>
<p>[Prop Gain Kp] This parameter controls the proportional error gain of the velocity regulator. For example, if $KP = 1$, then velocity error of 1000 rpm will produce a (rated motor) current torque reference. Increase this value to attain a stiffer, more precise response.</p>	<p>Parameter Numbers 368, 369, 370, 371 Parameter Group Vel Loop Tune, AnBklsh Conf Display Units None Parameter Type Read/Write Change While Running Yes Linkable No Minimum Value 0 Maximum Value 1024 Default Value 0</p>
<p>[Pwr On Days] Displays the number of days that the drive has had control power applied.</p>	<p>Parameter Numbers 91 Parameter Group Linear List Display Units None Parameter Type Read Only Linkable No</p>
<p>[Pwr On Minutes] Displays the number of minutes that the drive has presently had control power applied.</p>	<p>Parameter Numbers 90 Parameter Group Linear List Display Units None Parameter Type Read Only Linkable No</p>
<p>[Rem. Data In/Out:Ax] This series of parameters represent linkable inputs and outputs to the SCANport Type 4/5/6/7 DataLink inputs and outputs.</p>	<p>Parameter Numbers 70-85 Parameter Group Linear List Display Units None Parameter Type Read Only Linkable In=No, Out=Yes</p>

<p>[Rem. Data In/Out:Px] This series of parameters represent linkable inputs and outputs to the SCANport "analog" inputs and outputs for each of the six available ports.</p>	<p>Parameter Numbers 58-69 Parameter Group Linear List Display Units None Parameter Type Read Only Linkable In=No, Out=Yes</p>
<p>[Resolvr Posn] This parameter supplies the position feedback count. 65,535 represents the counts per 1/2 revolution.</p>	<p>Parameter Numbers 216, 217, 218, 219 Parameter Group Monitor Parm Display Units None Parameter Type Read Only Linkable No</p>
<p>[Resolvr Turns] The number of resolver electrical turns is supplied by this parameter. When these values reach maximum, the value drops to -32768 and begins to again count up and down.</p>	<p>Parameter Numbers 244, 245, 246, 247 Parameter Group Monitor Parm Display Units None Parameter Type Read Only Linkable No</p>
<p>[Rg Power Usage] Displays the present average power regenerated by all motors back to the system module.</p> <p>Active on all Smart Power 22 kW systems and 5 and 10 kW (Series C or later) systems.</p>	<p>Parameter Numbers 40 Parameter Group Smart Sys Data Display Units % Parameter Type Read Only Linkable No</p>
<p>[Shunt KI] Shunt resistor long time constant, measured in seconds.</p> <p>Active on all Smart Power 22 kW systems and 5 and 10 kW (Series C or later) systems.</p> <p>This parameter only needs to be configured when you are using custom resistors.</p> <p>Note: [Shunt Type] must be set to "custom shunt" before making modifications to this shunt parameter (44-48).</p>	<p>Parameter Numbers 47 Parameter Group Linear List Display Units S Parameter Type Read/Write Change While Running No Minimum Value 1 Maximum Value 255 Default Value (22 kW) 70 Default Value (5 and 10 kW) 10</p>
<p>[Shunt Ks] Shunt resistor short time constant, measured in seconds.</p> <p>Active on all Smart Power 22 kW systems and 5 and 10 kW (Series C or later) systems.</p> <p>This parameter only needs to be configured when you are using custom resistors.</p> <p>Note: [Shunt Type] must be set to "custom shunt" before making modifications to this shunt parameter (44-48).</p>	<p>Parameter Numbers 46 Parameter Group Linear List Display Units ms Parameter Type Read/Write Change While Running No Minimum Value 250 Maximum Value 2550 Default Value (22 kW) 250 Default Value (5 and 10 kW) 250</p>

<p>[Shunt P] Shunt resistor continuous power rating.</p> <p>Active on all Smart Power 22 kW systems and 5 and 10 kW (Series C or later) systems.</p> <p>This parameter only needs to be configured when you are using custom resistors.</p> <p>Note: [Shunt Type] must be set to "custom shunt" before making modifications to this shunt parameter (44-48).</p>	<table border="0"> <tr><td>Parameter Numbers</td><td>45</td></tr> <tr><td>Parameter Group</td><td>Linear List</td></tr> <tr><td>Display Units</td><td>Watts</td></tr> <tr><td>Parameter Type</td><td>Read/Write</td></tr> <tr><td>Change While Running</td><td>No</td></tr> <tr><td>Minimum Value</td><td>100</td></tr> <tr><td>Maximum Value</td><td>22000</td></tr> <tr><td>Default Value (22 kW)</td><td>900</td></tr> <tr><td>Default Value (5 and 10 kW)</td><td>200</td></tr> </table>	Parameter Numbers	45	Parameter Group	Linear List	Display Units	Watts	Parameter Type	Read/Write	Change While Running	No	Minimum Value	100	Maximum Value	22000	Default Value (22 kW)	900	Default Value (5 and 10 kW)	200
Parameter Numbers	45																		
Parameter Group	Linear List																		
Display Units	Watts																		
Parameter Type	Read/Write																		
Change While Running	No																		
Minimum Value	100																		
Maximum Value	22000																		
Default Value (22 kW)	900																		
Default Value (5 and 10 kW)	200																		
<p>[Shunt Peak Usage] This parameter shows the peak usage of the shunt resistor over the last ten seconds. (%) This parameter can be observed to determine proximity of usage to fault condition. Warning is set at 80%. Fault is set when value reaches 105%.</p> <p>Active on all Smart Power 22 kW systems and 5 and 10 kW (Series C or later) systems.</p>	<table border="0"> <tr><td>Parameter Numbers</td><td>51</td></tr> <tr><td>Parameter Group</td><td>Smart Sys Data</td></tr> <tr><td>Display Units</td><td>%</td></tr> <tr><td>Parameter Type</td><td>Read Only</td></tr> <tr><td>Linkable</td><td>No</td></tr> </table>	Parameter Numbers	51	Parameter Group	Smart Sys Data	Display Units	%	Parameter Type	Read Only	Linkable	No								
Parameter Numbers	51																		
Parameter Group	Smart Sys Data																		
Display Units	%																		
Parameter Type	Read Only																		
Linkable	No																		
<p>[Shunt R] Shunt resistor resistance. Set this parameter only when using a custom resistor.</p> <p>Active on all Smart Power 22 kW systems and 5 and 10 kW (Series C or later) systems.</p> <p>Note: [Shunt Type] must be set to "custom shunt" before making modifications to this shunt parameter (44-48).</p>	<table border="0"> <tr><td>Parameter Numbers</td><td>44</td></tr> <tr><td>Parameter Group</td><td>Linear List</td></tr> <tr><td>Display Units</td><td>Ohms</td></tr> <tr><td>Parameter Type</td><td>Read/Write</td></tr> <tr><td>Change While Running</td><td>No</td></tr> <tr><td>Minimum Value</td><td>4 (22kW systems) 16 (5 and 10 kW systems)</td></tr> <tr><td>Maximum Value</td><td>255</td></tr> <tr><td>Default Value</td><td>Set by [Shunt Type]</td></tr> </table>	Parameter Numbers	44	Parameter Group	Linear List	Display Units	Ohms	Parameter Type	Read/Write	Change While Running	No	Minimum Value	4 (22kW systems) 16 (5 and 10 kW systems)	Maximum Value	255	Default Value	Set by [Shunt Type]		
Parameter Numbers	44																		
Parameter Group	Linear List																		
Display Units	Ohms																		
Parameter Type	Read/Write																		
Change While Running	No																		
Minimum Value	4 (22kW systems) 16 (5 and 10 kW systems)																		
Maximum Value	255																		
Default Value	Set by [Shunt Type]																		
<p>[Shunt Type] Selects shunt module model number or type.</p> <p>Active on all Smart Power 22 kW systems and 5 and 10 kW (Series C or later) systems.</p> <p>Note: [Shunt Type] must be set to "custom shunt" before making modifications to associated shunt parameters (44-48).</p>	<table border="0"> <tr><td>Parameter Numbers</td><td>43, 49</td></tr> <tr><td>Parameter Group</td><td>Linear List</td></tr> <tr><td>Display Units</td><td>None</td></tr> <tr><td>Parameter Type</td><td>Read/Write</td></tr> <tr><td>Change While Running</td><td>No</td></tr> <tr><td>Linkable</td><td>No</td></tr> <tr><td>Default Value</td><td>1 "1394-SR-9A" (22 kW systems) 6 "Internal" (5 and 10 kW systems)</td></tr> <tr><td>Selections</td><td>0 "Custom Shunt" 1 "1394-SR-9A" 2 "1394-SR-9AF" 3 "1394-SR-36A" 4 "1394-SR-36AF" 5 "1394-SR-10A" 6 "Internal" (5 and 10 kW systems)</td></tr> </table>	Parameter Numbers	43, 49	Parameter Group	Linear List	Display Units	None	Parameter Type	Read/Write	Change While Running	No	Linkable	No	Default Value	1 "1394-SR-9A" (22 kW systems) 6 "Internal" (5 and 10 kW systems)	Selections	0 "Custom Shunt" 1 "1394-SR-9A" 2 "1394-SR-9AF" 3 "1394-SR-36A" 4 "1394-SR-36AF" 5 "1394-SR-10A" 6 "Internal" (5 and 10 kW systems)		
Parameter Numbers	43, 49																		
Parameter Group	Linear List																		
Display Units	None																		
Parameter Type	Read/Write																		
Change While Running	No																		
Linkable	No																		
Default Value	1 "1394-SR-9A" (22 kW systems) 6 "Internal" (5 and 10 kW systems)																		
Selections	0 "Custom Shunt" 1 "1394-SR-9A" 2 "1394-SR-9AF" 3 "1394-SR-36A" 4 "1394-SR-36AF" 5 "1394-SR-10A" 6 "Internal" (5 and 10 kW systems)																		
<p>[Shunt Usage] % of shunt power used.</p> <p>Active on all Smart Power 22 kW systems and 5 and 10 kW (Series C or later) systems.</p>	<table border="0"> <tr><td>Parameter Numbers</td><td>42</td></tr> <tr><td>Parameter Group</td><td>Smart Sys Data</td></tr> <tr><td>Display Units</td><td>%</td></tr> <tr><td>Parameter Type</td><td>Read Only</td></tr> <tr><td>Linkable</td><td>No</td></tr> </table>	Parameter Numbers	42	Parameter Group	Smart Sys Data	Display Units	%	Parameter Type	Read Only	Linkable	No								
Parameter Numbers	42																		
Parameter Group	Smart Sys Data																		
Display Units	%																		
Parameter Type	Read Only																		
Linkable	No																		

<p>[Shunt Ws] Shunt short time constant weighting factor. This parameter determines the relationship between the short and long time constants in the thermal model of the shunt module. The long time constant weighting factor is 100% - Ws%. Configure this parameter only when a custom resistor is selected.</p> <p>Active on all Smart Power 22 kW systems and 5 and 10 kW (Series C or later) systems.</p> <p>Note: [Shunt Type] must be set to "custom shunt" before making modifications to associated shunt parameters (44-48).</p>	<p>Parameter Numbers 48 Parameter Group Linear List Display Units % Parameter Type Read/Write Change While Running No Minimum Value 1 Maximum Value 100 Default Value 100</p>
<p>[Slot 0 Opt. Card] Description of adapter card in option slot.</p>	<p>Parameter Numbers 5 Parameter Group Linear List Display Units None Parameter Type Read Only Linkable No Selections 0 "No Opt Instd"</p>
<p>[Software Version] Numeric value of software version.</p>	<p>Parameter Numbers: 1 Parameter Group: Configuration Parameter Type: Read Only Linkable No</p>
<p>[Startup State] Present state value of the startup procedure.</p>	<p>Parameter Numbers 3 Parameter Group Linear List Display Units None Parameter Type Read/Write Change While Running Yes Linkable No Minimum Value 0 Maximum Value 100 Default Value 1</p>
<p>[State] Present state of axis module; enabled/disabled.</p>	<p>Parameter Numbers 200, 201, 202, 203 Parameter Group Linear List Display Units None Parameter Type Read Only Linkable No Selections 0 "Disabled" 1 "Enabled"</p>
<p>[Status Display] Textual description of present status of drive.</p>	<p>Parameter Numbers 8 Parameter Group Linear List Display Units None Parameter Type Read Only Linkable No Selections 0 "Sys Faulted" 1 "Sys Wait Bus" 2 "Sys Bus Chrg" 3 "Sys Ready" 4 "Sys Enabled" 5 "Sys Stopping"</p>

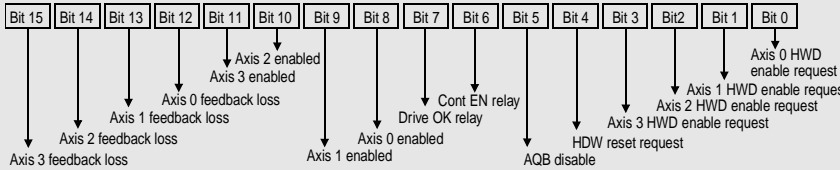
<p>[Stop Mode] Parameter to select whether the axis module should velocity command to zero (regen) or coast to a stop</p>	<p>Parameter Numbers 240, 241, 242, 243 Parameter Group Vel Cmd Data Display Units None Parameter Type Read/Write Change While Running Yes Linkable No Default Value 0 "Regen" Selections 0 "Regen" 1 "Coast"</p>
<p>[Stop Time Lim] Maximum amount of time that the module will remain enabled while trying to stop. Useful for very slow velocity rate change settings. Important: If hardware enables are used to stop the drive, circuitry only allows 0.5 seconds before disabling (independent of this parameter).</p>	<p>Parameter Numbers 384, 385, 386, 387 Parameter Group Vel Cmd Data Display Units secs Parameter Type Read/Write Change While Running Yes Linkable No Minimum Value 2 secs Maximum Value 120secs Default Value 2 secs</p>
<p>[Stopping Cur] During a regen stop, the amount of current available to stop the motor. (Only works when StopMode = Regen)</p>	<p>Parameter Numbers 308, 309, 310, 311 Parameter Group Vel Cmd Data Display Units amps Parameter Type Read/Write Change While Running Yes Linkable No Minimum Value 0% of rated motor current Maximum Value 300% of rated motor current Default Value 300% of rated motor current</p>
<p>[Sum On Days] Displays the total number of days that the drive has ever had control power applied</p>	<p>Parameter Numbers 95 Parameter Group Linear List Display Units None Parameter Type Read Only Linkable No</p>
<p>[Sum On Minutes] Display the total number of minutes that the drive has ever had control power applied.</p>	<p>Parameter Numbers 94 Parameter Group Linear List Display Units None Parameter Type Read Only Linkable No</p>
<p>[Sys I/O Image] Displays the processor image of these hardware signals.</p>	<p>Parameter Numbers 7 Parameter Group Linear List Parameter Type Read Only</p>  <p>The diagram shows a horizontal row of 16 boxes labeled Bit 15 through Bit 0. Arrows point from each bit to a corresponding hardware signal:</p> <ul style="list-style-type: none"> Bit 15: Axis 3 feedback loss Bit 14: Axis 2 feedback loss Bit 13: Axis 1 feedback loss Bit 12: Axis 0 feedback loss Bit 11: Axis 2 enabled Bit 10: Axis 3 enabled Bit 9: Axis 1 enabled Bit 8: Axis 0 enabled Bit 7: Drive OK relay Bit 6: Cont EN relay Bit 5: AQB disable Bit 4: HDW reset request Bit 3: Axis 3 HWD enable request Bit 2: Axis 2 HWD enable request Bit 1: Axis 1 HWD enable request Bit 0: Axis 0 HWD enable request

<p>[Sys Mod Data] Diagnostic information of data communicated between the controller and system module.</p>	<p>Parameter Numbers 6 Parameter Group Linear List Parameter Type Read Only</p>

<p>[Sys Mod Status 2] Diagnostic information of smart power systems.</p> <p>Active on all Smart Power 22 kW systems and 5 and 10 kW (Series C or later) systems</p> <p>1 = true Note: Warnings are set at 80% rating.</p>	<p>Parameter Numbers 38 Parameter Group Linear List Parameter Type Read Only</p>

<p>[System Type] Catalog number of System Module. Set during the initialization of the 1394.x-SJTxx-A system module.</p>	<p>Parameter Numbers 14 Parameter Group Configuration Display Units None Parameter Type Read Only Linkable No</p>							
	<table> <tr> <td>0</td> <td>"NOT PRESENT"</td> </tr> <tr> <td>1</td> <td>"1394.x-SJT05"</td> </tr> <tr> <td>2</td> <td>"1394.x-SJT10"</td> </tr> <tr> <td>3</td> <td>"1394-SJT22"</td> </tr> </table>	0	"NOT PRESENT"	1	"1394.x-SJT05"	2	"1394.x-SJT10"	3
0	"NOT PRESENT"							
1	"1394.x-SJT05"							
2	"1394.x-SJT10"							
3	"1394-SJT22"							

<p>[Test Mode Sel] Internal (factory) test mode selections.</p>	<p>Parameter Numbers 16 Parameter Group Linear List Display Units None Parameter Type Read/Write Change While Running Yes Linkable No Minimum Value 0 Maximum Value 32767 Default Value 0</p>
----------------------------------------------------------------------------	----------------------------------------------------------------------------------------------------------------------------------------------------------------------------------------------------------------------------------------------------------------------------------------------

[Torq Source]

Configures the source of the torque reference for the axis. Automatically changed when [Mode Sel] (parameter 112) is changed (for convenience during commissioning).

Parameter Numbers	360, 361, 362, 363		
Parameter Group	Torq Data		
Display Units	None		
Parameter Type	Read/Write		
Change While Running	Yes		
Linkable	No		
Default Value	0	"Vel Out"	
Selections	0	"Vel Out"	Axis is configured as a standard velocity commanded drive (velocity regulator output is the torque source). [Prop Gain Kp], [Intg Gain Ki], [Feed Fwd Gain], and [Droop] are active parameters.
	1	"Vel+DTrq+PLd"	Axis is configured as a standard velocity commanded drive with additional torque inputs. The additional inputs to the final torque summing node are the fixed [Cur Preload], and the dynamic [Dig Torq Ref] which can be linked to a real-time digital input (the velocity regulator output, the preload, and digital torque reference sum to become the torque source). [Prop Gain Kp], [Intg Gain Ki], [Feed Fwd Gain], [Droop], [Cur Preload] and [Dig Torq Ref] are active parameters.
	2	"Dig Torq"	Axis is configured as a digitally torque commanded drive. The dynamic [Dig Torq Ref] is meant to be linked to a real-time digital input. [Dig Torq Ref] is the active parameter.
	3	"Vel+ATrq+PLd"	Axis is configured as a standard velocity commanded drive with additional torque inputs. The additional inputs to the final torque summing node are the fixed [Cur Preload], and the real-time analog voltage from the torque inputs (TQREF+ and TQREF-). This analog voltage is sampled every 256µs; typical use is a torque feedforward input in a high performance position loop system. Gain is 3V/100% rated torque. Analog range is +10V (the velocity regulator output, the preload, and digital torque reference sum to become the torque source). [Prop Gain Kp], [Intg Gain Ki], [Feed Fwd Gain], [Droop], and [Cur Preload] are active parameters.
	4	"ATrq1+PLd"	Axis is configured as an analog torque commanded drive, with the fixed [Cur Preload] summed in. The real-time analog voltage from the torque inputs (TQREF+ and TQREF-) are utilized. This analog voltage is sampled every 256µs; typical use is a torque block for a tensioner, an external position or velocity controller, or as a torque follower. Gain is 3V/100% rated torque. Analog range is +10V. In this mode, [Cur Preload] is the active parameter.
	5	"ATrq2+PLd"	Identical to Mode 4, except that the analog torque inputs come from VREF+ and VREF- instead of TQREF+ and TQREF-.

<p>[Typ 1 Logic Axis] Configures which axes are affected by SCANport type 1 commands (Jog, Start, etc). All axes will always respond to a stop command.</p>	<p>Parameter Numbers 23 Parameter Group Setup Parameter Type Read/Write Change While Running No Linkable No Default Value 00001111</p>

<p>[Type 1 Status] This parameter displays status information about the system and the first [Typ 1 Logic Axis] (first axis with a bit set).</p>	<p>Parameter Numbers 17 Parameter Group Monitor Parm Parameter Type Read Only</p>

<p>[Type 2 Status] This parameter displays status information about the system and axis modules.</p>	<p>Parameter Numbers 18 Parameter Group Monitor Parm Parameter Type Read Only</p>

<p>[Units Sel] If set to "internal," drive units will be displayed on the HIM, instead of the default engineering "user" units.</p>	<p>Parameter Numbers 2 Parameter Group Linear List Display Units None Parameter Type Read/Write Change While Running Yes Linkable No Default Value 0 "User" Selections 0 "User" 1 "Internal"</p>
------------------------------------------------------------------------------------------------------------------------------------------------	----------------------------------------------------------------------------------------------------------------------------------------------------------------------------------------------------------------------------------------------------------------------------------------------------------------------------

<p>[Up To Spd Tol] Percentage of command velocity that feedback velocity must be within before asserting the "At Ref" bits in [Type 1/2 Status].</p>	<p>Parameter Numbers 248, 249, 250, 251 Parameter Group Vel Cmd Data Display Units % Parameter Type Read/Write Change While Running Yes Linkable No Minimum Value 0% Maximum Value 39% Default Value 3.90%</p>
-----------------------------------------------------------------------------------------------------------------------------------------------------------------	-----------------------------------------------------------------------------------------------------------------------------------------------------------------------------------------------------------------------------------------------------------------------------------------------------------------------

<p>[Enble Input Mode] This parameter specifies whether the hardware enable signals are used on the wiring board for input. If configured as Not Used, the HIM or SCANport device will provide the enable signal for the axis.</p>	<p>Parameter Numbers 24 Parameter Group Setup Display Units None Parameter Type Read/Write Change While Running Yes Linkable No Default Value 0 "Used" Selections 0 "Used" 1 "Not Used"</p>
<p>[Vel Command] Present velocity command for the axis (after all limiting has occurred).</p>	<p>Parameter Numbers 220, 221, 222, 223 Parameter Group Monitor Parmns, Vel Cmd Data Display Units rpm Parameter Type Read Only Linkable No</p>
<p>[Vel Damp Sel] This parameter is associated with the auto tune function and specifies the velocity damping desired by the user. The auto tuning procedure calculates a new set of Velocity Loop Gains and a new Current Rate Limit when the user initiates the Auto Tune Calculate function.</p>	<p>Parameter Numbers 256, 257, 258, 259 Parameter Group ATune Config Display Units None Parameter Type Read/Write Change While Running Yes Linkable No Default Value 0 "Zeta=0.87" Selections 0 "Zeta=0.87" <i>Underdamped</i> 1 "Zeta=1.00" <i>Critically Damped</i> 2 "Zeta=0.70" <i>Underdamped</i> 3 "Zeta=1.40" <i>Overdamped</i></p>
<p>[Vel Feedback] Present velocity feedback for the axis (after all filtering has occurred).</p>	<p>Parameter Numbers 224, 225, 226, 227 Parameter Group Monitor Parmns, Vel Cmd Data Display Units rpm Parameter Type Read Only Linkable No</p>
<p>[Vel Lim] This parameter automatically changes both [CW/CCW Vel Lim] to the same value. (for convenience during commissioning).</p>	<p>Parameter Numbers 120, 121, 122, 123 Parameter Group Velocity Cmd Data Display Units rpm Parameter Type Read/Write Change While Running Yes Linkable No Minimum Value 0.0 rpm Maximum Value 8000.0 rpm Default Value This is determined by the motor catalog number.</p>
<p>[Vel LowPas BW] Specifies the single pole low pass velocity feedback filter bandwidth. A value of 0 disables the filter.</p>	<p>Parameter Numbers 140, 141, 142, 143 Parameter Group Vel Loop Tune Display Units Hz Parameter Type Read/Write Change While Running Yes Linkable No Minimum Value 0 Hz Maximum Value 1500 Hz Default Value 0 Hz</p>

<p>[Vel Rate Lim] The rate at which a velocity command is incremented or decremented per unit of accel/ decel time (in seconds). Important: The velocity rate limit command overrides a position controller velocity rate limit command. This parameter is automatically changed to its maximum value when [Motor Type] is selected.</p>	<p>Parameter Numbers 136, 137, 138, 139 Parameter Group Vel Cmd Data Display Units rpSS (revolutions/second/second) Parameter Type Read/Write Change While Running Yes Linkable No Minimum Value 0 rpSS Maximum Value 34015 rpSS Default Value 34015 rpSS</p>
<p>[Vel Ref Fract] Lower 16 bits of [Vel Ref Whole] (parameter 204), forming a 32 bit velocity reference.</p>	<p>Parameter Numbers 208, 209, 210, 211 Parameter Group Linear List Display Units rpm Parameter Type Read/Write Linkable Yes</p>
<p>[Vel Ref Whole] This parameter is the present value of digital velocity reference and must be the destination of link for any data to be output.</p>	<p>Parameter Numbers 204, 205, 206, 207 Parameter Group Vel Cmd Data Display Units rpm Parameter Type Read/Write Linkable Yes Minimum Value -8000.0 rpm Maximum Value +8000.0 rpm Default Value 0.0 rpm</p>
<p>[Vel Source] Selects the velocity command source(s) within the drive. Automatically changed when [Mode Sel] is changed (for convenience during commissioning). For Example: Axis 0, 1, 2 could be set in (#0) analog reference while axis 3 could be set in (#1) digital input.</p>	<p>Parameter Numbers 364, 365, 366, 367 Parameter Group Vel Cmd Data Display Units None Parameter Type Read/Write Change While Running Yes Linkable No Default Value 0 "Anlg Vel" Selections 0 "Anlg Vel" analog ref from [Vel Command] (parameter 220) 1 "Dig Vel" internal digital reference [Vel Ref Whole/Fract] (204, 208) 2 "Anlg+Dig Vel" analog and digital reference 3 "Zero Vel" zero velocity reference</p>

1394 Analog Servo Software Diagrams

The following diagrams describe the control loops of the 1394 analog servo system.

Figure 8.1
1394 Analog Servo Software Diagram (part 1)

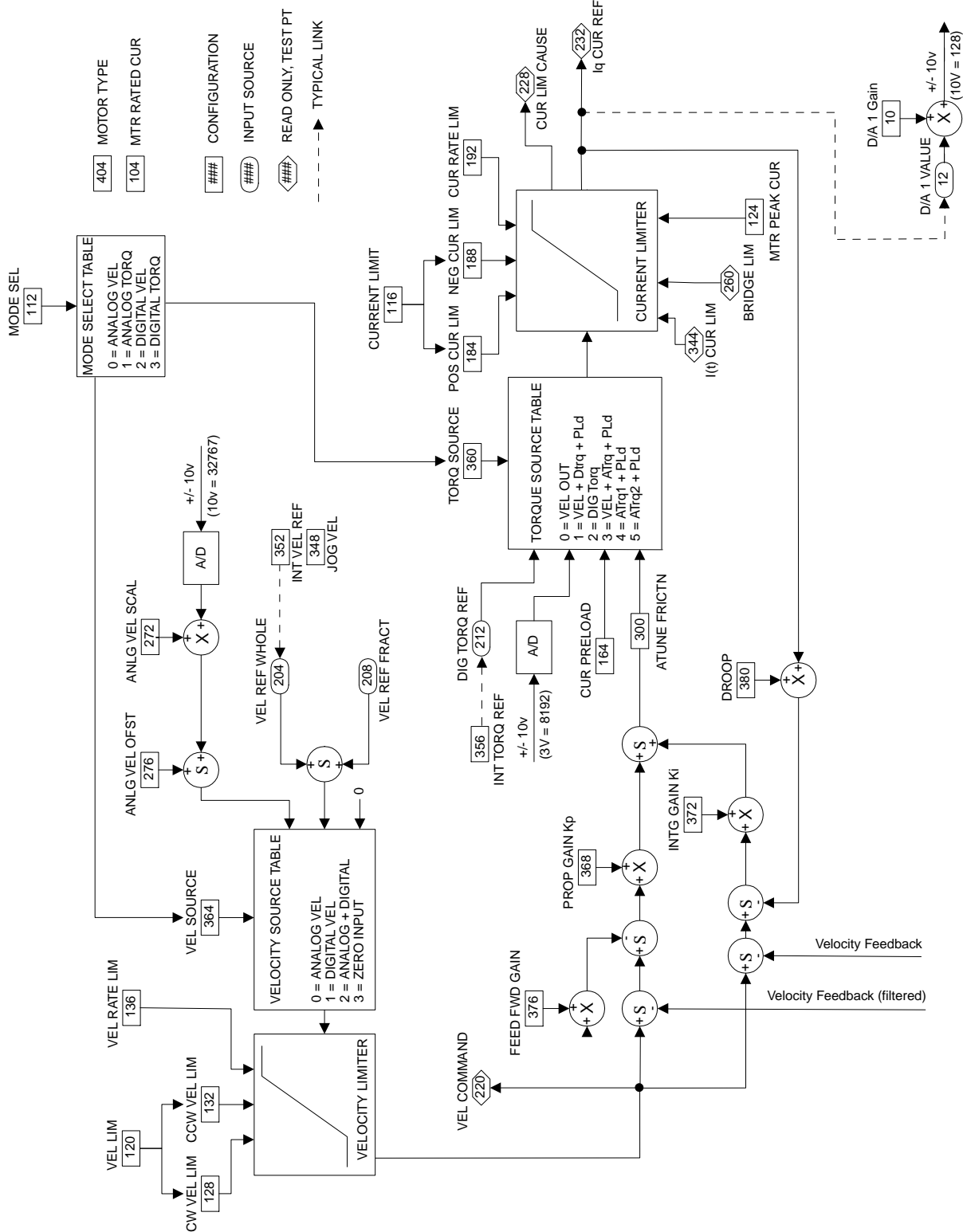
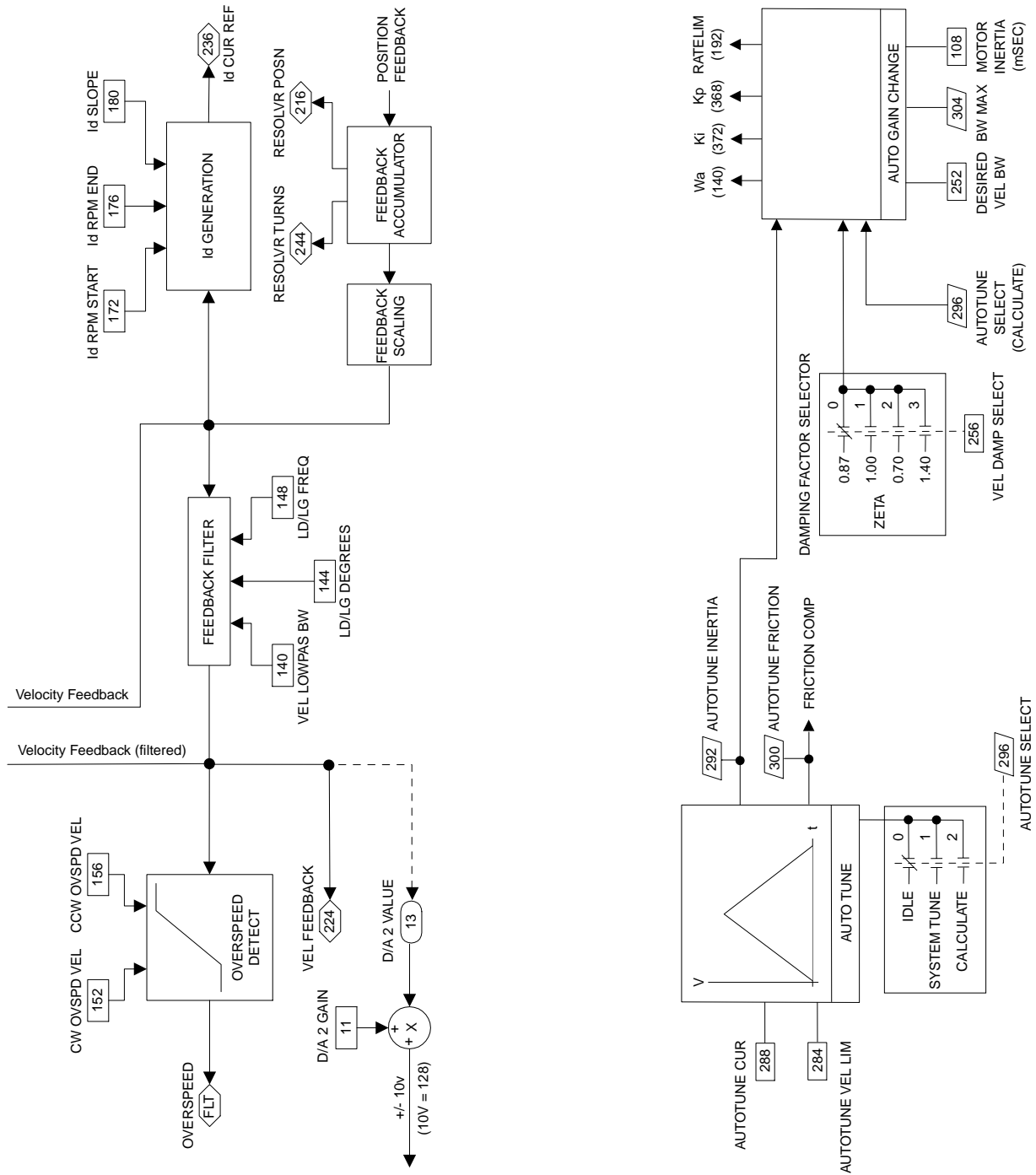

Figure 8.2
1394 Analog Servo Software Diagram (part 2)



Troubleshooting

Chapter Objectives

This chapter covers:

- Understanding how to detect a problem
- Understanding system and axis module LEDs
- Understanding system faults
- Understanding GMC Turbo and GMC controller faults
- Understanding Analog Servo system module faults
- Troubleshooting general system problems
- Replacing system and axis modules
- Checking for a blown fuse in the 1394-DCLM
- Replacing 1394 the shunt module fuse
- Replacing the AM50 and AM75 axis module fan



ATTENTION: This product contains stored energy devices. To avoid hazard of electrical shock, verify that all voltage on the capacitors has been discharged before attempting to service, repair, or remove this unit. You should only attempt the procedures in this chapter if you are qualified to do so and familiar with solid-state control equipment and the safety procedures in publication NFPA 70E.

ATTENTION: Do not attempt to defeat or override the drive fault circuits. You must determine the cause of a fault and correct it before you attempt to operate the system. If you do not correct a drive or system malfunction, it could result in personal injury and/or damage to equipment as a result of uncontrolled machine system operation.

ATTENTION: If you use an oscilloscope (or chart recorder) for troubleshooting, you must properly ground it. The oscilloscope chassis can be at a potentially fatal voltage if you do not properly ground it. Always connect the oscilloscope chassis to an earth ground.

Understanding How to Detect a Problem

When a drive fault occurs, the LED on the front panel changes and a fault message appears.

The majority of 1394 faults cause the DROK contact to operate. If a drive fault occurs, you can reset the fault detection circuitry by removing and reapplying power. However, if it is a hardware fault, you need to correct the fault before restarting.

This material, along with the diagnostic/troubleshooting information included with the position controller, will help you identify most common system malfunctions and determine which module that problem pertains to.

Understanding System and Axis Module LEDs

The system module and each axis module has one LED visible from the front of the module. The LEDs are labeled "Status" on all axis modules and "Status" for GMC, Analog Servo, and 9/440 versions and "I/O Ring Status" for the CNC Interface system. They indicate status as follows:

For this module:	For this LED:	Status of the LED:	Potential Cause:	Possible resolution:
GMC Turbo, GMC or Analog Servo System Module	Status	Steady red	Malfunctioning system module.	<ul style="list-style-type: none"> • Verify wiring. • Secure wiring connections. • Replace the module. • Contact your local Allen-Bradley Support Representative.
		Flashing red	A fault has occurred in system.	<ul style="list-style-type: none"> • Verify wiring. • Secure wiring connections.
		Alternating red and green	DC bus is not up.	<ul style="list-style-type: none"> • Apply three-phase power. • Check DC bus LED.
			Open fuse or malfunctioning contactor on user-supplied 3 phase input.	<ul style="list-style-type: none"> • Check wiring to start/stop circuitry. • Check fuse.
			Malfunctioning system module.	Replace the module.
		Steady green	The bus is up and axes are enabled.	None needed.
		Flashing green	The bus is up, but no axis is enabled (Analog Servo only).	<ul style="list-style-type: none"> • Check axes and enable them, if necessary. • Verify that enable wiring is correct and not open.
			Enable signal from position controller is not present (Analog Servo only).	<ul style="list-style-type: none"> • Check axes and enable them, if necessary. • Verify that enable wiring is correct and not open. • Check connections on input wiring board.
			Position controller has detected a machine system malfunction and will not enable the 1394 (Analog Servo only).	<ul style="list-style-type: none"> • Check position controller. • Check the machine. • Check the enable status at the Analog Servo wiring board.
			System enable is not powered (GMC only).	<ul style="list-style-type: none"> • Check the enable status. • Check for 24V DC on system enable signal, TB1 and TB2 (refer to the chapter <i>Wiring 1394 GMC and GMC Turbo Systems</i>, Figure 4.1 and Figure 4.2).
Not illuminated	There is no power to the system module.	Check the power supply to the system module.		

For this module:	For this LED:	Status of the LED:	Potential Cause:	Possible resolution:
CNC Interface System Module	I/O Ring Status	Steady red	The fiber optic ring has failed at some point before the 1394 system module.	Check all components and connections before the 1394 on the fiber optic ring.
		Flashing red	The fiber optic ring has failed at some point after the 1394 system module.	Check all components and connections after the 1394 on the fiber optic ring.
		Not illuminated	No power to the system. This LED is not illuminated when operating normally.	Check 24V control power and 460V AC input power for the 1394.
9/440 System Module	XILINX	Steady red	Operating normally.	None needed.
		Not illuminated	Power to the system module is not on.	<ul style="list-style-type: none"> • Cycle power. • Apply power to the system module.
			An XILINX hardware fault has occurred.	<ul style="list-style-type: none"> • Replace the system module. • Contact your local Allen-Bradley Support Representative.
	WATCHDOG	Steady red	Operating normally.	None needed.
		Not illuminated	Power to the system module is not on.	Apply power to the system module.
			Watchdog has timed out and a processor failure has occurred.	<ul style="list-style-type: none"> • Cycle power. • Replace the system module. • Contact your local Allen-Bradley Support Representative.
	Status	Steady red	Operating normally.	None needed.
		Not illuminated	Power to the system module is not on.	Apply power to the system module.
			Watchdog has timed out and a processor failure has occurred.	<ul style="list-style-type: none"> • Cycle power. • Replace the system module. • Contact your local Allen-Bradley Support Representative.
	R-I/O	Steady or flashing red	For systems with remote I/O, this indicates that communication with remote I/O is occurring.	None needed.
		Not illuminated	Your system does not have remote I/O or you have not enabled remote I/O in your program.	<ul style="list-style-type: none"> • Verify that you have purchased the remote I/O option for this system. • Verify that you have enabled the remote I/O in your PAL program.

For this module:	For this LED:	Status of the LED:	Potential Cause:	Possible resolution:
Axis Module	Status	Steady red	Malfunctioning axis module.	<ul style="list-style-type: none"> • Verify wiring. • Verify that the slider and terminator are securely engaged. • Secure wiring connections. • Replace the module.
		Flashing red	Axis fault has occurred.	<ul style="list-style-type: none"> • Verify wiring. • Secure wiring connections. • Check fault status on the HIM (Analog Servo only), in GML (GMC only), or on the operator panel (CNC Interface and 9/440). • Check 460V AC input power. • Check axis status on the HIM (Analog Servo only), in GML (GMC only), and on the operator panel (CNC Interface and 9/440)
		Alternating red and green	DC bus is not up.	<ul style="list-style-type: none"> • Check the system module's LED. • Check slider connections to verify that they are properly seated. • Verify that the terminator is present on the last axis.
		Flashing green	Axis is not enabled.	<ul style="list-style-type: none"> • Check axes and enable them, if necessary. • Verify that enable wiring is correct and not open.
			Enable signal from position controller is not present (Analog Servo only).	<ul style="list-style-type: none"> • Check axes and enable them, if necessary. • Verify that enable wiring is correct and not open.
			Incorrect wiring or loose connections.	Check connections on the input wiring board.
			Axis setups may not be correct for the application.	<ul style="list-style-type: none"> • Verify that axis definitions are correct. • Check tuning parameters.
		Not illuminated	There is no power to the axis module.	Verify that the terminator is present on the last axis.
There is no power to the system.	<ul style="list-style-type: none"> • Verify that the terminator is present on the last axis. • Check system module power supply. 			

Understanding System Faults

Depending on which 1394 system you are using, your faults will be displayed differently.

For this system module:	This is where faults appear:	This is where to look for additional fault information:
GMC Turbo or GMC	In GML in the Online Manager or Watch window.	The <i>GML Programming Manual V3.7</i> or greater (publication 999-104) or the <i>GML Commander Reference Manual</i> (publication GMLC-5.2).
CNC Interface	On the 9/Series operator panel.	<i>The 9/Series Integration and Maintenance Manual</i> (publication 8520-6.2).
Analog Servo	On the HIM.	The <i>Finding Analog Servo System Faults</i> section of this chapter.
9/440	On the operator 9/Series panel.	<i>The 9/Series Integration and Maintenance Manual</i> (publication 8520-6.2).

Finding GMC Faults

To examine the fault status of the system or axis modules for the GMC version, you can:

- View instantaneous status
- View constant status

Viewing Instantaneous Status

You can look at the status of a particular variable within GML at a particular point in time. To look at a status:

1. Open GML. The GML window appears.
2. Select **Diagram** from the menu bar. The Diagram menu appears.
3. Select **Online**. The Online Manager window appears.
4. In the *Axis* area, select the axis you want to see status on.
5. In the area above the *Axis* area, select the variable for which you want to see status.

Note: For example, select the *Global Fault* variable to determine which system fault has occurred.

6. Select **Examine**. Information about that variable appears in the box on the bottom of the Online Manager window.

Viewing Continuous Status

When you use the Watch feature, a window appears within the Online Manager window showing the variables you selected. GML constantly updates the status of those variables as they change.

To view continuous status:

1. Open GML. The GML window appears.
2. Select **Definitions** from the menu bar. The Definitions menu appears.
3. Select **Watch Items**. The Watch Items window appears.
4. Select any variables that you want to watch from the *Defined Items* area and click on **Add**. Those items appear in the *Items to Watch* area.
5. Click on **Save**. The GML window appears.
6. Select **Diagram** from the menu bar. The Diagram menu appears.
7. Select **Online**. The Online Manager window appears.
8. On the top right of the window, select the **Watch**. A message box appears. The variables that you selected and their status appear in this window.

Refer to the *Expression Builder* chapter of the *GML Programming Manual V3.7 (or above)* for a list of fault and status variables.

Finding Analog Servo System Faults

When a fault occurs for the Analog Servo version, a fault message appears on the HIM.

Figure 9.1
HIM Fault Display

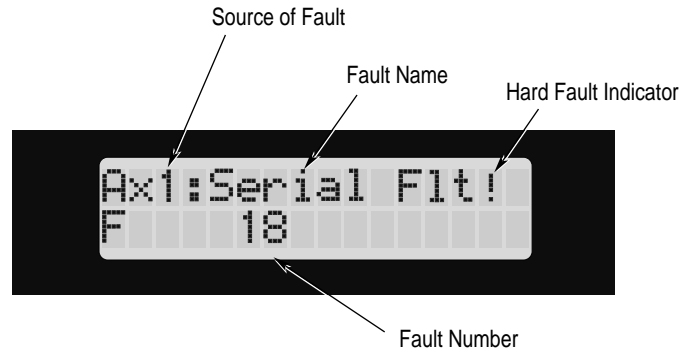

Each area on the diagram in Figure 9.1 has a significance:

In this area:	This information appears:
Source of fault	The area in which the fault originated: Ax0 = Axis module 0 Ax1 = Axis module 1 Ax2 = Axis module 2 Ax3 = Axis module 3 Sys = System module CPU = The host CPU (hardware) DSP = DSP CPU (hardware) Cus. = User action is the source of the fault Hdw. = Drive hardware is the source of the fault
Fault name	An abbreviated message indicating a particular fault.
Hard fault indicator	If an exclamation point appears in this location, a hard fault has occurred. You need to cycle drive power to clear this type of fault.
Fault number	The number associated with the particular fault.

Finding 9/440 Faults

Faults for the 9/440 appear on the second line of the operator panel. There is also an error log that contains the most recent system faults. To get to this error log screen:

1. At the main menu, press the continue softkey. The softkey menu changes.
2. Press the {ERROR MESSAGE} softkey. The error message screen appears.

For more information on 9/440 system faults refer to the *9/Series Integration and Maintenance Manual* (catalog 8520-6.2).

Finding CNC Interface Faults

Faults for the CNC Interface appear on the second line of the operator panel. There is also an error log that contains the most recent system faults. To get to this error log screen:

1. At the main menu, press the continue softkey. The softkey menu changes.
2. Press the {ERROR MESSAGE} softkey. The error message screen appears.

For more information on 9/Series system faults refer to the *9/Series Integration and Maintenance Manual* (catalog 8520-6.2).

Understanding GMC Turbo and GMC Controller Faults

Use the table below to identify the GMC and GMC Turbo Controller faults. The status LEDs are located inside the system module in the upper left corner. The figure below shows a picture of the LEDs.

Figure 9.2
GMC Turbo and GMC Status LEDs

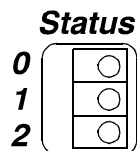

LED Status:				Potential cause:	Possible resolutions:
0:	1:	2:	Type:		
Off	Off	Off	Solid	Controller OK - no faults	N/A
On	Off	Off	Solid	Memory fault - Setup or program checksum error	Re-Download the GML diagram with the setups Reset the controller.
Off	On	Off	Solid	1394 Initialization failure	Reset the controller. If problem persists, return controller to the factory for repair.
On	On	Off	Solid	AxisLink initialization failure	Reset the controller. If problem persists, return controller to the factory for repair.
Off	Off	On	Solid	RIO interface initialization failure	Reset the controller. If problem persists, return controller to the factory for repair.
On	Off	On	Solid	Flex I/O initialization failure	Reset the controller. If problem persists, return controller to the factory for repair.
Off	On	On	Solid	Interrupt initialization failure	Reset the controller. If problem persists, return controller to the factory for repair.
On	On	On	Solid	DSP or initialization failure	Reset the controller. If problem persists, return controller to the factory for repair.
On	Off	Off	Flashing - fast ¹	DRAM test #1 failed	Return the controller to the factory for repair.
Off	On	Off	Flashing - fast ¹	DRAM test #2 failed	Return the controller to the factory for repair.
On	On	Off	Flashing -fast ¹	DRAM test #3 failed	Return the controller to the factory for repair.
Off	Off	On	Flashing - fast ¹	Applications memory functionality test failed	Return the controller to the factory for repair.
On	Off	On	Flashing - fast ¹	Setup memory functionality test failed	Return the controller to the factory for repair.
Off	On	On	Flashing - fast ¹	Dual port test #1 failed	Return the controller to the factory for repair.
On	On	On	Flashing - fast ¹	Dual port test #2 failed	Return the controller to the factory for repair.
On	Off	Off	Flashing - slow ¹	Serial port test failed	Return the controller to the factory for repair.
Off	On	Off	Flashing - slow ¹	Timer test failed	Return the controller to the factory for repair.
On	On	Off	Flashing - slow ¹	Initialization test failed	Return the controller to the factory for repair.
Off	Off	On	Flashing - slow ¹	Auxiliary I/O test failed	Return the controller to the factory for repair.
On	Off	On	Flashing - slow ¹	CXIC failed	Return the controller to the factory for repair.
Off	On	On	Flashing - slow ¹	DRAM test failed	Return the controller to the factory for repair.
On	On	On	Flashing - slow ¹	Transfer system failed	Return the controller to the factory for repair.

¹ Flashing slow is twice per second, flashing fast is ten times per second.

Understanding Analog Servo System Module Faults

The faults that apply to the Analog Servo System's system module appear in the following tables.

Note: Although these faults are for the Analog Servo version, in many instances, the descriptions, causes, and resolutions can also apply to the GMC version. The fault messages, however, would be different. Refer to the *GML Programming Manual* (publication 999-104) for more information.

Fault Message:	Description:	Potential cause:	Possible resolutions:
Bus Config	The configured bus voltage mode does not match the hardware.	The system module detected an incorrect shunt module configuration (wrong shunt installed).	<ul style="list-style-type: none"> Verify that the shunt module is rated for and compatible with your system module.
		Custom shunt parameters exceed the system module shunt limits.	<ul style="list-style-type: none"> Verify custom shunt parameters do not exceed the system module limitations.
Bus Low Vlt	The DC power bus activates undervoltage limit when the bus drops to 275V DC or less. It will clear at 300V DC.	The voltage on the 360/480V AC input power is low.	Verify incoming AC voltage and change the supply source, if needed.
Bus Ovr Vlt	<p>The DC Power Bus is continuously monitored. If it exceeds a preset level (810V DC), a fault is sensed and the power supply is disabled.</p> <p>Bus Voltage Operation Shunt turns on at 800V DC Shunt turns off at 750V DC Over voltage trip point 810V DC Under voltage trip point 275V DC Under voltage fault clears at 300V DC</p>	If this fault occurs when you power up the system module with the M-contactor, the power distribution impedance might be stiff or line voltage might be too high.	<ul style="list-style-type: none"> Perform line conditioning. Verify that line voltage is within specifications.
		The position controller acceleration / deceleration rate is incorrectly set.	Change the command profile to reduce speed or increase time.
		The system inertia is too high causing excessive energy to be returned to the power supply bus.	<ul style="list-style-type: none"> Change the command profile to reduce speed or increase time. Use a larger external shunt resistor.
		A vertical axis with insufficient counterbalancing is overdriving the servo motor and causing excessive energy to be returned to the power supply bus.	<ul style="list-style-type: none"> Use the external shunt resistor. Increase the mechanical counter-balance on the machine.
		Input line voltage exceeds the maximum input voltage rating.	Verify incoming 360/480V AC input voltage and change the supply source, if needed.
		Power Driver Board is malfunctioning and is incorrectly sensing the bus voltage.	Replace the system module.
		The shunt regulator or transistor has malfunctioned.	Replace the system module.
External shunt regulator fuse has blown.	Check and possibly replace the shunt resistor.		
CAN Hdwr	SCANport hardware error detected.	The SCANport device or cable is faulty.	Check SCANport connections.
Cntctr Flt	Three-phase power is either detected when it shouldn't be or not detected when it should be.	The contactor is welded or failed to open.	<ul style="list-style-type: none"> Correct wiring. Replace the contactor.
		The input wiring to your contactor is incorrect.	Correct wiring.
Cur Limit	The system module has reach its current limit.	The motoring/regenerative current produced by the motor(s) and axis module(s) exceeds the current limit allowed by the system module.	<ul style="list-style-type: none"> Increase system module size. The sum of the axis modules continuous current exceeds the system module current limit rating.

Fault Message:	Description:	Potential cause:	Possible resolutions:
Ground Flt	The system generates a ground fault when there is an imbalance in the DC bus of greater than 50A.	Incorrect wiring.	<ul style="list-style-type: none"> • Verify motor and ground wiring. • Replace cables.
		Motor malfunction.	Check the resistance of each motor winding phase to case ground with an ohm meter. Readings should be in mega ohms.
		Axis Module IGBT malfunction.	Replace the axis module.
		Short to ground.	<ul style="list-style-type: none"> • Replace the system or axis module. • Check grounding and incoming power wiring.
Hdwr Fault!	Control hardware fault detected.	Terminator is not installed.	Check slider connections/termination strip.
		The system module is bad.	Replace the system module.
Memory!	Hardware memory error detected.	CPU memory has failed.	<ul style="list-style-type: none"> • Verify that EEproms are seated properly. • Replace the system module.
NV Memory!	Non-volatile memory is corrupt.	A checksum failure has occurred on the personality module.	<ul style="list-style-type: none"> • Reset and save defaults. • Replace personality module. • Replace system module.
Ovr temp	The 1394 contains a thermal sensor which senses the internal ambient temperature.	The fan on the system module or an axis module failed.	Replace the system or axis module.
		The cabinet ambient temperature is above rating.	Check the cabinet temperature.
		The machine duty cycle requires an RMS current exceeding the continuous rating of the controller.	Change the command profile to reduce speed or increase time.
		The airflow access to the 1394 is limited or blocked.	Check airflow and re-route cables away from the 1394.
Phase Loss	The three-phase input line is monitored and a fault will be issued whenever a phase loss is detected.	One or more input line fuses have opened.	Check fuses and replace, as necessary.
		Input line contactor malfunction.	<ul style="list-style-type: none"> • Correct wiring. • Replace contactor.
		Incorrect wiring.	Check 360/480V AC input power at system module.
Pre Charge	The bus voltage did not rise fast enough during the pre-charge state.	Short detected on the DC bus.	<ul style="list-style-type: none"> • Check for shorts on the DC bus.
		Axis enabled before the pre-charge checking has cleared.	<ul style="list-style-type: none"> • Verify that all phases are functioning properly.
		Commanding torque to axis before full bus voltage is reached.	<ul style="list-style-type: none"> • Verify the axis is not enabled before the full 3-phase bus power is up.
Serial Flt!	Serial communications lost.	If the message contains "CUS," communications were lost to the SCANport device.	Verify that SCANport device is connected.
		If the message contains "Axis," "Sys," or "HDW," communications were lost.	<ul style="list-style-type: none"> • Check the system's terminator. • Check the slider. • Verify [Shunt R] parameter value
Sftwr Flt!	Software error detected.	A programming error was made.	Reset drive.
Shunt TmOut	The shunt resistor has timed out.	The regenerative energy produced by the motor exceeded the limit of the shunt resistor.	<ul style="list-style-type: none"> • Use a properly sized shunt or modify duty cycle of the application. • System uses internal shunt and requires external shunt for additional capacity.
Unknown Flt!	Fault is detected but source is unknown.	Wrong version of software for the hardware or loose internal or external connection.	<ul style="list-style-type: none"> • Check system terminator. • Reset drive.
Unkn Module!	A module unknown to this version of software is present.	Wrong version of software for the firmware.	<ul style="list-style-type: none"> • Obtain firmware that supports new module type. • Check slider terminations. • Contact Allen-Bradley. Check software version in system module.

Understanding Analog Servo System Axis Faults

The faults that apply to the Analog Servo System's axis module appear in the following table.

Fault Message:	Description:	Potential Cause:	Possible resolution:
ATune Fault	The auto tune cycle has exceeded two seconds.	Motor is disconnected or not able to turn.	Connect the motor.
		Motor power/resolver wiring is open or improperly wired.	Check motor power/resolver wiring.
		Axis enable has not been applied within 60 seconds of fault during auto tune.	<ul style="list-style-type: none"> • Increase the auto tune current limit to increase motor torque. • Decrease the auto tune velocity to decrease the auto tune cycle time. You must apply the enable signal within 60 seconds during auto tune.
Bus Loss	The DC bus supply to the axis module was lost.	The slider connections may not be secure.	Check slider connections/termination strip.
		An axis module's bus link fuse has blown.	Replace the module.
Ring Write!	The axis module is not set to proper scaling.	The slider connections may not be secure.	Check slider connections/termination strip.
		The axis module is malfunctioning.	<ul style="list-style-type: none"> • Terminate signal common (TB1-19) to chassis (PE) ground. • Replace the module.
Fdbck Loss (Resolver)	The resolver wiring is open, shorted, or missing.	Open or short circuit has occurred on resolver wiring.	Check the resolver cable connectors/wiring to the system module and motor.
		The resolver wiring or termination to system module is incorrect.	Check the resolver cable connectors/wiring to the system module and motor.
		The motor resolver might be bad.	Replace the motor resolver.
I(t) Fault	The output current is exceeding the time-current rating.	Accel/decel command from position controller is requiring peak current for an excessive amount of time.	Change the command profile to reduce speed or increase time.
		The machine friction, inertial load, and/or viscous load is excessive.	<ul style="list-style-type: none"> • Change the command profile to reduce speed or increase time. • Check for mechanical problems on the machine.
		The motor has been improperly sized.	<ul style="list-style-type: none"> • Check motor size for your application. • Contact your Allen-Bradley Support Representative.
		A short circuit exists across the drive output terminals.	Check wiring between the axis and the motor.
		Logic supply circuits have malfunctioned or AC output is incorrectly wired.	<ul style="list-style-type: none"> • Check wiring between the axis and the motor. • Check power wiring between the axis and the motor. • Check resolver wiring between the system module and the motor.
Ovr Speed	Motor velocity exceeded the overspeed trip limit.	Motor velocity has exceeded the overspeed value.	<ul style="list-style-type: none"> • Verify operating parameters. • Verify application requirements.
Ovr temp	The 1394 contains a thermal sensor that senses the internal ambient temperature.	The cabinet's ambient temperature is above rating.	Check the cabinet temperature
		The machine's duty cycle requires an RMS current exceeding the continuous rating of the controller.	Change the command profile to reduce speed or increase time.
		The airflow access to the 1394 is limited or blocked.	Check airflow and re-route cables away from the 1394.

Fault Message:	Description:	Potential Cause:	Possible resolution:
Power Fault	The current through any one of the power IGBTs has exceeded 300% if the 1394's current rating.	The motor lead has shorted	<ul style="list-style-type: none"> • Check the motor cable. • Check the resistance of each power phase wire to ground. It should be in Mega ohms. • Make sure ferrite cores are not installed on motor power conductors.
		The motor is malfunctioning	<ul style="list-style-type: none"> • Check the resistance of each motor winding phase to case ground with an ohm meter. Readings should be in Mega ohms. • Return motor for repairs.
		Power IGBTs are malfunctioning.	Replace the axis module.
PwrOn Enable	During active fault reset, an axis was enabled before system power-up.	An axis hardware enable input was active during system control power on or during fault reset.	Verify that axis is not enabled before power is applied.

Troubleshooting General System Problems

The tables that follow provide potential conditions that could occur with your system and recommends possible resolutions to those conditions.

Condition:	Potential cause:	Possible resolution:
Axis or System runs uncontrollably	The velocity feedback, position feedback device, or velocity command signal wiring is incorrect or open.	Check wiring.
	Unintentionally in torque mode.	Check to see what mode was programmed.
	An internal malfunction exists.	Replace system or axis module.
Axis or System is unstable	[Prop Gain Kp, Intg Gain Ki, Feed Fwd Gain] parameters (368, 372, 376 (Analog Servo only)) are set too high.	Run auto tune.
	Position loop gain or position controller accel/decel rate is improperly set.	Run auto tune.
	Improper grounding or shielding techniques are causing noise to be transmitted into the position feedback or velocity command lines, causing erratic axis movement.	Check wiring and ground.
	[Motor Type] parameter (100 (Analog Servo only)) is incorrectly set (servo motor is not matched to 1394).	<ul style="list-style-type: none"> • Check setups. • Run auto tune.
You cannot obtain the motor acceleration/ deceleration that you want	[Pos Cur Lim, Neg Cur Lim] parameters (184, 188 (Analog Servo only)) are set too low.	Verify that current limits are set properly.
	[Motor Type] parameter (100 (Analog Servo only)) is incorrectly set (Analog Servomotor is not matched to 1394).	Program the correct motor and run auto tune again.
	The system inertia is excessive.	<ul style="list-style-type: none"> • Check motor size vs. application need. • Review servo system sizing.
	The system friction torque is excessive.	Check motor size vs. application need.
	Available current is insufficient to supply the correct accel/decel rate.	<ul style="list-style-type: none"> • Check motor size vs. application need. • Review servo system sizing.
	[Vel Rate Lim] parameter (136 (Analog Servo only)) is incorrect.	Verify that the parameters are set correctly and correct them, as necessary.
	[CW, CCW Vel Lim] parameters (128, 132 (Analog Servo only)) are incorrect.	Verify that the parameters are set correctly and correct them, as necessary.
[Anlg Vel Scal] parameter (272 (Analog Servo only)) is incorrect.	Verify that the parameters are set correctly and correct them, as necessary.	

Condition:	Potential cause:	Possible resolution:
Motor does not respond to a Velocity Command	Check for possible faults.	Verify that the parameters are set correctly and correct them, as necessary.
	The axis cannot be enabled for 1.5 seconds after disabling.	Disable the axis, wait for 1.5 seconds, and enable the axis.
	Enable signal has not been applied or the enable wiring is incorrect.	<ul style="list-style-type: none"> • Check the controller. • Check the wiring.
	The motor wiring is open.	Check the wiring.
	The motor thermal overload has tripped.	<ul style="list-style-type: none"> • Check for a fault. • Check the wiring.
	The motor has malfunctioned.	Repair or replace the motor.
	The coupling between motor and machine has broken (i.e., the motor moves, but the load/machine doesn't).	Check and correct the mechanics.
	[Vel Source] parameter (364 (Analog Servo only)) is set incorrectly.	Check and properly set the parameter.
	[Torq Source] parameter (360 (Analog Servo only)) is set incorrectly.	Check and properly set the parameter.
	[CW, CCW VEL Lim] parameters (128, 132 (Analog Servo only)) are set incorrectly.	Check and properly set the parameter.
The axis module has a malfunction.	Replace the axis module.	
Presence of noise on Command or resolver signal wires	Recommended grounding per installation instructions and Appendix B has not been followed.	<ul style="list-style-type: none"> • Verify grounding. • Route wire away from noise sources.
	External 50/60 Hz line frequency may be present.	<ul style="list-style-type: none"> • Verify grounding. • Route wire away from noise sources.
	External 100/120 Hz from a single phase logic supply may be present.	<ul style="list-style-type: none"> • Verify grounding. • Route wire away from noise sources.
	External 180 or 360 Hz from other adjustable speed drives may be present.	<ul style="list-style-type: none"> • Verify grounding. • Route wire away from noise sources.
	Variable frequency may be velocity feedback ripple or a disturbance caused by gear teeth or ballscrew balls etc. The frequency may be a multiple of the motor power transmission components or ballscrew speeds resulting in velocity disturbance.	<ul style="list-style-type: none"> • Decouple the motor for verification. • Check and improve mechanical performance of the gearbox, ballscrew, etc.

Condition:	Possible cause:	Possible resolution:
No Rotation	The motor connections are loose or open.	Check motor wiring and connections.
	Foreign matter is lodged in the motor.	Remove foreign matter.
	The motor load is excessive.	Size the servo system.
	The bearings are worn.	Return the motor for repair.
	The motor brake is engaged (if supplied).	<ul style="list-style-type: none"> • Check brake wiring and function. • Return the motor for repair.
	The motor is not connect to the load.	Check coupling.
Overheating	The duty cycle is excessive.	Change the command profile to reduce accel/decel or increase time.
	The rotor is partially demagnetized causing excessive motor current.	Return the motor for repair.
Abnormal Noise	[Prop Gain Kp, Intg Gain Ki, Feed Fwd Gain] parameters (368, 372, 376 (Analog Servo only)) are set too high.	Run auto tune again.
	Loose parts are present in the motor.	<ul style="list-style-type: none"> • Remove the loose parts. • Return motor for repair. • Replace motor.
	Through bolts are loose.	Tighten bolts.
	The bearings are worn.	Return motor for repair.
Erratic Operation - Motor locks into position, runs without control or with reduced torque	Phases A and B, A and C or B and C reversed.	Check and correct motor power wiring.
	Sine, Cosine or Rotor leads are reversed in the feedback cable connector.	Check and correct motor feedback wiring.
	Sine, Cosine, Rotor lead sets of resolver feedback are reversed.	Check and correct motor feedback wiring.

Replacing System and Axis Modules

Use these procedures to:

- Determine what you need to replace modules
- Remove an axis module
- Install a replacement axis module
- Remove a system module
- Install a replacement system module



ATTENTION: This drive contains ESD (Electrostatic Discharge) sensitive parts and assemblies. You are required to follow static control precautions when you install, test, service, or repair this assembly. If you do not follow ESD control procedures, components can be damaged. If you are not familiar with static control procedures, refer to Allen-Bradley publication 8000-4.5.2, Guarding Against Electrostatic Damage or any other applicable ESD Protection Handbook.

Before You Begin

Before you replace modules, be sure to have the following:

- A phillips screw driver
- A standard screw driver
- A voltmeter
- A nutdriver
- A wrench

Removing an Axis Module

To remove an axis module:

1. Remove 24V control power and 360/480V AC input power from the system.



ATTENTION: To avoid shock hazard or personal injury, assure that all power has been removed before proceeding. This system may have multiple sources of power. More than one disconnect switch may be required to de-energize the system.

2. Allow five minutes for the DC bus to completely discharge before proceeding.



ATTENTION: This product contains stored energy devices. To avoid hazard of electrical shock, verify that all voltage on the capacitors has been discharged before attempting to service, repair, or remove this unit. You should only attempt the procedures in this chapter if you are qualified to do so and familiar with solid-state control equipment and the safety procedures in publication NFPA 70E.

3. Remove connectors (TB1 and TB2) from the bottom of the axis module.
4. Label and remove the motor leads and ground wiring from the terminal block on the axis module.
5. Disconnect the slide-and-lock mechanism on the module you plan to remove and all modules to the right of it.
6. Remove the bottom fastener on the axis module you plan to remove.
7. Loosen the top fastener on the axis module you plan to remove.
8. Lift the axis module and pull it out.
9. If you are removing the right-most axis module, remove the terminator.

Installing a Replacement Axis Module

To install a replacement axis module:

1. Install the top mounting fastener on the system panel for the axis module. The head of the fastener should be at least 6.35 mm (0.25 in.) from the panel. Refer to *Mounting the 1394* in the *Installing Your 1394* chapter for more information.

2.

If you are mounting:	Do this:
A 1394x-AM03, -AM04, -AM07 -AM50-IH, or -AM75-IH axis module	Go to main step 3.
A 1394x-AM50 or -AM75 axis module with the heat sink through the back of the enclosure	<ol style="list-style-type: none"> 1. Remove the paper backing from the gasket that came with the AM50/75 axis module. 2. Position the gasket so that the small hole side is on top. 3. Slide the gasket over the heat sink and attach it to the back of the axis module. 4. Go to main step 3.

3. Hang the axis module on the next mounting fastener.
4. Engage the alignment tab.
5. Slide the slide-and-lock mechanism on the axis module to the left until it locks into place.
6. Install the lower fastener for all axis modules.
7. If not already attached, attach the terminator to the last axis module slide-and-lock mechanism until it locks in place.
8. Tighten all mounting fasteners.
9. Reconnect TB1, TB2, motor, and ground wires.
10. Apply power to the system.
11. Verify that the system is operating properly.

Note: Because system and axis parameters reside in the system module software, you do not need to perform any tuning or setup at this time.

Removing a System Module

If you are removing a:	Refer to:	Publication number:
9/440 system module	9/Series Integration and Maintenance Manual	8520-6.2
SERCOS system module	1394 SERCOS Multi-Axis Motion Control System User Manual	1394-5.20

To remove a system module:

1. Remove all 360/480V AC input power from the system.



ATTENTION: This product contains stored energy devices. To avoid hazard of electrical shock, verify that all voltage on the capacitors has been discharged before attempting to service, repair, or remove this unit. You should only attempt the procedures in this chapter if you are qualified to do so and familiar with solid-state control equipment and the safety procedures in publication NFPA 70E.

- 2.

If you are removing a:	Do this:
Analog Servo system module with a HIM module mounted in the door	<ol style="list-style-type: none"> 1. Upload the drive parameters from the system module using the Copy Cat feature. Refer to <i>Appendix C</i> for Copy Cat instructions. 2. Open the system module door. 3. Disconnect the SCANport cable. 4. Using a screw driver, disengage the two locking tabs inside the system module door that hold the HIM in place. 5. Remove the HIM module. 6. Go to main step 3.
Analog Servo system module without a HIM module mounted in the door	<ol style="list-style-type: none"> 1. Upload the drive parameters from the system module using the Copy Cat feature. Refer to <i>Appendix C</i> for Copy Cat instructions. 2. Go to main step 3.
GMC Turbo, GMC or system module	<ol style="list-style-type: none"> 1. Verify that you have a copy of your GML program. Refer to your GML programming manuals for upload options. 2. Go to main step 3.
CNC interface system module	Go to main step 3.

3. Remove all 24V control input power from the system.

Note: 1394 input power and shunt connections are located on the lower front of a Series A and B system module. The same connections are located on the bottom of a Series C system module. For complete system interconnect information refer to *Appendix B*.



ATTENTION: To avoid shock hazard or personal injury, assure that all power has been removed before proceeding. This system may have multiple sources of power. More than one disconnect switch may be required to de-energize the system.

4. Allow five minutes for the DC bus to completely discharge before proceeding.
5. Label and remove the 24V control power wiring from the system module.
6. Label and remove the 360/480V AC input power wiring from the system module.
7. Label and remove the ground wire and the external shunt connections (if applicable).
8. Label and remove the feedback and communication connectors from the bottom of system module.
9. Disconnect the slide-and-lock mechanism on the system module.
10. Open the system module door.
11. Label and remove any feedback and/or communication connectors from the control board.
12. Remove the input wiring board.
13. Loosen the top and bottom fasteners that hold the module in place.
14. Lift the module up and pull it out.

Installing a Replacement System Module

To install a replacement system module:

1. Install the top mounting fasteners on the system panel for the system module. The heads of the fasteners should be at least 6.35 mm (0.25 in.) from the panel. Refer to *Mounting Your 1394 System* in the *Installing Your 1394* chapter for more information.
2. Hang the 1394 System Module on the two mounting fasteners on the left side of the panel.
3. Install the lower fasteners for the system module.

4.

If you removed a:	Do this:
Analog Servo system module with a HIM module mounted in the door	<ol style="list-style-type: none"> 1. Remove the HIM or cover plate from the new system module. 2. Install the HIM module you removed from your existing drive into the door of your replacement system module. 3. Open the system module door. 4. Plug the SCANport cable from the drive in the top of the HIM module. 5. Go to main step 6.
Analog Servo system module without a HIM module mounted in the door	Go to main step 5.
GMC, GMC Turbo, or CNC, system module	Go to main step 5.

5. Open the system module door.

6.

If your old system module is:	And your new system module is:	Do this:
Series A and B	Series A and B	Go to <i>Replacing System Modules of the Same Series</i> .
Series A and B	Series C	Go to <i>Replacing System Modules of a Different Series</i> .
Series C	Series C	Go to <i>Replacing System Modules of the Same Series</i> .
Series C	Series A and B	Go to <i>Replacing System Modules of a Different Series</i> .

Important: To avoid damaging the wires, miswiring the input wiring board, and potential damage to the system, only replace the input wiring board when replacing a system module of a different series (refer to the table above).

Note: To determine the series of your module, refer to Figure P.1 in the *Preface*.

Replacing System Modules of the Same Series

1. Remove the input wiring board from the new system module.
2. Re-install the old input wiring board into the new system. Tighten it to the main board chassis using a phillips screw driver and the screws provided.
3. Go to *Completing Connections and Downloading Parameters*.

Replacing System Modules of a Different Series

1. Label and remove the wires from the old input wiring board.
2. Re-insert the wires into the new wiring board.
3. Go to *Completing Connections and Downloading Parameters*.

Completing Connections and Downloading Parameters

1. Connect the slide-and-lock mechanism on the system module to the axis modules.
2. Reconnect feedback and communication connectors to the system module. Refer to *Appendix B* for connection information.
3. Connect the ground wire and if used, the external shunt resistor connections.
4. Connect the 24V control power and 360/480V AC input power to the system module.
5. Connect all shunt wiring (if applicable).
6. Apply 24V control power to the system module.
- 7.

If you are commissioning a:	Do this:
Analog Servo system	<ol style="list-style-type: none"> 1. Download the drive parameters to the system module using the Copy Cat feature. Refer to Appendix C for Copy Cat instructions. 2. Go to main step 8.
GMC Turbo or GMC system module	<ol style="list-style-type: none"> 1. Download your GML program. Refer to your GML programming manuals for more information. 2. Go to main step 8.
CNC Interface system module	Go to main step 8.

8. Apply 360/480V AC input power to the system module.
9. Verify that your system is operating properly.

Checking for a Blown Fuse in the 1394-DCLM

To check the 1394-DCLM for a blown fuse:

1. Remove power from your system including the 1394-DCLM.



ATTENTION: To avoid shock hazard or personal injury, assure that all power has been removed before proceeding. This system may have multiple sources of power. More than one disconnect switch may be required to de-energize the system.



ATTENTION: To avoid hazard of electrical shock, verify that all voltage on the capacitors has been discharged before attempting to service, repair, or remove this unit. This product contains stored energy devices. You should only attempt the procedures in this document if you are qualified to do so and familiar with solid-state control equipment and the safety procedures in publication NFPA 70E.

2. Remove the terminator from the right side of the 1394-DCLM.

Figure 9.3
Removing the Terminator from the 1394-DCLM

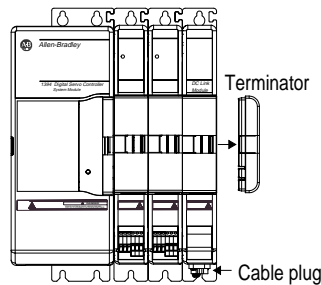

3. Remove either the power plug from the stand-alone 1394-DCLM (shown above) or remove the cable linking two systems together, as shown below.

Figure 9.4
Removing the Cable from the 1394-DCLM

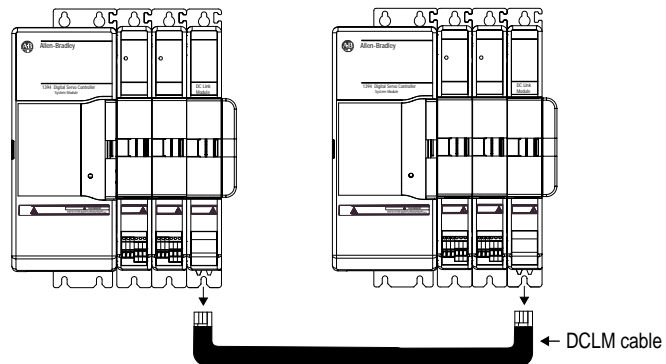

4. Check the circuit resistance of the two DCLM fuses by connecting the probes of an ohm meter as described in the table below. Refer to Figure 9.5 for the connector locations.

Connect the red lead to:	Connect the black lead to:	If the meter reading is:	The 1394-DCLM fuse is:
Top bus (DC+) power connector	Left front socket	Open (high ohms)	Blown. Replace the 1394-DCLM.
		Short (low ohms)	Good.
Bottom bus (DC-) power connector	Right front socket	Open (high ohms)	Blown. Replace the 1394-DCLM.
		Short (low ohms)	Good.

Figure 9.5
Checking for a Blown Fuse

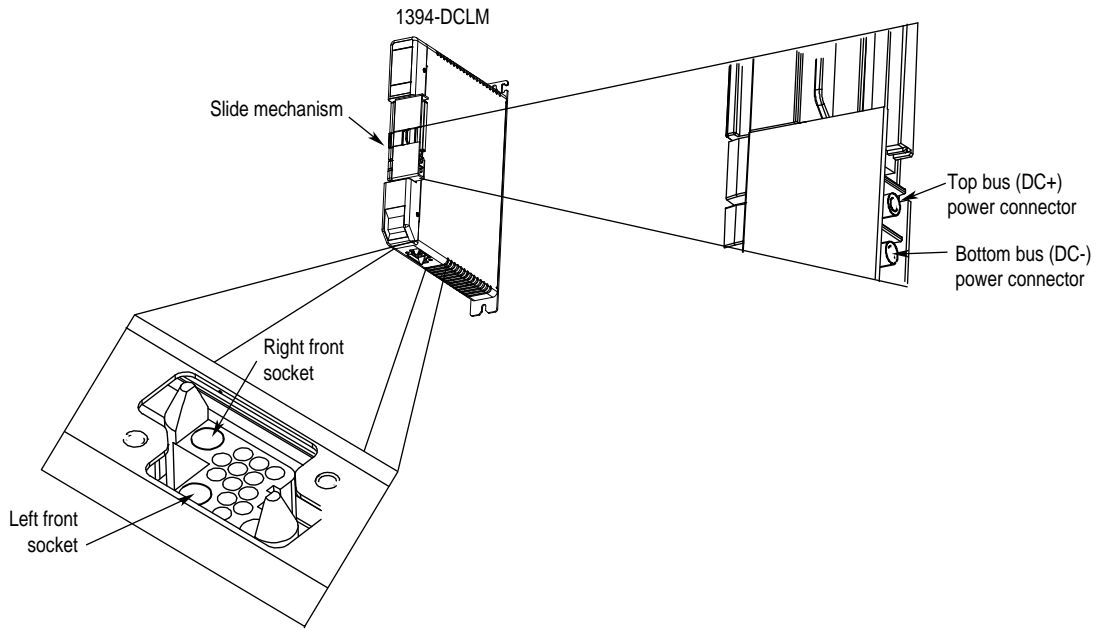

Replacing the 1394 Shunt Module Fuse

To replace the fuse in 1394 shunt modules (Catalog Numbers 1394-SR10A, -SR9A, -SR9AF, -SR36A, and -SR36AF) refer to the specific set of instructions.

Replacing the 1394-SR10A Fuse

1. Remove power from your system including power to the shunt module.



ATTENTION: This system may have multiple sources of power. More than one disconnect switch may be required to de-energize the system. To avoid shock hazard or personal injury, verify that all power has been removed before proceeding.



ATTENTION: This product contains stored energy devices. To avoid hazard of electrical shock, verify that all voltage on the capacitors has been discharged before attempting to service, repair, or remove this unit. You should only attempt the procedures in this document if you are qualified to do so and familiar with solid-state control equipment and the safety procedures in publication NFPA 70E.

2. Locate the fuse holder.

Figure 9.6
Fuse Holder Location

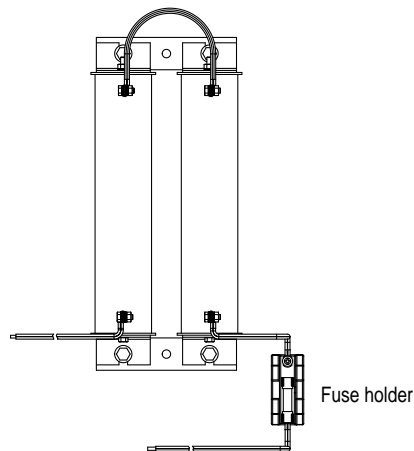

3. Remove the fuse from the fuse holder with the fuse puller tool.
4. Insert the new Bussmann 700V 40A fuse (FWP40A14F) or equivalent into the 1394-SR10A fuse holder.
5. Apply power to your system.

Replacing the 1394-SR9A, -SR9AF, -SR36A, and -SR36AF Fuse

To replace the 1394-SR9A, -SR9AF, -SR36A, and -SR36AF shunt module fuse:

1. Remove power from your system including the shunt module.



ATTENTION: To avoid shock hazard or personal injury, verify that all power has been removed before proceeding. This system may have multiple sources of power. More than one disconnect switch may be required to de-energize the system.



ATTENTION: To avoid hazard of electrical shock, verify that all voltage on the capacitors has been discharged before attempting to service, repair, or remove this unit. This product contains stored energy devices. You should only attempt the procedures in this document if you are qualified to do so and familiar with solid-state control equipment and the safety procedures in publication NFPA 70E.

2. Examine the fuse label for the UL mark.

Figure 9.7

Locating the UL Mark on the Fuse Label

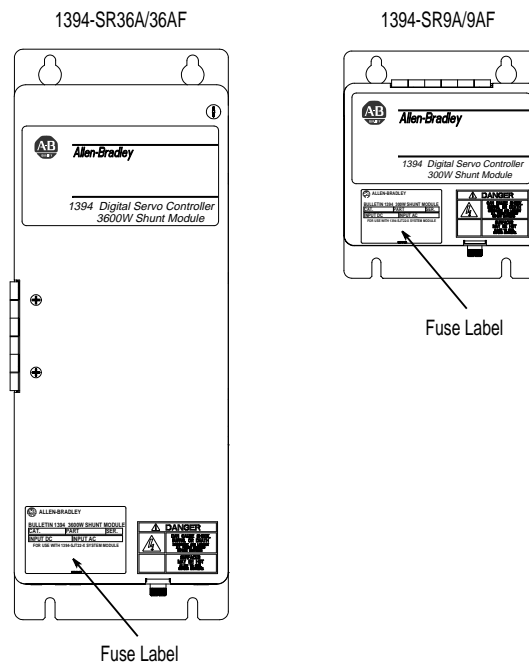

3.

If your 1394-SR9A, -SR9AF, -SR36A, or -SR36AF shunt module:	You need a:
Has the UL mark	Bussmann 600V DC 50A fuse (FWP50A14F) or equivalent.
Does not have the UL mark	Bussmann 600V DC 40/50A fuse (170N2013), FWP50A22F or equivalent.

4. Locate the door panel latch(es).

Figure 9.8
1394 Shunt Modules Door Latches

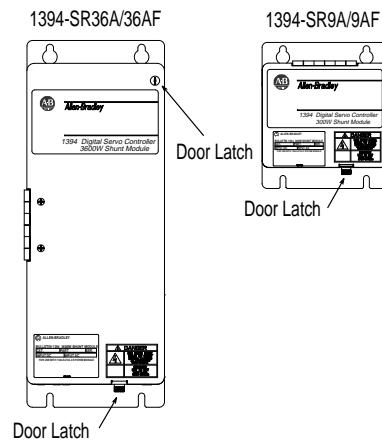

5. Undo the door panel latch(es).

6. Open the door panel.

7. Locate the fuse holder.

Figure 9.9
Locating the Fuse Holder for the 1394 Shunt Modules

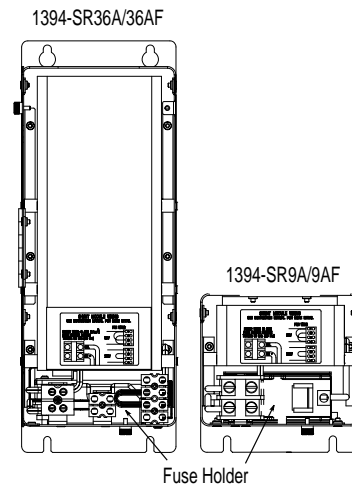

8. Remove the fuse from the fuse holder with the fuse puller tool.

If your 1394-SR9A, -SR9AF, -SR36A, or -SR36AF shunt module:	Replace the fuse with a:
Has the UL mark	Bussmann 600V DC 50A fuse (FWP50A14F) or equivalent.
Does not have the UL mark	Bussmann 600V DC 40/50A fuse (170N2013), FWP50A22F or equivalent.

9. Close the door panel.
10. Secure the door panel.
11. Apply power to your system including the shunt module.

Replacing the AM50 and AM75 Axis Module Fan

The following procedure provides instructions for removal and replacement of the 10 and 15 kW axis module (1394x-AM50 and -AM75) fan using kit number SP-74102-271-01.

Note: This procedure does not apply to the 1394C-AM50-IH or the 1394C-AM75-IH. The fan in these axis modules are not customer replaceable.

Removing the Fan

1. Remove power from your system including the axis module.



ATTENTION: This system may have multiple sources of power. More than one disconnect switch may be required to de-energize the system. To avoid shock hazard or personal injury, assure that all power has been removed before proceeding.



ATTENTION: This product contains stored energy devices. To avoid hazard of electrical shock, verify that all voltage on the capacitors has been discharged before attempting to service, repair, or remove this unit. You should only attempt the procedures in this document if you are qualified to do so and familiar with solid-state control equipment and the safety procedures in publication NFPA 70E.

2. Remove the axis module from the 1394 system.

3. Place the axis module on its side so you can locate the fan housing.

Figure 9.10
Fan Housing on Axis Module

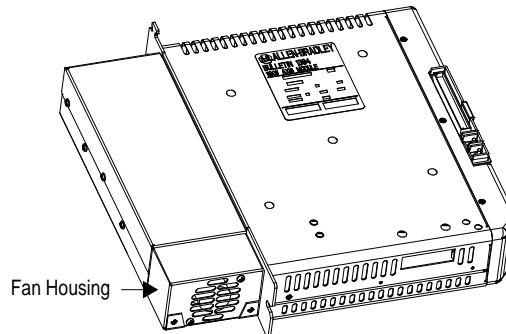

4. Remove the screws that hold the fan housing to the axis module.

Figure 9.11
Fan Housing Screws

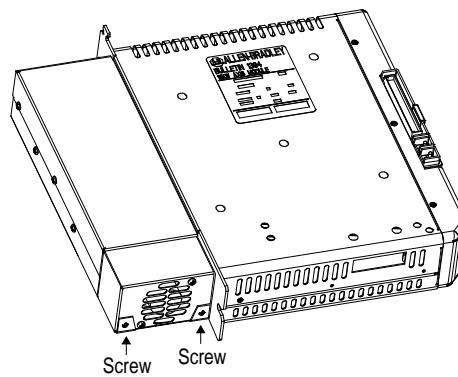

5. Gently slide the fan housing out a short distance until you see the fan plug.

Figure 9.12
Fan Plug

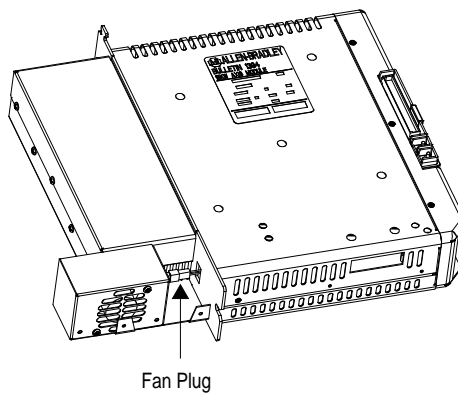

6. Unplug the fan housing from the axis module.
7. Locate the fan gasket that is attached to the fan housing.

Figure 9.13
Locating the Fan Gasket

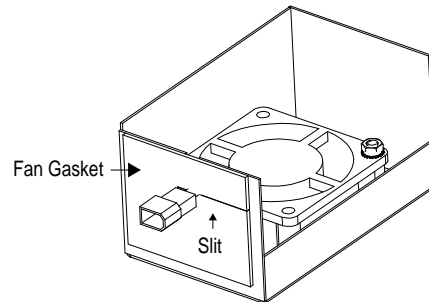

8. Remove the fan gasket from the fan housing. Make sure you slide the fan wires through the slit in the gasket.
9. Remove the screws and nuts that hold the fan to the fan housing.

Figure 9.14
Removing Fan Screws and Nuts

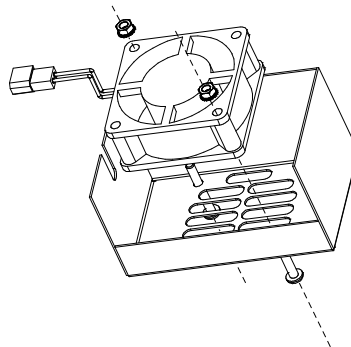

10. Remove the fan from the fan housing.

Installing the New Fan

1. Insert the new fan into the fan housing.

Figure 9.15
Fan Inserted into the Fan Housing

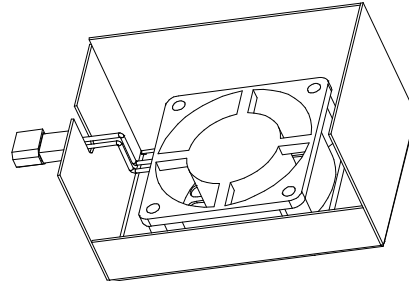

2. Peel the adhesive backing off of the new fan gasket.
3. Attach the new fan gasket to the fan housing in the direction shown in the figure below. Make sure you compress the slit in the gasket to minimize the air gap in the gasket.

Figure 9.16
Attaching the New Fan Gasket

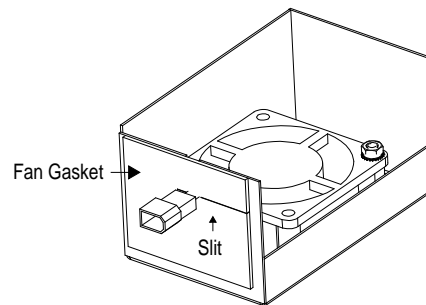

4. Press the gasket firmly to the fan housing to secure the gasket.

- Secure the fan to the fan housing with two M4 screws and nuts using 1.6 N-m (14 lb-in.) of torque.

Figure 9.17
Securing the Fan to the Fan Housing

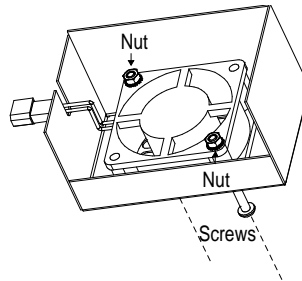

- Align the fan housing to the axis module.
- Plug the fan into the axis module.

Figure 9.18
Fan Plug Attached to the Axis Module

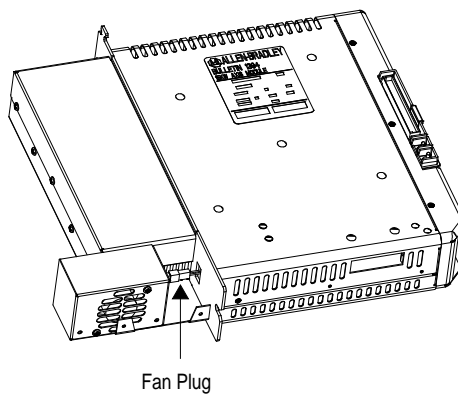

- Slide the fan housing back into place.
- Secure the fan housing with two M3 x 6 mm screws using 0.70 N-m (6 lb-in.) of torque to the axis module.
- Place the axis module back into your 1394 system and apply power.

Specifications

Chapter Objectives

Appendix A contains specifications and dimensions for the 1394 system and dimensions and operating characteristics for the 1326AB/AS series servo motors. This appendix covers:

- System specifications
- Environmental specifications
- Power dissipation
- Communication specifications
- Dimensions
- Servo motor performance data

System Specifications

General 1394 specifications are provided below. Specifications are for reference only and are subject to change without notice.

Certification

The 1394 is certified for the following when the product or package is marked:

- UL listed (File E59272)
- CUL listed
- CE marked for all applicable directives

System Modules

The table below lists the specifications for system modules.

The:	For the 1394x-SJT05 ^{1,2} is:	For the 1394x-SJT10 ^{1,2} is:	For the 1394x-SJT22 ¹ is:
Rated AC input voltage	324-528V AC, 50/60 Hz Three phase	324-528V AC, 50/60 Hz Three phase	324-528V AC, 50/60 Hz Three phase
AC input current	6.5A	13.0A	28.6A
Peak inrush current ^{4,5} (Series A and B) ³	975A	1300A	697A < 1μs
Peak inrush current ⁴ (Series C)	697A < 1μs	697A < 1μs	697A < 1μs
Line loss ride through	20 ms	20 ms	20 ms
Nominal bus output voltage	530/680V DC	530/680V DC	530/680V DC
Continuous power output	4/5 kW	8/10 kW	17/22 kW
Peak power output	28 kW	28 kW	136 kW
Efficiency	99%	99%	98%
Number of Electronic Cam Profile Points	13,000 Master/slave	13,000 Master/slave	13,000 Master/slave
Weight (Series A and B)	11 kg (24.25 lb)	11 kg (24.25 lb)	12.7 kg (28.0 lb)
Weight (Series C)	10.68 kg (23.5 lb)	10.68 kg (23.5 lb)	12.9 kg (28.5 lb)
Continuous current output	7.36A	14.73A	33.8A
Peak current output	15.0A	29.46A	200A
Capacitance (Series A and B)	220 μF	330 μF	660 μF
Capacitance (Series C)	220 μF	345 μF	660 μF
Inductance	1000 μH	750 μH	500 μH
Internal shunt resistor	200W continuous, 40,000W peak (two second maximum on time)		No internal Shunt Resistor

¹ The Standard GMC and GMC Turbo system modules are identical except that the GMCTurbo (1394x-SJTxx-T) offers a SLC backplane interface and 64K of memory with a 32-bit processor while the Standard GMC (1394x-SJTxx-C) offers 32K of program memory with a 16-bit processor without the SLC interface.

² The Standard GMC (1394C-SJTxx-L) is functionally the same as the (1394x-SJTxx-C) except it supports one axis and provides two auxiliary encoder inputs.

³ To determine the series of your module, refer to Figure P.1 in the *Preface*.

⁴ 5 and 10 kW (Series C) system modules and all 22 kW system modules are limited to four contactor cycles per minute. 5 and 10 kW (Series A and B) system modules are limited to an average of four contactor cycles per hour.

⁵ Peak inrush current for
5 and 10 kW systems
(Series A and B)

$$= \frac{(\text{line voltage} \times 1.1 \times \sqrt{2})}{\sqrt{\left(\frac{L_{\text{system}}}{C_{\text{system}} + C_{\text{axes}}}\right)}}$$

Where: L = Inductance
C = Capacitance

Axis Modules

The table below lists the specifications for the axis modules.

The:	For the 1394x-AM03 is:	For the 1394x-AM04 is:	For the 1394x-AM07 is:	For the 1394x-AM50 and 1394C-AM50-IH is:	For the 1394x-AM75 and 1394C-AM75-IH is:
Speed Regulation ¹	0 to 0.05% of base speed with 100% torque disturbance	0 to 0.05% of base speed with 100% torque disturbance	0 to 0.05% of base speed with 100% torque disturbance	0 to 0.05% of base speed with 100% torque disturbance	0 to 0.05% of base speed with 100% torque disturbance
Static Gain (rms A/mV) ¹	1.28	2.6	4.9	22.8	22.8
Peak Current Limit Adjust	200%	200%	200%	143%	143%
Modulation Frequency	5 kHz ±10%	5 kHz ±10%	5 kHz ±10%	5 kHz ±10%	5 kHz ±10%
Drift	0.03 rpm/degree C	0.03 rpm/degree C	0.03 rpm/degree C	0.03 rpm/degree C	0.03 rpm/degree C
Nominal Input Voltage	530/680V DC	530/680V DC	530/680V DC	530/680V DC	530/680V DC
Continuous Current (rms)	3.0A	4.5A	7.5A	23.3A	35.0A
Peak Current (rms - 1 second)	6.0A	9.0A	15.0A	33.2A	50.0A
Continuous Power Out 360/460V nominal	1.6/2 kW	2.4/3 kW	4/5 kW	11.34/15.6 kW	17.8/23.8 kW
Efficiency	98%	98%	98%	98%	98%
Weight	5 kg (11.02 lb)	5 kg (11.02 lb)	5 kg (11.02 lb)	7 kg (15.44 lb) (-AM50) 6.73 kg (14.8 lb) (-AM50-IH)	7 kg (15.44 lb) (-AM75) 6.73 kg (14.8 lb) (-AM75-IH)
Capacitance	110 μF	110 μF	220 μF	465 μF	660 μF

¹ When used with the controller in the 1394x-SJTxx system module.

Contact Ratings

The table below lists the contact ratings of the drive relay outputs.

The contact rating for the:	Is:
Drive OK (DROK)	115V AC/24V DC, 1A inductive
Contact Enable Relay	115V AC/24V DC, 1A inductive
Thermal switch	115V AC/24V DC, 1A inductive

DC Link Module

The table below lists the specifications for the DC Link Module.

The:	For the 1394-DCLM is:
Firmware version	5.0 or higher with 1394x-SJTxx-A systems 3.7 or higher with 1394x-SJTxx-C-xx and -T-xx systems 3.9 or higher with 1394C-SJTxx-L-xx systems
Software	GML Commander, version 4.02 or higher
Input voltage	530/680V DC, single phase
Current	Continuous (rms) 32A, Peak (rms - 1 second) 200A
Capacitance	990 μ F
Energy storage	7.36 joules based on a nominal 50V bus delta
Cables available (part numbers)	1394-CPDC-0015 and 1394-CPDC-0030
Cable lengths available	1.5 m (4.92 ft) or 3 m (9.84 ft)
Operating temperature	0° to 50° C (32° to 122° F)
Relative humidity	5-95%, non-condensing
Weight	4.8 kg (10.5 lbs)

Drive Interface Module

The table below lists the specifications for the Drive Interface Module.

The:	For the 1394-DIM is:
Firmware version	3.7 or higher with 1394x-SJTxx-C-xx and -T-xx systems 3.9 or higher with 1394C-SJTxx-L-xx systems
Software	GML Commander, version 4.01 or higher
Input voltage	24V, 50 kHz provided by the 1394x-SJT-xx system module
Analog output information (Px-1,2)	
Voltage	0 to \pm 10V analog
Signal isolation	1500V rms
Resolution	12 bits, 4.88 mV
Impedance	220 ohms
Offset	\pm 80 mV maximum, compensated to 0 through software setup
Drive OK	15V DC @ 5 mA supplied by the DIM
Drive enable output	30V DC @ 1 A
Operating temperature	0° to 50° C (32° to 122° F)
Relative humidity	5-95%
Weight	3 kg (6.6 lb)

Filters

The table below shows the requirements for filters that you can use.

The:	For the SP-74102-006-01 is:	For the SP-74102-006-02 is:	For the SP-74102-006-03 is:
Frequency	50/60 Hz	50/60 Hz	50/60 Hz
Voltage	460V AC	460V AC	460V AC
Current	23A @ 50° C (73.4° F)	30A @ 50° C (86° F)	75A @ 50° C (122° F)
Operating Temperature	-25° to 85° C (-13° to 185° F)	-25° to 85° C (-13° to 185° F)	-25° to 85° C (-13° to 185° F)
Vibration	10-200 Hz @ 1.8 g	10-200 Hz @ 1.8 g	10-200 Hz @ 1.8 g
Humidity	90%	90%	90%
Weight	1.6 kg (4.16 lb)	2.7 kg (7.02 lb)	5.2 kg (13.52 lb)
Power Loss	20W	38W	57W
Roxburgh Catalog No.	MIF323-GS	MIF330-GS	MIF375-GS

User-Supplied Contactor (M1)

The table below shows the requirements for the contactor that you must supply.

The contactor:		For the 1394-SJT05 and -SJT10 (Series A and B) is:	For the 1394C-SJT05 and -SJT10 (Series C) is:	For the 1394x-SJT22 is:
Rating		600V AC, 43A ¹	600V AC, 23A	600V AC, 37A
Recommended types:	AC Coil Operation	Allen-Bradley 100-C43x10 ^{2,3}	Allen-Bradley 100-C23x10 ^{2,3}	Allen-Bradley 100-C37x10 ^{2,3}
	DC Coil Operation	Allen-Bradley 100-C43Zx10 ²	Allen-Bradley 100-C23Zx10 ²	Allen-Bradley 100-C37Zx10 ²

¹ Consider using a 60A contactor when the total capacitance of the axis modules is greater than 880 μ F.

² x indicates coil voltage.

³ A surge suppressor is required.

User-Supplied Line Input Fusing

The table below shows the requirements for the input fusing that you must supply.

The Recommended type of fuse for:		Is:	Rating
1394-SJT05 systems	Series A and B	Bussmann FRS-R-20A or equivalent	600V AC, 20A
1394C-SJT05 systems	Series C	Bussmann KTK-R-20 or equivalent	600V AC, 20A
		Bussmann LPJ-SP 20 or equivalent	600V AC, 20A
1394-SJT10 systems	Series A and B	Bussmann FRS-R-30A or equivalent	600V AC, 30A
1394C-SJT10 systems	Series C	Bussmann KTK-R-30 or equivalent	600V AC, 30A
		Bussmann LPJ-SP 30 or equivalent	600V AC, 30A
1394x-SJT22 systems		Bussmann FRS-R-35 or equivalent	600V AC, 35A
		Bussmann LPS-RK-SP 40 or equivalent	600V AC, 40A
		Bussmann LPJ-SP 45 or equivalent	600V AC, 45A

User-Supplied 24V Logic Input Power

The table below shows the requirements for the 24V logic input power that you must supply.

24V logic input voltage	Frequency	Current ¹		Recommended Fuse
		If you have:	The current draw for user-supplied power supply must not exceed:	
19-28V AC RMS, single phase or 18.75-31.25V DC	50/60 Hz	1 axis	3.5A	Bussmann MDA-15 or equivalent
2 axis		4.4A		
3 axis		5.2A		
4 axis		6.0A		

¹ The power supply should be rated for 15A or greater inrush current upon power up.

Input Transformer for 24V Control Power

You can use any general purpose transformer with the following ratings.

The requirements for:	For a 480V system is:	For a 360V system is:
Input volt-amperes	200 to 259 VA	200 to 259 VA
Input voltage	480V RMS	360V RMS
Output voltage	24V RMS	24V RMS
Load regulation	2 to 5%	2 to 5%

If the input volt-amperes is more than 350 VA, adjust the load regulation to make the transformer leakage the same as or greater than the 250 VA transformer with 2% regulation.

User-Supplied 5V Auxiliary Encoder Power Supply

The table below shows the requirements for the 5V encoder that you can supply. If you use an encoder that requires more than 5V, you still need a 5V power supply for the 1394 encoder board electronics at a rating of 0.325A (applies to 1394x-SJTxx-C, -L, and -T systems only).

The:	For 5V logic input power must be:
Rating	5V DC +/- 5%
Current	0.325A plus the requirement of each encoder used. For example, if you use one encoder with a 0.2A requirement, the supply required is 0.525A (0.325A + 0.2A = 0.525A)

Circuit Breakers

While circuit breakers offer some convenience, there are limitations for their use. Circuit breakers do not handle high current inrush as well as fuses. The 1394 system needs to be protected by a device having a short circuit interrupt current rating of the service capacity provided or a maximum of 100,000A.

If an upstream circuit protection device is rated for the overload current and short circuit rating, a supplementary circuit protection device (such as the 1492) can be used as the only 1394 branch circuit protection device. The upstream fully rated device let-through must be less than or equal to the 10 kA interrupt rating of the 1492.

The wiring interconnection in Figure A.1 and Figure A.2 provide examples of the needed protection and follows UL and NEC codes. Full compliance is dependent on final wiring design and installation.

Figure A.1
Circuit Protection under NEC 1999 110-10 (preferred fully rated devices)

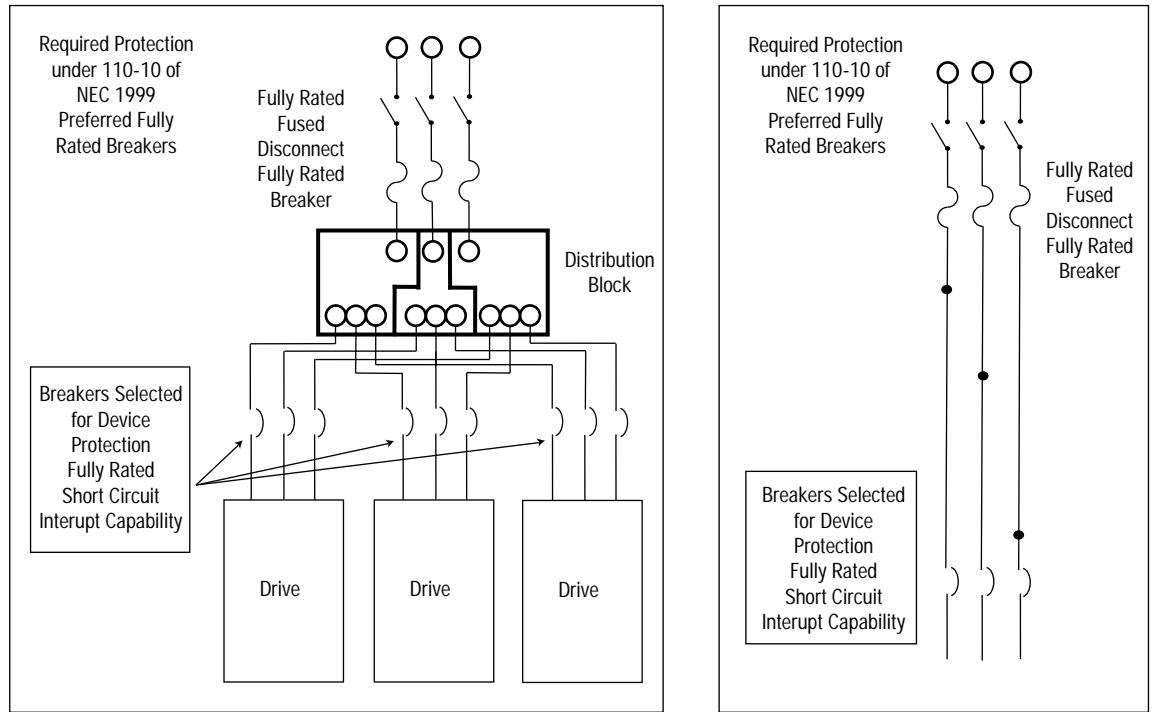
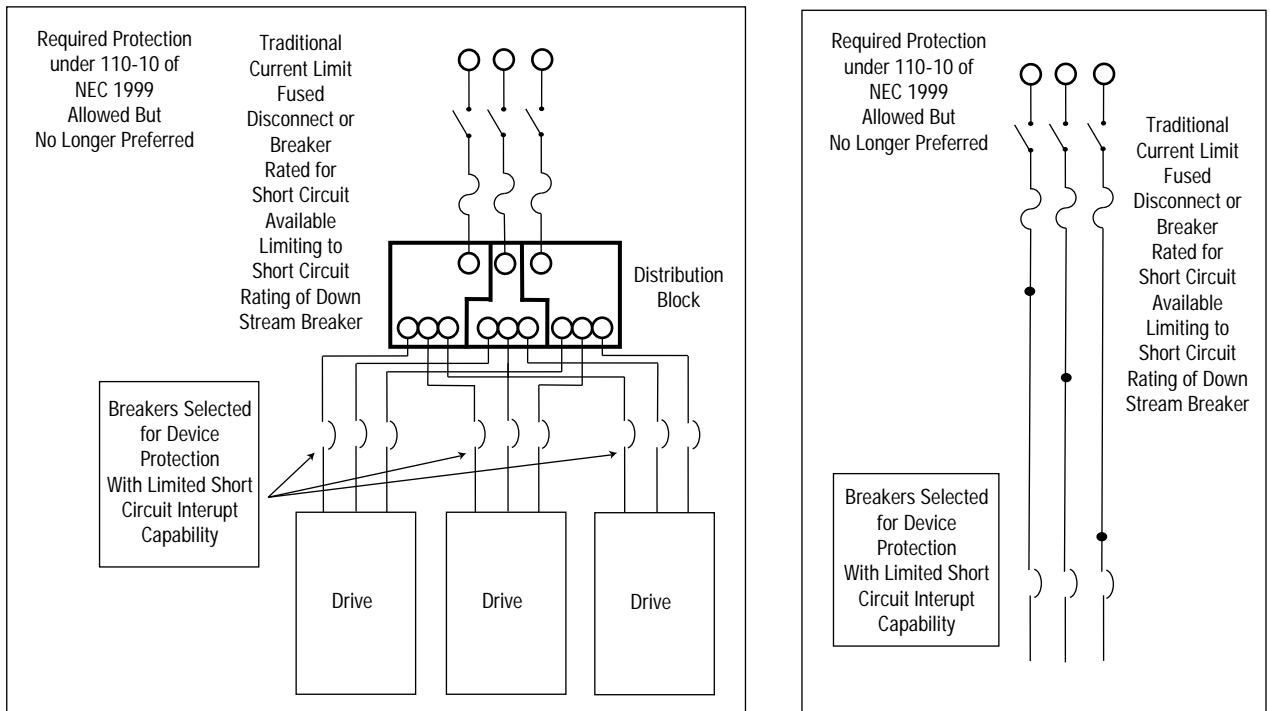

Figure A.2
Circuit Protection under NEC 1999 110-10 (allowed but no longer preferred)



To avoid nuisance tripping, refer to the following table and select the appropriate combination of system module, secondary circuit protection device, and axis modules.

Use System Module:	With Secondary Circuit Protection Device:	And Axis Module Combination:
1394x-SJT05-x	1492-CB3-H300	Any combination of AM03 and AM04 up to 4 axis modules. Any combination of AM03, AM04, and AM07 where no more than two AM07s are being used. Use of other combinations of axis modules with this system module may result in nuisance tripping on power up due to a higher inrush current.
	A 1492 device is not recommended for this option.	Other combinations of AM07, AM50, and AM75s. Some local electrical codes require that the circuit breaker rating not exceed 400% of the full load device current. The inrush current draw of the 1394 in some combinations exceeds the 30A breaker and will result in nuisance tripping.
1394x-SJT10-x	1492-CB3-H500	All
1394x-SJT22-x	1492-CB3-H600	All

External Shunt Resistor Kit for 5 and 10 kW Systems

The table below shows the ratings for the external (optional) shunt resistor.

Catalog Number	Ratings	Shipping Weight	Resistance
1394-SR10A	1400W continuous, 40,000W peak (two second maximum on time)	4.99 kg (11 lb)	16 Ohms

Important: Use fuse replacement kit (1394-SR10A-FUSE-A) when replacing the 1394-SR10A shunt fuse. Refer to the *Miscellaneous Accessories* section in *Appendix D* for more information.

1394 Shunt Module for the 22 kW System

The table below shows the ratings for the 1394 shunt module for the 22 kW system module.

Catalog Number	Series Letter	Ratings	Shipping Weight	Resistance	Agency Certifications
1394-SR9A	B	300W continuous, 160,000 W peak, module (no fan)	3.63 kg (8 lb)	4 Ohms	For all applicable directives: <ul style="list-style-type: none"> • UL Listed (file #E59272) • CUL Listed • CE marked
1394-SR9AF	B	900W continuous, 160,000 W peak, module (no fan)	3.63 kg (8 lb)		
1394-SR36A	B	1800W Continuous, 160,000 W peak, module (no fan)	8.6 kg (19.0 lb)		
1394-SR36AF	B	3600W continuous, 160,000 W peak, fan-cooled module	9.0 kg (20.0 lb)		

Refer to the following table for fuse replacement information.

If your 1394-SR9A, -SR9AF, -SR36A, and -SR36AF shunt module:	You need a:
Has the UL mark	Bussmann 600V DC 50A fuse (FWP50A14F) or equivalent.
Does not have the UL mark	Bussmann 600V DC 40A fuse (170N2013) or equivalent.

Environmental Specifications

Mount the 1394 in an enclosure that is clean and dry [IP55 protection rating minimum (IEC publication 529)]. For enclosures ventilated with ambient air, be sure to have appropriate filtering to protect against contamination. Keep the ambient air temperature between 0° and 50° C (32° and 122° F) and the humidity between 5% and 95%, non-condensing.

The 1394 can operate at elevations to 1000 meters (3300 ft) without derating, however, the continuous current rating must be derated by 3% for each additional 300 m (1000 ft) up to 3000 m (10,000 ft). Consult with your local Allen-Bradley Sales Representative prior to operating at over 3000 m (10,000 ft).

Refer to the table below for 1394 shock and vibration specifications.

Mode	Maximum Shock	Maximum Vibration
Operating	15g	1g
Non-operating	30g	2.5g

Power Dissipation

The power dissipation characteristics of the 1394 system and axis modules are provided below (use for 480V or 360V input).

Important: Use the power dissipation figures shown below to calculate cumulative system heat dissipation to ensure that the ambient temperature inside the enclosure does not exceed 50° C (122° F). To calculate total power dissipation, add the dissipation of the system module to the dissipation of the axis module(s).

System Modules

The power dissipation (in watts) of the system module types is shown below.

% of Rated Power Output	Power Dissipation (in watts)		
	1394x-SJT05-x	1394x-SJT10-x	1394x-SJT22-x
20	66	70	100
40	70	77	150
60	73	84	200
80	77	81	250
100	80	98	300

Axis Modules

The power dissipation (in watts) of the axis modules is shown below:

% of Rated Power Output	Power Dissipation (in watts)								
	Total					Inside Cabinet		Outside Cabinet	
	AM03	AM04	AM07	AM50 ¹ and AM50-IH ²	AM75 ¹ and AM75-IH ²	AM50 ¹	AM75 ¹	AM50 ¹	AM75 ¹
20	24	27	33	56	85	18	18	38	67
40	30	36	48	95	145	18	18	77	127
60	36	45	63	139	212	18	18	138	194
80	42	54	78	183	279	18	18	165	261
100	48	63	93	227	346	18	18	209	324

¹ The AM50/75 are designed to mount with the rear heat sink extended outside the customer-supplied enclosure. If the modules are mounted entirely inside the customer supplied enclosure, the full power dissipation is inside the cabinet.

² The AM50/75-IH are designed to mount entirely inside the customer-supplied enclosure.

DC Link Module

The power dissipation for the 1394-DCLM is shown below.

The:	For the 1394-DCLM is:
Power dissipation	4.225 W maximum

Drive Interface Module

The power dissipation for the 1394-DIM is shown below.

The:	For the 1394-DIM is:
Power dissipation	30 W maximum

Internal Shunt Resistor for the 5 and 10 kW System (standard)

When the shunt resistor inside 1394x-SJT05 and 1394x-SJT10 system module is active, some additional power will be dissipated at the system module. Its maximum dissipation is 200W. Most applications will use less than 10% of this capacity.

The:	Is:
Rating of the internal shunt resistor	200W continuous, 40,000W peak (two second maximum on time)
Resistance of the internal shunt resistor	16 ohms

Communication Specifications

The communication specifications are listed in the tables starting below.

Encoder Input Specifications

The table below lists the encoder input specifications for the system module (1394x-SJTxx-C-xx, -L-xx, and -T-xx systems).

The:	Is:
Number of encoder inputs	4 (axis 0, 1, 2, and 3) for 1394x-SJTxx-C-xx and -T-xx systems 2 (axis 0 and 1) for 1394C-SJTxx-L-xx systems
Type of encoder input	Incremental AB quadrature; optically isolated, differential with marker channel
Encoder interface IC	AM26LS32 or equivalent
Compatible encoder types	Differential, TTI-level (5V DC) line driver outputs, with or without marker
Decode modes	4 times quadrature, step/direction, count up/count down
Maximum encoder frequency	4,000,000 counts per second (4 MHz). This is equivalent to a channel frequency of 1 MHz in 4x quadrature decode mode.
Input impedance	7 kohms minimum (each input)
Encoder power	5V DC @ 1A, user supplied

Dedicated Discrete I/O Specifications

The table below lists the dedicated discrete I/O specifications for the system module (1394x-SJTxx-C-xx, -L-xx, and -T-xx systems).

The:	Is:
Number of dedicated discrete inputs	16 (4 each for axis 0, 1, 2, and 3)
Dedicated discrete input functions	Home limit switch, positive overtravel limit switch, negative overtravel limit switch, position registration, and thermal fault.
Input type	Optically isolated
Operating voltage	24V DC, 28V DC maximum or 5V DC nominal; 10V DC maximum for position registration inputs
Input On current	12 mA per input (nominal); 2.5 mA for position registration inputs
Input impedance	2 kohms (resistive) per input; 8.8 kohms (resistive) for 24 V position registration inputs.
Input response time	5 ms maximum; 1 μ s maximum for position registration inputs

Serial I/O Specifications

The table below lists the dedicated serial I/O specifications for the system module (1394x-SJTxx-C-xx, -L-xx, and -T-xx systems).

The:	Is:
Number of serial channels	2 (serial port A and serial port B)
Channel type	Optically isolated RS-232 or RS-422; each channel individually configured via internal switch
Information code	ASCII
Baud rate	User-selectable up to 128 kbaud (rs-422); 115.2 kbaud (RS-232)
Number of start bits	One
Number of stop bits	One
Word length	8 bits (7 data bits plus 1 parity bit)
Parity	Space parity transmitted; receive parity ignored (may be mark, space, even, or odd)
Duplex	Full or half (user-selectable)
Data synchronization	XON (control-q)/XOFF (control-s)
Front panel connectors	IBM-PC/AT compatible 9-pin D-type female
RS-422 termination	User-selectable 220 ohm resistor via internal switch

DH-485 Specifications

The table below lists the DH-485 specifications for the system module (1394x-SJTxx-C-xx, -L-xx, and -T-xx systems).

The:	Is:
Number of DH-485 channels	One; replaces serial port B when used
Channel type	Optically isolated half-duplex RS-485
Baud rate	9,600 or 19.2 kbaud (user-selectable)
Front panel connectors	Two RJ-45 jacks (+24 V is not provided)
RS-485	User-selectable 220 ohms resistor via internal switch
Node address	User-selectable between 0 and 31 inclusive
Node type	Token-passing master
Accessible data type	<ul style="list-style-type: none"> • One binary file (B3) for up to 16,384 bits • One integer file (N7) for up to 1,024 16-bit values • One floating point file (F8) for up to 512 32-bit values • One ASCII string file (A) for up to 2,048 characters • Nine user-configured files; each can be individually configured as any of the above types or as a BCD file for floating point simulation

Flex I/O Specifications

The table below lists the Flex I/O specifications for the system module (1394x-SJTxx-C-xx, -L-xx, and -T-xx systems).

The:	Is:
Maximum number of Flex I/O modules	8
Compatible modules	<ul style="list-style-type: none"> • 1794-IB16; 16 24V DC discrete inputs • 1794-IA8; 8 115V AC discrete inputs • 1794-IE8; 8 current/voltage analog inputs • 1794-OB16; 16 24V DC discrete outputs • 1794-OA8; 8 115V AC discrete outputs • 1794-OE4; 4 current/voltage analog outputs • 1794-IE4XOE2; 4 current/voltage analog inputs and 2 current/voltage analog outputs • 1794-IB10XOB6; discrete combination module • 1794-OW8 relay output module • 1794-IF4I isolated analog input module • 1794-OB16P discrete output (protected)
Interface	Direct; no 1794-ASB or other adapter required

GMC System Specifications

The table below lists the specifications for the GMC system module (1394x-SJTxx-C-xx, -L-xx, and -T-xx systems).

The:	Is:
Servo loop sample and update rate	250 Hz to 2 kHz for 4 axes
Maximum feedback frequency	4 MHz (4,000,000 feedback counts per second)
Absolute position range	± 1,000,000,000 feedback counts for linear axes; infinite number for rotary axes
Absolute position resolution	15 position unit digits or 32 feedback count bits, whichever is less
Speed range	0.00001 feedback counts per servo update to 4,000,000 feedback counts per second
Speed resolution	15 position unit digits or 15 feedback count bits, whichever is less
Acceleration/deceleration range	0.00001 feedback counts per servo update to 4,000,000 feedback counts per second
Acceleration/deceleration resolution	15 position unit digits or 15 feedback count bits, whichever is less
Electronic gearing gear ratio range	0.00001:1 to 9.99999:1 (slave counts:master counts)
Electronic gearing gear ratio resolution	8 position unit digits or 32 feedback count bits
Servo gain resolution	32-bit floating point
Servo output limit range	0 to 100%
Servo gain units	P = proportional gain (counts per millisecond/error count) I = integral gain (counts per millisecond/error count) V = velocity gain (millivolts/counts per millisecond) F = feedforward gain (counts per millisecond/ counts per millisecond)

Remote I/O Adapter Specifications

The table below lists the remote I/O adapter specifications for the system module (1394x-SJTxx-C-xx, -L-xx, and -T-xx systems).

The:	Is:			
Baud rate	57.6 k, 115.2 k, or 230.4 k (user-selectable)			
Rack address	User-selectable between 0 and 31 decimal			
Rack width	User-selectable in quarter-rack increments (1/4, 1/2, 3/4, or full)			
Transfer type	I/O Group			
Block	0 2 4 6	0 2 4	0 2	0
Discrete	1 3 5 7	1 3 5	1 3	1
Discrete		2 4 6	2 4	2
Discrete		3 5 7	3 5	3
Discrete			4 6	4
Discrete			5 7	5
Discrete				6
Discrete				7
Starting I/O group	0 2 4 6	0 2 4	0 2	0
Rack width	1/4	1/2	3/4	full
Number of discrete I/O bits	<ul style="list-style-type: none"> • 12 dedicated inputs • 12 dedicated outputs • 1/4 rack width with 4 inputs and 4 outputs • 1/2 rack width with 36 inputs and 36 outputs • 3/4 rack width with 68 inputs and 68 outputs • Full rack width with 100 inputs and 100 outputs 			
Maximum block transfer length	64 words (128 bytes)			
Block transfer data types	<ul style="list-style-type: none"> • User variable values • Axis data parameter value • Axis data bit state • Master cam position point values • Master cam time point values • Slave cam position point values • Axis or system variable value 			
Block transfer data formats	<ul style="list-style-type: none"> • 32-bit (double-word) 2s compliment integer • 16-bit (single-word) 2s compliment integer • 32-bit (8-digit) signed BCD • 32-bit IEEE floating point • Word-swapped 32-bit (double-word) 2s compliment integer • Word-swapped 32-bit (8-digit) signed BCD • Word-swapped 32-bit IEEE floating-point 			

AxisLink Specifications

The table below lists the AxisLink specifications for the system module (1394x-SJTxx-C-xx, -L-xx, and -T-xx systems).

The:	Is:	
Baud rate	Standard and extended node configuration	One megabit per second
	Extended length configuration	500 kbits per second
Cable type	Standard and extended node configuration	Allen-Bradley 1770-CD RIO cable (Belden 9463 or equivalent)
	Extended length configuration	Belden 9182, Carol C8014, or equivalent
Cable length	Standard and extended node configuration	25 m (82 ft) maximum. 1 m (3 ft) minimum between controllers.
	Extended length configuration	125 m (410 ft) maximum. 1 m (3 ft) minimum between controllers.
Number of motion controllers	Standard and extended length configurations	8 maximum for a total of 32 possible axes
	Extended node configuration	16 maximum for a total of 64 possible axes
Addressing	Standard and extended length configurations	User-selectable address via rotary selector switch on front panel
	Extended node configuration	User-selectable address via GML
Number of virtual master axis	Standard configuration	4 maximum; 1 per motion controller. Any axis on any motion controller can be a virtual master axis to any other motion controller. Each motion controller can define a total of 2 separate axes on any other motion controllers as virtual master axes, but only one can be active any time. A total of 4 different axes can be active as virtual master axes at any time.
	Extended length and extended node configurations	2 maximum; 1 per motion controller. Any axis on any motion controller can be a virtual master axis to any other motion controller. Each motion controller can define a total of 2 separate axes on any other motion controllers as virtual master axes, but only one can be active any time. A total of two different axes can be active as virtual master axes at any time.
Type of virtual master axes	All configurations	Command and actual. Each virtual master axis may be defined to report its command or actual position.
Slave axes	Standard and extended length configuration	31 maximum total per virtual master axis (3 local + 4 x 7 other motion controllers = 31).
	Extended node configuration	63 maximum total per virtual master axis (3 local + 4 x 15 other motion controllers = 63).
Number of discrete I/O	All configurations	112 inputs maximum and 16 user-defined outputs per motion controller. Any motion controller can read 16 discrete outputs of any other motion controller, giving a maximum of $7 \times 16 = 112$ discrete inputs per motion controller. For extended node configuration, discrete I/O can still only be obtained from a maximum of 7 other controllers (112 inputs maximum), not from all 15 other controllers available in a 16 node maximum extended node configuration.
Discrete I/O response	All configurations	≤ 1 millisecond

Dimensions

Within this section, you will find dimensions for:

- The 1394 system module
- Axis modules (including 1394-DIM and 1394-DCLM)
- Filters
- External shunt modules
- Motors

1394 System Module Dimensions

Figure A.3

1394x-SJT05, 1394x-SJT10 and 1394x-SJT22 System Module

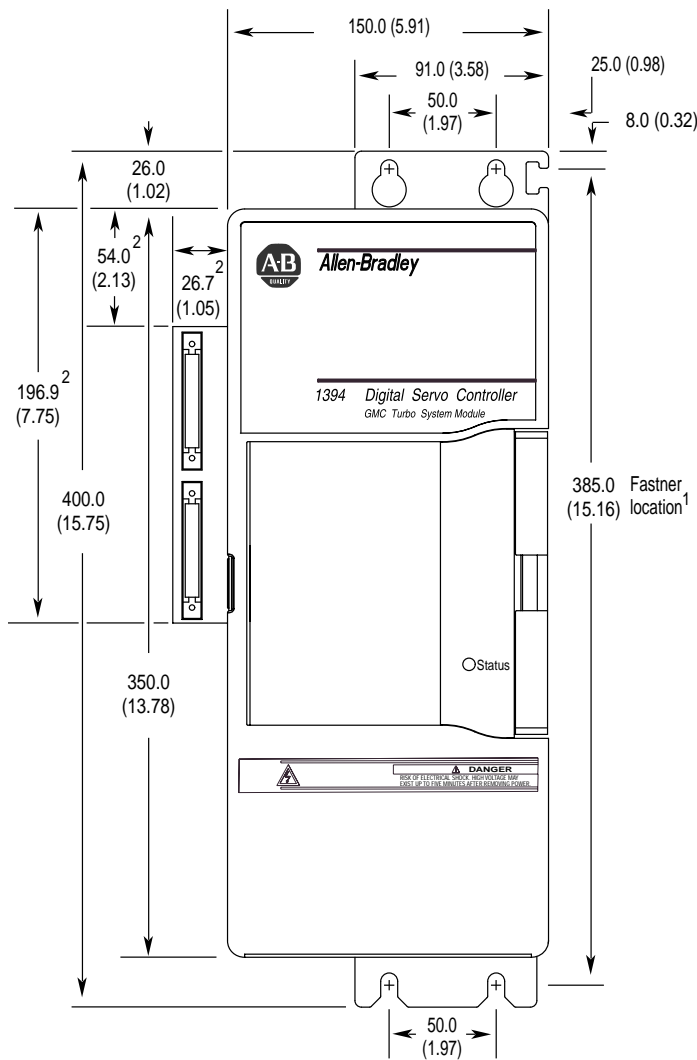

Dimensions are in millimeters and (inches)
Depth = 280 (11.02)

Mounting Hole Detail

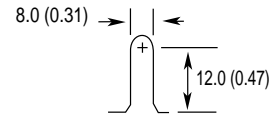
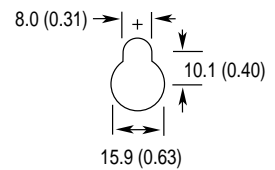

All Slots Accept M6 or 1/4-20 Mtg. Screws

¹ Dimension shown is for mounting hardware location and does not reflect the location of the lower slot radius.

² Dimensions apply to 1394x-SJTxx-T (Turbo) system module only.



ATTENTION: If you are mounting a 1394x-SJT-T system module, you will need an additional 101.6 mm (4 in.) of clearance to the left of the system module to allow for connecting the SLC interface cable (1746-C7 or -C9).