

# HIMatrix

## Safety-Related Controller

### F1 DI 16 01 Manual



HIMA Paul Hildebrandt GmbH + Co KG  
Industrial Automation

All HIMA products mentioned in this manual are protected by the HIMA trade-mark. Unless noted otherwise, this also applies to other manufacturers and their respective products referred to herein.

HIMax<sup>®</sup>, HIMatrix<sup>®</sup>, SILworX<sup>®</sup>, XMR<sup>®</sup> and FlexSILon<sup>®</sup> are registered trademarks of HIMA Paul Hildebrandt GmbH + Co KG.

All of the instructions and technical specifications in this manual have been written with great care and effective quality assurance measures have been implemented to ensure their validity. For questions, please contact HIMA directly. HIMA appreciates any suggestion on which information should be included in the manual.

Equipment subject to change without notice. HIMA also reserves the right to modify the written material without prior notice.

For further information, refer to the HIMA DVD and our website at <http://www.hima.de> and <http://www.hima.com>.

© Copyright 2013, HIMA Paul Hildebrandt GmbH + Co KG

All rights reserved

## Contact

HIMA contact details:

HIMA Paul Hildebrandt GmbH + Co KG

P.O. Box 1261

68777 Brühl, Germany

Phone: +49 6202 709-0

Fax: +49 6202 709-107

E-mail: [info@hima.com](mailto:info@hima.com)

Revision index	Revisions	Type of change	
		technical	editorial
1.00	Added: Configuration with SILworX	X	X
1.01	Deleted: Chapter <i>Monitoring the Temperature State</i> integrated in the system manual		X
2.00	Revised: Chapters 3.4.1 and 3.4.2.1 Added: F1 DI 16 014, SIL 4 certified according to EN 50126, EN 50128 and EN 50129, Chapter 4.1.3	X	X

## Table of Contents

<b>1</b>	<b>Introduction</b>	<b>5</b>
1.1	Structure and Use of this Manual	5
1.2	Target Audience	6
1.3	Formatting Conventions	7
1.3.1	Safety Notes	7
1.3.2	Operating Tips	8
<b>2</b>	<b>Safety</b>	<b>9</b>
2.1	Intended Use	9
2.1.1	Environmental Requirements	9
2.1.2	ESD Protective Measures	9
2.2	Residual Risk	10
2.3	Safety Precautions	10
2.4	Emergency Information	10
<b>3</b>	<b>Product Description</b>	<b>11</b>
3.1	Safety Function	11
3.1.1	Safety-Related Digital Inputs	11
3.1.1.1	Reaction in the Event of a Fault	12
3.1.2	Line Control	12
3.2	Equipment, Scope of Delivery	13
3.2.1	IP Address and System ID (SRS)	13
3.3	Type Label	14
3.4	Structure	15
3.4.1	LED Indicators	16
3.4.1.1	Operating Voltage LED	16
3.4.1.2	System LEDs	16
3.4.1.3	Communication LEDs	17
3.4.1.4	I/O LEDs	17
3.4.2	Communication	18
3.4.2.1	Connections for Ethernet Communication	18
3.4.2.2	Network Ports Used for Ethernet Communication	18
3.4.3	Pulsed Outputs	19
3.4.4	Reset Key	19
3.5	Product Data	20
3.5.1	Product Data F1 DI 16 011 (-20 °C)	20
3.5.2	Product Data F1 DI 16 014	21
3.6	Certified HIMatrix F1 DI 16 01	21

<b>4</b>	<b>Start-up</b>	<b>22</b>
<b>4.1</b>	<b>Installation and Mounting</b>	<b>22</b>
4.1.1	Connecting the Digital Inputs	22
4.1.1.1	Surges on Digital Inputs	23
4.1.2	Connection of Digital Pulsed Outputs	23
4.1.3	Cable Plugs	24
4.1.4	Mounting the F1 DI 16 01 in Zone 2	25
<b>4.2</b>	<b>Configuration</b>	<b>26</b>
<b>4.3</b>	<b>Configuration with SILworX</b>	<b>26</b>
4.3.1	Parameters and Error Codes for the Inputs and Outputs	26
4.3.2	Digital Inputs F1 DI 16 01	26
4.3.2.1	Tab: <b>Module</b>	27
4.3.2.2	Tab: <b>DI 16: DO Channels</b>	28
4.3.2.3	Tab: <b>DI 16: DI Channels</b>	28
<b>4.4</b>	<b>Configuration with ELOP II Factory</b>	<b>29</b>
4.4.1	Configuring the Inputs and Outputs	29
4.4.2	Signals and Error Codes for the Inputs and Outputs	29
4.4.3	Digital Inputs F1 DI 16 01	30
4.4.4	Pulsed Outputs F1 DI 16 01	31
<b>5</b>	<b>Operation</b>	<b>32</b>
<b>5.1</b>	<b>Handling</b>	<b>32</b>
<b>5.2</b>	<b>Diagnosis</b>	<b>32</b>
<b>6</b>	<b>Maintenance</b>	<b>33</b>
<b>6.1</b>	<b>Faults</b>	<b>33</b>
<b>6.2</b>	<b>Maintenance Measures</b>	<b>33</b>
6.2.1	Loading the Operating System	33
6.2.2	Proof Test	33
<b>7</b>	<b>Decommissioning</b>	<b>34</b>
<b>8</b>	<b>Transport</b>	<b>35</b>
<b>9</b>	<b>Disposal</b>	<b>36</b>
	<b>Appendix</b>	<b>37</b>
	<b>Glossary</b>	<b>37</b>
	<b>Index of Figures</b>	<b>38</b>
	<b>Index of Tables</b>	<b>39</b>
	<b>Index</b>	<b>40</b>

# 1 Introduction

This manual describes the technical characteristics of the device and its use. It provides information on how to install, start up and configure the module.

## 1.1 Structure and Use of this Manual

The content of this manual is part of the hardware description of the HIMatrix programmable electronic system.

This manual is organized in the following main chapters:

- Introduction
- Safety
- Product Description
- Start-up
- Operation
- Maintenance
- Decommissioning
- Transport
- Disposal

HIMatrix remote I/Os are available for the programming tools SILworX and ELOP II Factory. Which programming tool can be used, depends on the processor operating system of the HIMatrix remote I/O, refer to the following table:

Programming tool	Processor operating system
SILworX	CPU OS V7 and higher
ELOP II Factory	CPU OS up to V6.x

Table 1: Programming Tools for HIMatrix Remote I/Os

In the manual, the differences are specified by using:

- Separated chapters
- Tables differentiating among the versions

---

**i** **Projects created with ELOP II Factory cannot be edited with SILworX, and vice versa!**

---



---

**i** Compact controllers and remote I/Os are referred to as *devices*.

---

Additionally, the following documents must be taken into account:

Name	Content	Document number
HIMatrix System Manual Compact Systems	Hardware description of the HIMatrix compact systems	HI 800 141 E
HIMatrix System Manual Modular System F60	Hardware description of the HIMatrix modular system	HI 800 191 E
HIMatrix Safety Manual	Safety functions of the HIMatrix system	HI 800 023 E
HIMatrix Safety Manual for Railway Applications	Safety functions of the HIMatrix system using the HIMatrix in railway applications	HI 800 437 E
SILworX Online Help	Instructions on how to use SILworX	-
ELOP II Factory Online Help	Instructions on how to use ELOP II Factory, Ethernet IP protocol	-
SILworX First Steps	Introduction to SILworX using the HIMax system as an example	HI 801 103 E
ELOP II Factory First Steps	Introduction to ELOP II Factory	HI 800 006 E

Table 2: Additional Relevant Documents

The latest manuals can be downloaded from the HIMA website at [www.hima.com](http://www.hima.com). The revision index on the footer can be used to compare the current version of existing manuals with the Internet edition.

## 1.2 Target Audience

This document addresses system planners, configuration engineers, programmers of automation devices and personnel authorized to implement, operate and maintain the modules and systems. Specialized knowledge of safety-related automation systems is required.

### 1.3 Formatting Conventions

To ensure improved readability and comprehensibility, the following fonts are used in this document:

<b>Bold</b>	To highlight important parts. Names of buttons, menu functions and tabs that can be clicked and used in the programming tool.
<i>Italics</i>	For parameters and system variables
Courier	Literal user inputs
RUN	Operating state are designated by capitals
Chapter 1.2.3	Cross references are hyperlinks even though they are not particularly marked. When the cursor hovers over a hyperlink, it changes its shape. Click the hyperlink to jump to the corresponding position.

Safety notes and operating tips are particularly marked.

#### 1.3.1 Safety Notes

The safety notes are represented as described below. These notes must absolutely be observed to reduce the risk to a minimum. The content is structured as follows:

- Signal word: warning, caution, notice
- Type and source of risk
- Consequences arising from non-observance
- Risk prevention

#### SIGNAL WORD



**Type and source of risk!**  
**Consequences arising from non-observance**  
**Risk prevention**

The signal words have the following meanings:

- Warning indicates hazardous situation which, if not avoided, could result in death or serious injury.
- Caution indicates hazardous situation which, if not avoided, could result in minor or modest injury.
- Notice indicates a hazardous situation which, if not avoided, could result in property damage.

#### NOTE



**Type and source of damage!**  
**Damage prevention**

1.3.2 Operating Tips

Additional information is structured as presented in the following example:

---

**i**

The text corresponding to the additional information is located here.

---

Useful tips and tricks appear as follows:

---

**TIP**

The tip text is located here.

---



## 2 Safety

All safety information, notes and instructions specified in this document must be strictly observed. The product may only be used if all guidelines and safety instructions are adhered to.

This product is operated with SELV or PELV. No imminent risk results from the product itself. The use in Ex-zone is permitted if additional measures are taken.

### 2.1 Intended Use

HIMatrix components are designed for assembling safety-related controller systems.

When using the components in the HIMatrix system, comply with the following general requirements.

#### 2.1.1 Environmental Requirements

Requirement type	Range of values <sup>1)</sup>
Protection class	Protection class III in accordance with IEC/EN 61131-2
Ambient temperature	0...+60 °C
Storage temperature	-40...+85 °C
Pollution	Pollution degree II in accordance with IEC/EN 61131-2
Altitude	< 2000 m
Housing	Standard: IP20
Supply voltage	24 VDC
<sup>1)</sup> The values specified in the technical data apply and are decisive for devices with extended environmental requirements.	

Table 3: Environmental Requirements

Exposing the HIMatrix system to environmental conditions other than those specified in this manual can cause the HIMatrix system to malfunction.

#### 2.1.2 ESD Protective Measures

Only personnel with knowledge of ESD protective measures may modify or extend the system or replace devices.

#### NOTE



##### Device damage due to electrostatic discharge!

- When performing the work, make sure that the workspace is free of static, and wear an ESD wrist strap.
- If not used, ensure that the device is protected from electrostatic discharge, e.g., by storing it in its packaging.

## 2.2 Residual Risk

No imminent risk results from a HIMatrix system itself.

Residual risk may result from:

- Faults related to engineering
- Faults related to the user program
- Faults related to the wiring

## 2.3 Safety Precautions

Observe all local safety requirements and use the protective equipment required on site.

## 2.4 Emergency Information

A HIMatrix system is a part of the safety equipment of a site. If a device or a module fails, the system enters the safe state.

In case of emergency, no action that may prevent the HIMatrix systems from operating safely is permitted.

### 3 Product Description

The safety-related **F1 DI 16 01** remote I/O is a compact system in a metal housing with 16 digital inputs and 4 pulsed outputs.

The remote I/O is available in various model variants for SILworX and ELOP II Factory, see Table 4.

Remote I/Os are connected to individual HIMax or HIMatrix controllers via **safeethernet**. They are used to extend the I/O level, but are not able to run any user program by themselves.

The remote I/O is suitable for mounting in Ex-zone 2, see Chapter 4.1.4.

The device is TÜV-certified for safety-related applications up to SIL 3 (IEC 61508, IEC 61511 and IEC 62061), Cat. 4 and PL e (EN ISO 13849-1) and SIL 4 (EN 50126, EN 50128 and EN 50129).

Further safety standards, application standards and test standards are specified in the certificates available on the HIMA website.

#### 3.1 Safety Function

The remote I/O is equipped with safety-related inputs. The input values on the inputs are safely transmitted to the connected controller via **safeethernet**.

##### 3.1.1 Safety-Related Digital Inputs

The remote I/O is equipped with 16 digital inputs. The state (HIGH, LOW) of each input is signaled by an individual LED.

Mechanical contacts without own power supply or signal power source can be connected to the inputs. Potential-free mechanical contacts without own power supply are fed via an internal short-circuit-proof 24 V power source (LS+). Each 24 V power source supplies a group of 4 mechanical contacts. Figure 1 shows how the connection is performed.

With signal voltage sources, the corresponding ground must be connected to the input (L-), see Figure 1.

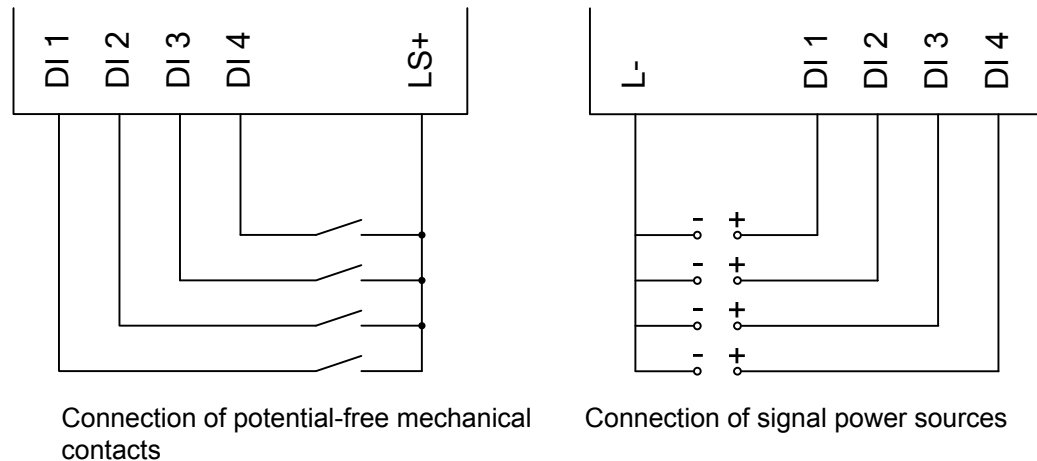

Figure 1: Connections to Safety-Related Digital Inputs

For the external wiring and the connection of sensors, apply the de-energized-to-trip principle. Thus, if a fault occurs, the input signals adopt a de-energized, safe state (low level).

An external wire is not monitored, however, an open-circuit is considered as safe low level.

### 3.1.1.1 Reaction in the Event of a Fault

If the device detects a fault on a digital input, the user program processes a low level in accordance with the de-energized to trip principle.

The device activates the *FAULT* LED.

In addition to the channel signal value, the user program must also consider the corresponding error code.

The error code allows the user to configure additional fault reactions in the user program.

### 3.1.2 Line Control

Line control is used to detect short-circuits or open-circuits and can be configured for the remote I/O, e.g., on EMERGENCY STOP inputs complying with Cat. 4 and PL e in accordance with EN ISO 13849-1.

To this end, connect the pulsed outputs TO 1...TO 2 of the system to the digital inputs (DI) of the same system as follows:

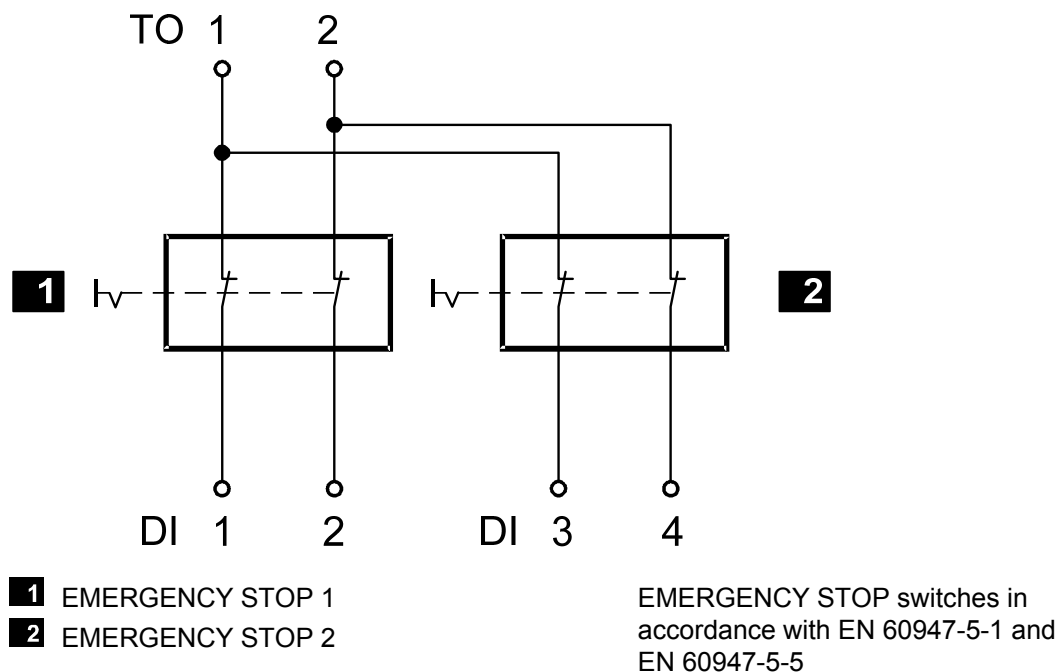

Figure 2: Line Control

The remote I/O pulses the pulsed outputs (TO) to detect short-circuits and open-circuits on the lines connected to the digital inputs (DI). To do so, configure the *Value [BOOL]* -> system variable in SILworX or the *DO[0x].Value* system signal in ELOP II Factory. The variables for the pulsed outputs must begin with channel 1 and reside in direct sequence, one after the other.

If the following faults occur, the *FAULT* LED located on the front plate of the controller blinks, the inputs are set to low level and an (evaluable) error code is created:

- Cross-circuit between two parallel wires.
- Invalid connections of two lines (e.g., TO 2 to DI 3),
- Earth fault on one wire (with earthed ground only).
- Open-circuit or open contacts, i.e., including when one of the two EMERGENCY STOP switches mentioned above has been engaged, the *FAULT* LED blinks and the error code is created.

### 3.2 Equipment, Scope of Delivery

The following table specifies the available remote I/O variants:

Designation	Description
F1 DI 16 01	Remote I/O (16 digital inputs), Operating temperature: 0...+60 °C, for ELOP II Factory programming tool
F1 DI 16 011 (-20 °C)	Remote I/O (16 digital inputs), Operating temperature: -20...+60 °C, for ELOP II Factory programming tool
F1 DI 16 01 SILworX	Remote I/O (16 digital inputs), Operating temperature: 0...+60 °C, for SILworX programming tool
F1 DI 16 011 SILworX (-20 °C)	Remote I/O (16 digital inputs), Operating temperature: -20...+60 °C, for SILworX programming tool
F1 DI 16 014 SILworX	Remote I/O (16 digital inputs), Operating temperature: -25...+70 °C (temperature class T1), Vibration and shock tested according to EN 50125-3 and EN 50155, class 1B according to IEC 61373, for SILworX programming tool

Table 4: Available Variants

#### 3.2.1 IP Address and System ID (SRS)

A transparent label is delivered with the device to allow one to note the IP address and the system ID (SRS for system rack slot) after a change.

IP \_\_\_\_ . \_\_\_\_ . \_\_\_\_ . \_\_\_\_ SRS \_\_\_\_ . \_\_\_\_ . \_\_\_\_

Default value for IP address: 192.168.0.99  
 Default value for SRS: 60 000.200.0 (SILworX)  
 60 000.0.0 (ELOP II Factory)

The label must be affixed such that the ventilation slots in the housing are not obstructed.  
 Refer to the First Steps manual of the programming tool for more information on how to modify the IP address and the system ID.

### 3.3 Type Label

The type plate contains the following details:

- Product name
- Bar code (1D or 2D code)
- Part no.
- Production year
- Hardware revision index (HW Rev.)
- Firmware revision index (FW Rev.)
- Operating voltage
- Mark of conformity

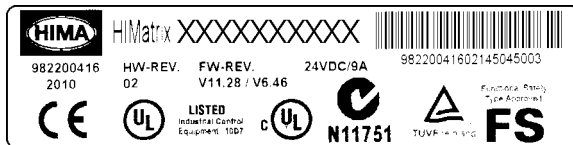

Figure 3: Sample Type Label

### 3.4 Structure

This chapter describes the layout and function of the remote I/Os, and their communication via safeethernet.

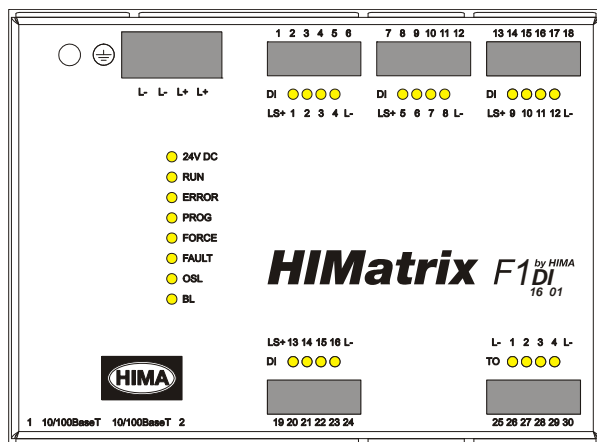

Figure 4: Front View

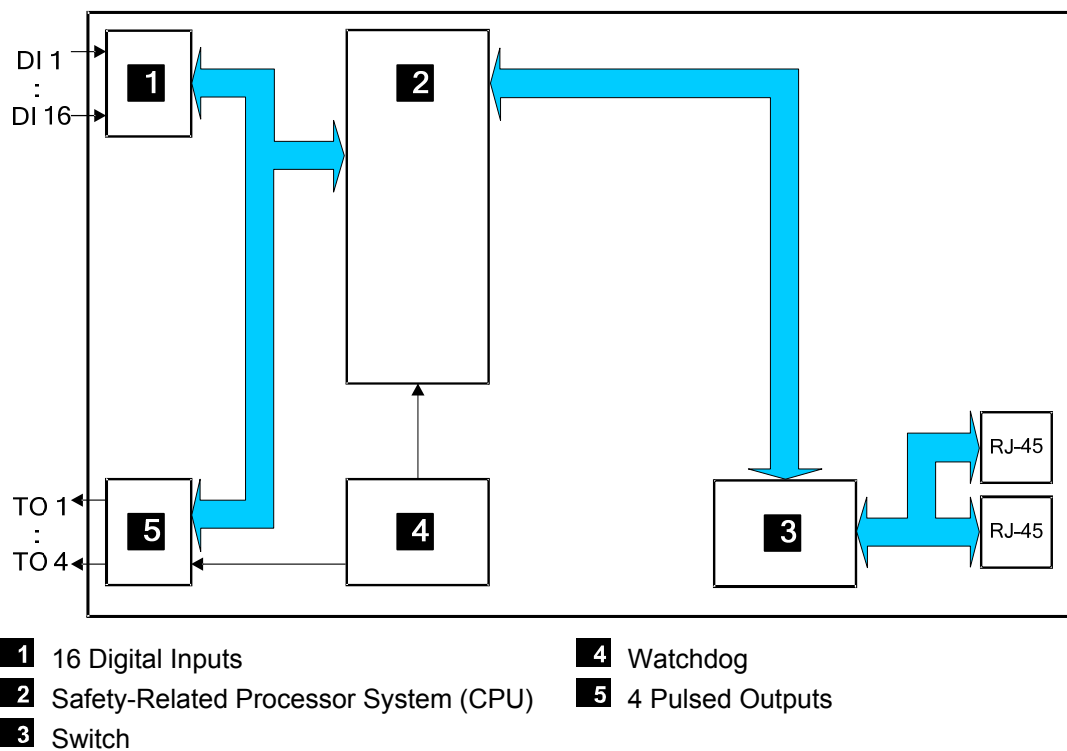

Figure 5: Block Diagram

### 3.4.1 LED Indicators

The light-emitting diodes (LEDs) indicate the operating state of the remote I/O. The LEDs are classified as follows:

- Operating voltage LED
- System LEDs
- Communication LEDs
- I/O LEDs

#### 3.4.1.1 Operating Voltage LED

LED	Color	Status	Description
24 VDC	Green	On	24 VDC operating voltage present
		Off	No operating voltage

Table 5: Operating Voltage LED

#### 3.4.1.2 System LEDs

While the system is being booted, all LEDs are lit simultaneously.

LED	Color	Status	Description
RUN	Green	On	Device in RUN, normal operation
		Blinking	Device in STOP A new operating system is being loaded.
		Off	The device is not in the RUN state.
ERROR	Red	On	The device is in the ERROR STOP state. Internal fault detected by self-tests, e.g., hardware faults or cycle time overrun. The processor system can only be restarted with a command from the PADT (reboot).
		Blinking	If ERROR blinks and all others LEDs are lit simultaneously, the boot loader has detected an operating system fault in the flash memory and waits for a new operating system to be loaded.
		Off	No faults detected.
PROG	Yellow	On	A new configuration is being loaded into the device.
		Blinking	The device switches from INIT to STOP A new operating system is being loaded into the flash ROM.
		Off	No configuration or operating system is being loaded.
FORCE	Yellow	Off	The FORCE LED of a remote I/O is not functioning. The FORCE LED of the associated controller serves to signal the forcing of a remote I/O.
FAULT	Yellow	On	The loaded configuration is not valid. The new operating system is corrupted (after OS download).
		Blinking	Fault while loading a new operating system. One or multiple I/O faults occurred.
		Off	None of the described faults occurred.
OSL	Yellow	Blinking	Operating system emergency loader active.
		Off	Operating system emergency loader inactive.
BL	Yellow	Blinking	OS and OSL binary defective or hardware fault, INIT_FAIL.
		Off	None of the described faults occurred.

Table 6: System LEDs



3.4.1.3 Communication LEDs

All RJ-45 connectors are provided with a small green and a yellow LEDs. The LEDs signal the following states:

LED	Status	Description
Green	On	Full duplex operation
	Blinking	Collision
	Off	Half duplex operation, no collision
Yellow	On	Connection available
	Blinking	Interface activity
	Off	No connection available

Table 7: Ethernet Indicators

3.4.1.4 I/O LEDs

LED	Color	Status	Description
DI 1...16	Yellow	On	The related channel is active (energized).
		Off	The related channel is inactive (de-energized).
TO 1...4	Yellow	On	Pulsed output activated.
		Off	Pulsed output deactivated.

Table 8: I/O LEDs

### 3.4.2 Communication

The remote I/O communicates with the associated controller via **safeethernet**.

#### 3.4.2.1 Connections for Ethernet Communication

Property	Description
Port	2 x RJ-45
Transfer standard	10BASE-T/100BASE-Tx, half and full duplex
Auto negotiation	Yes
Auto crossover	Yes
IP address	Freely configurable <sup>1)</sup>
Subnet mask	Freely configurable <sup>1)</sup>
Supported protocols	<ul style="list-style-type: none"> <li>▪ Safety-related: <b>safeethernet</b></li> <li>▪ Standard protocols: Programming and debugging tool (PADT), SNTP</li> </ul>
<sup>1)</sup> The general rules for assigning IP address and subnet masks must be adhered to.	

Table 9 Ethernet Interfaces Properties

The two RJ-45 connectors with integrated LEDs are located on the bottom left-hand side of the housing. For more information on the communication LEDs, refer to Chapter 3.4.1.3.

The connection parameters are read based on the MAC address (media access control address) defined during manufacturing.

The MAC address for the remote I/O is specified on a label located above the two RJ-45 connectors (1 and 2).

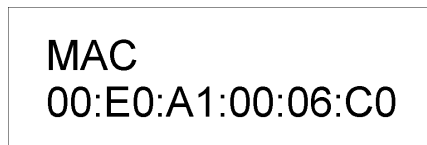

Figure 6: Sample MAC Address Label

The remote I/O is equipped with an integrated switch for Ethernet communication. For further information on the integrated switch and **safeethernet**, refer to Chapter *Communication* of the system manual for compact systems (HI 800 141 E).

#### 3.4.2.2 Network Ports Used for Ethernet Communication

UDP ports	Use
8000	Programming and operation with the programming tools
8001	Configuration of the remote I/O using the PES (ELOP II Factory)
8004	Configuration of the remote I/O using the PES (SILworX)
6010	<b>safeethernet</b>
123	SNTP (time synchronization between PES and remote I/O, PES and external devices)

Table 10: Network Ports in Use

### 3.4.3 Pulsed Outputs

The digital pulsed outputs can be used to detect short-circuits and open-circuits on digital inputs, e.g., on EMERGENCY STOP button complying with Cat. 4 and PL e in accordance with EN ISO 13849-1.

---

**i**

Pulsed outputs must not be used as safety-related outputs (e.g., for activating safety-related actuators)!

---

### 3.4.4 Reset Key

The remote I/O is equipped with a reset key. The key is only required if the user name or password for administrator access is not known. If only the IP address set for the remote I/O does not match the PADT (PC), the connection can be established with a `Route add` entry on the PC.

---

**i**

Only the model variants without protective lacquer are equipped with a reset key.

---

The key can be accessed through a small round hole located approximately 5 cm from the upper left-hand side of the housing. The key is engaged using a suitable pin made of insulating material to avoid short-circuits within the remote I/O.

The reset is only effective if the remote I/O is rebooted (switched off and on) while the key is simultaneously engaged for at least 20 s. Engaging the key during operation has no effect.

Properties and behavior of the remote I/O after a reboot with engaged reset key:

- Connection parameters (IP address and system ID) are set to the default values.
- All accounts are deactivated except for the *administrator* default account with empty password.

After a new reboot without the reset key engaged, the connection parameters (IP address and system ID) and accounts become effective.

- Those configured by the user.
- Those valid prior to rebooting with the reset key engaged, if no changes were performed.

### 3.5 Product Data

General	
Response time	≥ 20 ms
Ethernet interfaces	2 x RJ-45, 10BASE-T/100BASE-Tx with integrated switch
Operating voltage	24 VDC, -15...+20 %, $r_{PP} \leq 15\%$ , from a power supply unit with safe insulation in accordance with IEC 61131-2
Current input	max. 0.8 A
Fuse (external)	10 A time-lag (T)
Operating temperature	0...+60 °C
Storage temperature	-40...+85 °C
Type of protection	IP20
Max. dimensions (without plug)	Width: 152 mm (with housing screws) Height: 114 mm (with fixing bolt) Depth: 66 mm (with earthing screw)
Weight	0.7 kg

Table 11: Product Data

Digital inputs	
Number of inputs	16 (non-galvanically separated)
High level: voltage current input	15...30 VDC ≥ 2 mA at 15 V
Low level: voltage current input	max. 5 VDC max. 1.5 mA (1 mA at 5 V)
Switching point	typ. 7.5 V
Switching time	250 μs
Supply	4 x 19.2 V / 40 mA (at 24 V), short-circuit-proof

Table 12: Specifications for Digital Inputs

Pulsed outputs	
Number of outputs	4 (non-galvanically separated)
Output voltage	≥ L+ minus 4 V
Output current	approx. 60 mA
Minimum load	none
Behavior upon overload	4 x ≥ 19.2 V, short-circuit current 60 mA at 24 V

Table 13: Specifications for the Pulsed Outputs

#### 3.5.1 Product Data F1 DI 16 011 (-20 °C)

The F1 DI 16 011 (-20 °C) model variant is intended for use at the extended temperature range of -20...+60 °C. The electronic components are coated with a protective lacquer.

F1 DI 16 011	
Operating temperature	-20...+60 °C
Weight	approx. 0.7 kg

Table 14: Product Data F1 DI 16 011 (-20 °C)

3.5.2 Product Data F1 DI 16 014

The F1 DI 16 014 model variant is intended for use in railway applications. The electronic components are coated with a protective lacquer.

F1 DI 16 014	
Operating temperature	-25...+70 °C
Weight	approx. 0.7 kg

Table 15: Product Data F1 DI 16 014

The remote I/O F1 DI 16 014 meets the conditions for vibrations and shock test according to IEC 61373, category 1, class B.

3.6 Certified HIMatrix F1 DI 16 01

HIMatrix F1 DI 16 01	
CE	EMC, ATEX Zone 2
TÜV	IEC 61508 1-7:2000 up to SIL 3 IEC 61511:2004 EN ISO 13849-1:2008 up to Cat. 4 und PL e
UL Underwriters Laboratories Inc.	ANSI/UL 508, NFPA 70 – Industrial Control Equipment CSA C22.2 No.142 UL 1998 Software Programmable Components NFPA 79 Electrical Standard for Industrial Machinery IEC 61508
FM Approvals	Class I, DIV 2, Groups A, B, C and D Class 3600, 1998 Class 3611, 1999 Class 3810, 1989 Including Supplement #1, 1995 CSA C22.2 No. 142 CSA C22.2 No. 213
TÜV CENELEC	Railway application EN 50126: 1999 up to SIL 4 EN 50128: 2001 up to SIL 4 EN 50129: 2003 up to SIL 4

Table 16: Certificates

## 4 Start-up

To start up the remote I/O, it must be mounted, connected and configured in the programming tool.

### 4.1 Installation and Mounting

The remote I/O is mounted on a 35 mm DIN rail such as described in the HIMatrix system manual for compact systems.

When laying cables (long cables, in particular), take appropriate measures to avoid interference, e.g., by separating the signal lines from the power lines.

When dimensioning the cables, ensure that their electrical properties have no negative impact on the measuring circuit.

#### 4.1.1 Connecting the Digital Inputs

Use the following terminals to connect the digital inputs:

Terminal	Designation	Function (inputs DI)
1	LS+	Sensor supply of the inputs 1...4
2	1	Digital input 1
3	2	Digital input 2
4	3	Digital input 3
5	4	Digital input 4
6	L-	Ground
Terminal	Designation	Function (inputs DI)
7	LS+	Sensor supply of the inputs 5...8
8	5	Digital input 5
9	6	Digital input 6
10	7	Digital input 7
11	8	Digital input 8
12	L-	Ground
Terminal	Designation	Function (inputs DI)
13	LS+	Sensor supply of the inputs 9...12
14	9	Digital input 9
15	10	Digital input 10
16	11	Digital input 11
17	12	Digital input 12
18	L-	Ground
Terminal	Designation	Function (inputs DI)
19	LS+	Sensor supply of the inputs 13...16
20	13	Digital input 13
21	14	Digital input 14
22	15	Digital input 15
23	16	Digital input 16
24	L-	Ground

Table 17: Terminal Assignment for the Digital Inputs

4.1.1.1 Surges on Digital Inputs

Due to the short cycle time of the HIMatrix systems, a surge pulse as described in EN 61000-4-5 can be read in to the digital inputs as a short-term high level.

The following measures ensure proper operation in environments where surges may occur:

1. Install shielded input wires
2. Program noise blanking in the user program. A signal must be present for at least two cycles before it is evaluated. The fault reaction is triggered with a corresponding delay.

**i**

The measures specified above are not necessary if the plant design precludes surges from occurring within the system.

In particular, the design must include protective measures with respect to overvoltage, lightning, earth grounding and plant wiring in accordance with the relevant standards and the instructions specified in the system manual (HI 800 141 E or HI 800 191 E).

4.1.2 Connection of Digital Pulsed Outputs

Use the following terminals to connect the 4 digital pulsed outputs:

Terminal	Designation	Function (pulsed outputs TO)
25	L-	Ground
26	1	Pulsed output 1
27	2	Pulsed output 2
28	3	Pulsed output 3
29	4	Pulsed output 4
30	L-	Ground

Table 18: Terminal Assignment for the Digital Pulsed Outputs

### 4.1.3 Cable Plugs

Cable plugs attached to the pin headers of the devices are used to connect to the power supply and to the field zone. The cable plugs are included within the scope of delivery of the HIMatrix devices and modules.

The devices power supply connections feature the following properties:

Connection to the power supply	
Cable plugs	Four poles, screw terminals
Wire cross-section	0.2...2.5 mm <sup>2</sup> (single-wire) 0.2...2.5 mm <sup>2</sup> (finely stranded) 0.2...2.5 mm <sup>2</sup> (with wire end ferrule)
Stripping length	10 mm
Screwdriver	Slotted 0.6 x 3.5 mm
Tightening torque	0.4...0.5 Nm

Table 19: Power Supply Cable Plug Properties

Connection to the field zone	
Number of cable plugs	5 pieces, six poles, screw terminals
Wire cross-section	0.2...1.5 mm <sup>2</sup> (single-wire) 0.2...1.5 mm <sup>2</sup> (finely stranded) 0.2...1.5 mm <sup>2</sup> (with wire end ferrule)
Stripping length	6 mm
Screwdriver	Slotted 0.4 x 2.5 mm
Tightening torque	0.2...0.25 Nm

Table 20: Input and Output Cable Plug Properties



### 4.1.4 Mounting the F1 DI 16 01 in Zone 2

(EC Directive 94/9/EC, ATEX)

The remote I/O is suitable for mounting in zone 2. Refer to the corresponding declaration of conformity available on the HIMA website.

When mounting the device, observe the special conditions specified in the following section.

#### Specific Conditions X

1. Mount the remote I/O in an enclosure that meets the EN 60079-15 requirements and achieves a type of protection of at least IP54, in accordance with EN 60529. Provide the device with the following label:

**Work is only permitted in the de-energized state**

Exception:

If a potentially explosive atmosphere has been precluded, work can be also performed when the device is under voltage.

2. The enclosure in use must be able to safely dissipate the generated heat. Depending on the output load and supply voltage, the HIMatrix F1 DI 16 01 has a power dissipation ranging between 7 W and 17 W.
3. Protect the HIMatrix F1 DI 16 01 with a 10 A time-lag fuse.  
The 24 VDC power must come from a power supply unit with safe isolation. Use power supply units of type PELV or SELV only.
4. Applicable standards:  

VDE 0170/0171 Part 16,	DIN EN 60079-15: 2004-5
VDE 0165 Part 1,	DIN EN 60079-14: 1998-08

Pay particular attention to the following sections

DIN EN 60079-15:

Chapter 5	Design
Chapter 6	Terminals and cabling
Chapter 7	Air and creeping distances
Chapter 14	Connectors

DIN EN 60079-14:

Chapter 5.2.3	Equipment for use in zone 2
Chapter 9.3	Cabling for zones 1 and 2
Chapter 12.2	Equipment for zones 1 and 2

The remote I/O is additionally equipped with the label represented below:

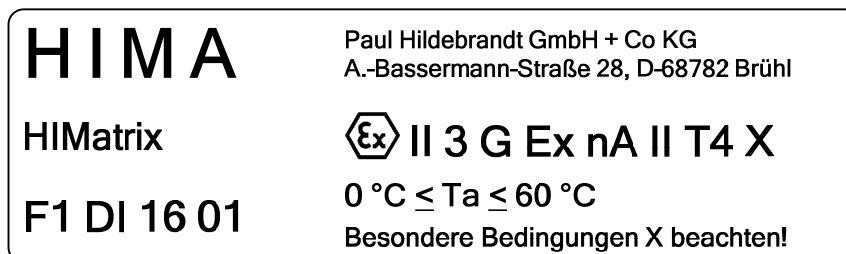

Figure 7: Label for Ex Conditions

## 4.2 Configuration

The remote I/O can be configured using a programming tool, SILworX or ELOP II Factory. Which programming tool should be used, depends on the revision status of the operating system (firmware):

- SILworX is required for CPU OS V7 and higher.
- ELOP II Factory is required for CPU OS up to V6.x.

---

### i

How to switch between operating systems is described in Chapter *Loading Operating Systems* of the system manual for compact systems (HI 800 141 E).

---

## 4.3 Configuration with SILworX

In the Hardware Editor, the remote I/Os are represented like a base plate equipped with the following modules:

- Processor module (CPU)
- Input module (DI 16) with line control

Double-click the module to open the Detail View with the corresponding tabs. The tabs are used to assign the global variables configured in the user program to the system parameter of the corresponding module.

### 4.3.1 Parameters and Error Codes for the Inputs and Outputs

The following tables specify the system parameters that can be read and set for the inputs and outputs, including the corresponding error codes.

In the user program, the error codes can be read using the variables assigned within the logic.

The error codes can also be displayed in SILworX.

### 4.3.2 Digital Inputs F1 DI 16 01

The following tables present the statuses and parameters for the input module (DI 16) in the same order as given in the Hardware Editor.

4.3.2.1 Tab **Module**

The **Module** tab contains the following system parameters:

System parameter	Data type	R/W	Description	
DI Number of Pulsed Channels	USINT	W	Number of pulsed outputs (supply outputs)	
			<b>Coding</b>	<b>Description</b>
			0	No pulsed output planned for SC/OC <sup>1)</sup> detection
			1	Pulsed output 1 planned for SC/OC <sup>1)</sup> detection
			2	Pulsed output 1 and 2 planned for SC/OC <sup>1)</sup> detection
4	Pulsed outputs 1...4 planned for SC/OC <sup>1)</sup> detection			
<b>Pulsed outputs must not be used as safety-related outputs!</b>				
DI Pulse Slot	UDINT	W	Pulse module slot (SC/OC <sup>1)</sup> detection), set the value to 3	
DI Pulse Delay [µs]	UINT	W	Waiting time for line control (detection of short-circuits or cross-circuits)	
DI.Error Code	WORD	R	Error codes for all digital inputs	
			<b>Coding</b>	<b>Description</b>
			0x0001	Fault within the digital inputs
0x0002	FTT test of test pattern faulty			
DO.Error Code	WORD	R	Error code of the TO unit as a whole	
			<b>Coding</b>	<b>Description</b>
0x0001	Error of the TO unit as a whole:			
Module Error Code	WORD	R	Module error code	
			<b>Coding</b>	<b>Description</b>
			0x0000	I/O processing, if required with errors see other error codes
			0x0001	No I/O processing (remote I/O not in RUN)
			0x0002	No I/O processing during the booting test
			0x0004	Manufacturer interface operating
			0x0010	No I/O processing: invalid configuration
			0x0020	No I/O processing: fault rate exceeded
0x0040/ 0x0080	No I/O processing: configured module not plugged in			
Module SRS	[UDINT]	R	Slot number (System Rack Slot)	
Module Type	[UINT]	R	Type of the module, target value: 0x002D [45 <sub>dec</sub> ]	

<sup>1)</sup> SC/OC (SC = short-circuit, OC = open-circuit)

Table 21: SILworX - System Parameters for Digital Inputs, **Module** Tab

4.3.2.2 Tab **DI 16: DO Channels**

The **DI 16: Channels** tab contains the following system parameters:

System parameter	Data type	R/W	Description				
Channel no.	---	R	Channel number, defined by default				
-> Error Code [BYTE]	BYTE	R	Error code of the individual digital pulsed output channels: <table border="1"> <thead> <tr> <th>Coding</th> <th>Description</th> </tr> </thead> <tbody> <tr> <td>0x01</td> <td>Fault in the digital output module</td> </tr> </tbody> </table>	Coding	Description	0x01	Fault in the digital output module
Coding	Description						
0x01	Fault in the digital output module						
Value [BOOL] ->	BOOL	W	Output value for DO channels: 1 = output energized 0 = output de-energized <b>Pulsed outputs must not be used as safety-related outputs!</b>				

Table 22: SILworX - System Parameters for Pulsed Outputs, **DI 16: DO Channels** Tab4.3.2.3 Tab **DI 16: DI Channels**

The **DI 16: Channels** tab contains the following system parameters.

System parameter	Data type	R/W	Description												
Channel no.	---	R	Channel number, defined by default												
-> Error Code [BYTE]	BYTE	R	Error codes for the digital input channels <table border="1"> <thead> <tr> <th>Coding</th> <th>Description</th> </tr> </thead> <tbody> <tr> <td>0x01</td> <td>Fault in the analog input module</td> </tr> <tr> <td>0x10</td> <td>Short-circuit of the channel</td> </tr> <tr> <td>0x80</td> <td>Intermittence between pulsed output TO and digital input DI, e.g., <ul style="list-style-type: none"> <li>▪ Open-circuit</li> <li>▪ Open switch</li> <li>▪ L+ undervoltage</li> </ul> </td> </tr> </tbody> </table>	Coding	Description	0x01	Fault in the analog input module	0x10	Short-circuit of the channel	0x80	Intermittence between pulsed output TO and digital input DI, e.g., <ul style="list-style-type: none"> <li>▪ Open-circuit</li> <li>▪ Open switch</li> <li>▪ L+ undervoltage</li> </ul>				
Coding	Description														
0x01	Fault in the analog input module														
0x10	Short-circuit of the channel														
0x80	Intermittence between pulsed output TO and digital input DI, e.g., <ul style="list-style-type: none"> <li>▪ Open-circuit</li> <li>▪ Open switch</li> <li>▪ L+ undervoltage</li> </ul>														
-> Value [BOOL]	BOOL	R	Input values for the digital input channels 0 = input de-energized 1 = input energized												
Pulsed Channels [USINT] ->	USINT	W	Source channel for pulsed supply <table border="1"> <thead> <tr> <th>Coding</th> <th>Description</th> </tr> </thead> <tbody> <tr> <td>0</td> <td>Input channel</td> </tr> <tr> <td>1</td> <td>Pulse of the 1st TO channel</td> </tr> <tr> <td>2</td> <td>Pulse of the 2nd TO channel</td> </tr> <tr> <td>3</td> <td>Pulse of the 3rd TO channel</td> </tr> <tr> <td>4</td> <td>Pulse of the 4th TO channel</td> </tr> </tbody> </table>	Coding	Description	0	Input channel	1	Pulse of the 1st TO channel	2	Pulse of the 2nd TO channel	3	Pulse of the 3rd TO channel	4	Pulse of the 4th TO channel
Coding	Description														
0	Input channel														
1	Pulse of the 1st TO channel														
2	Pulse of the 2nd TO channel														
3	Pulse of the 3rd TO channel														
4	Pulse of the 4th TO channel														

Table 23: SILworX - System Parameters for Digital Inputs, **DI 16: DI Channels** Tab

## 4.4 Configuration with ELOP II Factory

### 4.4.1 Configuring the Inputs and Outputs

The signals previously defined in the Signal Editor (Hardware Management) are assigned to the individual channels (inputs) using ELOP II Factory. Refer to the system manual for compact systems or the online help for more details.

The following chapter describes the system signals used for assigning signals in the remote I/O.

### 4.4.2 Signals and Error Codes for the Inputs and Outputs

The following tables specify the system signals that can be read and set for the inputs and outputs, including the corresponding error codes.

In the user program, the error codes can be read using the signals assigned within the logic.

The error codes can also be displayed in ELOP II Factory.

4.4.3 Digital Inputs F1 DI 16 01

System signal	R/W	Description																
Mod.SRS [UDINT]	R	Slot number (System Rack Slot)																
Mod. Type [UINT]	R	Type of the module, target value: 0x002D [45 <sub>dec</sub> ]																
Mod. Error Code [WORD]	R	Module error code																
		<table border="1"> <thead> <tr> <th>Coding</th> <th>Description</th> </tr> </thead> <tbody> <tr> <td>0x0000</td> <td>I/O processing, if required with errors see other error codes</td> </tr> <tr> <td>0x0001</td> <td>No I/O processing (remote I/O not in RUN)</td> </tr> <tr> <td>0x0002</td> <td>No I/O processing during the booting test</td> </tr> <tr> <td>0x0004</td> <td>Manufacturer interface operating</td> </tr> <tr> <td>0x0010</td> <td>No I/O processing: invalid configuration</td> </tr> <tr> <td>0x0020</td> <td>No I/O processing: fault rate exceeded</td> </tr> <tr> <td>0x0040/ 0x0080</td> <td>No I/O processing: configured module not plugged in</td> </tr> </tbody> </table>	Coding	Description	0x0000	I/O processing, if required with errors see other error codes	0x0001	No I/O processing (remote I/O not in RUN)	0x0002	No I/O processing during the booting test	0x0004	Manufacturer interface operating	0x0010	No I/O processing: invalid configuration	0x0020	No I/O processing: fault rate exceeded	0x0040/ 0x0080	No I/O processing: configured module not plugged in
		Coding	Description															
		0x0000	I/O processing, if required with errors see other error codes															
		0x0001	No I/O processing (remote I/O not in RUN)															
		0x0002	No I/O processing during the booting test															
		0x0004	Manufacturer interface operating															
		0x0010	No I/O processing: invalid configuration															
		0x0020	No I/O processing: fault rate exceeded															
0x0040/ 0x0080	No I/O processing: configured module not plugged in																	
DI.Error Code [WORD]	R	Error codes for all digital inputs																
DI[xx].Error Code [BYTE]	R	Error codes for the digital input channels																
		<table border="1"> <thead> <tr> <th>Coding</th> <th>Description</th> </tr> </thead> <tbody> <tr> <td>0x01</td> <td>Fault within the digital inputs</td> </tr> <tr> <td>0x002</td> <td>FTT test of test pattern faulty</td> </tr> </tbody> </table>	Coding	Description	0x01	Fault within the digital inputs	0x002	FTT test of test pattern faulty										
		Coding	Description															
0x01	Fault within the digital inputs																	
0x002	FTT test of test pattern faulty																	
<table border="1"> <thead> <tr> <th>Coding</th> <th>Description</th> </tr> </thead> <tbody> <tr> <td>0x01</td> <td>Fault in the analog input module</td> </tr> <tr> <td>0x10</td> <td>Short-circuit of the channel</td> </tr> <tr> <td>0x80</td> <td>Intermittence between pulsed output TO and digital input DI, e.g.,                             <ul style="list-style-type: none"> <li>▪ Open-circuit</li> <li>▪ Open switch</li> <li>▪ L+ undervoltage</li> </ul> </td> </tr> </tbody> </table>	Coding	Description	0x01	Fault in the analog input module	0x10	Short-circuit of the channel	0x80	Intermittence between pulsed output TO and digital input DI, e.g., <ul style="list-style-type: none"> <li>▪ Open-circuit</li> <li>▪ Open switch</li> <li>▪ L+ undervoltage</li> </ul>										
Coding	Description																	
0x01	Fault in the analog input module																	
0x10	Short-circuit of the channel																	
0x80	Intermittence between pulsed output TO and digital input DI, e.g., <ul style="list-style-type: none"> <li>▪ Open-circuit</li> <li>▪ Open switch</li> <li>▪ L+ undervoltage</li> </ul>																	
DI[xx].Value [BOOL]	R	Input values for the digital input channels 0 = input de-energized 1 = input energized																
DI Number of Pulsed Channels [USINT]	W	Number of pulsed outputs (supply outputs)																
		<table border="1"> <thead> <tr> <th>Coding</th> <th>Description</th> </tr> </thead> <tbody> <tr> <td>0</td> <td>No pulsed output planned for SC/OC<sup>(1)</sup> detection</td> </tr> <tr> <td>1</td> <td>Pulsed output 1 planned for SC/OC<sup>(1)</sup> detection</td> </tr> <tr> <td>2</td> <td>Pulsed output 1 and 2 planned for SC/OC<sup>(1)</sup> detection</td> </tr> <tr> <td>4</td> <td>Pulsed outputs 1...4 planned for SC/OC<sup>(1)</sup> detection</td> </tr> </tbody> </table>	Coding	Description	0	No pulsed output planned for SC/OC <sup>(1)</sup> detection	1	Pulsed output 1 planned for SC/OC <sup>(1)</sup> detection	2	Pulsed output 1 and 2 planned for SC/OC <sup>(1)</sup> detection	4	Pulsed outputs 1...4 planned for SC/OC <sup>(1)</sup> detection						
		Coding	Description															
		0	No pulsed output planned for SC/OC <sup>(1)</sup> detection															
		1	Pulsed output 1 planned for SC/OC <sup>(1)</sup> detection															
2	Pulsed output 1 and 2 planned for SC/OC <sup>(1)</sup> detection																	
4	Pulsed outputs 1...4 planned for SC/OC <sup>(1)</sup> detection																	
<b>Pulsed outputs must not be used as safety-related outputs!</b>																		
DI Pulse Slot [UDINT]	W	Pulse module slot (SC/OC <sup>(1)</sup> detection), set the value to 1																
DI[xx]. Pulsed Output [USINT]	W	Source channel for pulsed supply																
		<table border="1"> <thead> <tr> <th>Coding</th> <th>Description</th> </tr> </thead> <tbody> <tr> <td>0</td> <td>Input channel</td> </tr> <tr> <td>1</td> <td>Pulse of the 1st TO channel</td> </tr> <tr> <td>2</td> <td>Pulse of the 2nd TO channel</td> </tr> <tr> <td>3</td> <td>Pulse of the 3rd TO channel</td> </tr> <tr> <td>4</td> <td>Pulse of the 4th TO channel</td> </tr> </tbody> </table>	Coding	Description	0	Input channel	1	Pulse of the 1st TO channel	2	Pulse of the 2nd TO channel	3	Pulse of the 3rd TO channel	4	Pulse of the 4th TO channel				
		Coding	Description															
		0	Input channel															
		1	Pulse of the 1st TO channel															
		2	Pulse of the 2nd TO channel															
3	Pulse of the 3rd TO channel																	
4	Pulse of the 4th TO channel																	

System signal	R/W	Description
DI Pulse Delay [10E-6s] [UINT]	W	Waiting time for line control (detection of short-circuits or cross-circuits)
<sup>1)</sup> SC/OC (SC = short-circuit, OC = open-circuit)		

Table 24: ELOP II Factory - Digital Input System Signals

4.4.4 Pulsed Outputs F1 DI 16 01

System signal	R/W	Description																
Mod.SRS [UDINT]	R	Slot number (System Rack Slot)																
Mod. Type [UINT]	R	Type of the module, target value: 0x002D [45 <sub>dec</sub> ]																
Mod. Error Code [WORD]	R	Module error code																
		<table border="1"> <thead> <tr> <th>Coding</th> <th>Description</th> </tr> </thead> <tbody> <tr> <td>0x0000</td> <td>I/O processing, if required with errors see other error codes</td> </tr> <tr> <td>0x0001</td> <td>No I/O processing (remote I/O not in RUN)</td> </tr> <tr> <td>0x0002</td> <td>No I/O processing during the booting test</td> </tr> <tr> <td>0x0004</td> <td>Manufacturer interface operating</td> </tr> <tr> <td>0x0010</td> <td>No I/O processing: invalid configuration</td> </tr> <tr> <td>0x0020</td> <td>No I/O processing: fault rate exceeded</td> </tr> <tr> <td>0x0040/ 0x0080</td> <td>No I/O processing: configured module not plugged in</td> </tr> </tbody> </table>	Coding	Description	0x0000	I/O processing, if required with errors see other error codes	0x0001	No I/O processing (remote I/O not in RUN)	0x0002	No I/O processing during the booting test	0x0004	Manufacturer interface operating	0x0010	No I/O processing: invalid configuration	0x0020	No I/O processing: fault rate exceeded	0x0040/ 0x0080	No I/O processing: configured module not plugged in
		Coding	Description															
		0x0000	I/O processing, if required with errors see other error codes															
		0x0001	No I/O processing (remote I/O not in RUN)															
		0x0002	No I/O processing during the booting test															
		0x0004	Manufacturer interface operating															
		0x0010	No I/O processing: invalid configuration															
0x0020	No I/O processing: fault rate exceeded																	
0x0040/ 0x0080	No I/O processing: configured module not plugged in																	
DO.Error Code [WORD]	R	Error code of the TO unit as a whole																
		<table border="1"> <thead> <tr> <th>Coding</th> <th>Description</th> </tr> </thead> <tbody> <tr> <td>0x0001</td> <td>Error of the TO unit as a whole:</td> </tr> </tbody> </table>	Coding	Description	0x0001	Error of the TO unit as a whole:												
Coding	Description																	
0x0001	Error of the TO unit as a whole:																	
DO[xx].Error Code [BYTE]	R	Error code of the individual digital pulsed output channels:																
		<table border="1"> <thead> <tr> <th>Coding</th> <th>Description</th> </tr> </thead> <tbody> <tr> <td>0x01</td> <td>Fault in the digital output module</td> </tr> </tbody> </table>	Coding	Description	0x01	Fault in the digital output module												
Coding	Description																	
0x01	Fault in the digital output module																	
DO[xx].Value [BOOL]	W	Output value for TO channels: 1 = output energized 0 = output de-energized  <b>Pulsed outputs must not be used as safety-related outputs!</b>																

Table 25: ELOP II Factory - System Signals for the Pulsed Outputs

## 5 Operation

The remote I/O can only be operated together with a controller. No specific monitoring is required for remote I/Os.

### 5.1 Handling

Handling of the remote I/O during operation is not required.

### 5.2 Diagnosis

A first diagnosis results from evaluating the LEDs, see Chapter 3.4.1.

The device diagnostic history can also be read using the programming tool.



## 6 Maintenance

No maintenance measures are required during normal operation.

If a failure occurs, the defective module or device must be replaced with a module or device of the same type or with a replacement model approved by HIMA.

Only the manufacturer is authorized to repair the device/module.

### 6.1 Faults

Refer to Chapter 3.4.1.3, for more information on the fault reaction of digital inputs.

If the test harnesses detect safety-critical faults, the module enters the STOP\_INVALID state and will remain in this state. This means that the input signals are no longer processed by the device and the outputs switch to the de-energized, safe state. The evaluation of diagnostics provides information on the fault cause.

### 6.2 Maintenance Measures

The following measures are required for the device:

- Loading the operating system, if a new version is required
- Executing the proof test

#### 6.2.1 Loading the Operating System

HIMA is continuously improving the operating system of the devices. HIMA recommends to use system downtimes to load a current version of the operating system into the devices.

Refer to the release list to check the consequences of the new operation system version on the system!

The operating system is loaded using the programming tool.

Prior to loading the operating system, the device must be in STOP (displayed in the programming tool). Otherwise, stop the device.

For more information, refer to the programming tool documentation.

#### 6.2.2 Proof Test

HIMatrix devices and modules must be subjected to a proof test in intervals of 10 years. For more information, refer to the safety manual (HI 800 023 E).

## 7 Decommissioning

Remove the supply voltage to decommission the device. Afterwards pull out the pluggable screw terminal connector blocks for inputs and outputs and the Ethernet cables.

## 8 Transport

To avoid mechanical damage, HIMatrix components must be transported in packaging.

Always store HIMatrix components in their original product packaging. This packaging also provides protection against electrostatic discharge. Note that the product packaging alone is not suitable for transport.

## 9 Disposal

Industrial customers are responsible for correctly disposing of decommissioned HIMatrix hardware. Upon request, a disposal agreement can be arranged with HIMA.

All materials must be disposed of in an ecologically sound manner.



## Appendix

### Glossary

Term	Description
ARP	Address resolution protocol: Network protocol for assigning the network addresses to hardware addresses
AI	Analog input
AO	Analog output
COM	Communication module
CRC	Cyclic redundancy check
DI	Digital input
DO	Digital output
ELOP II Factory	Programming tool for HIMatrix systems
EMC	Electromagnetic compatibility
EN	European norm
ESD	Electrostatic discharge
FB	Fieldbus
FBD	Function block diagrams
FTT	Fault tolerance time
ICMP	Internet control message protocol: Network protocol for status or error messages
IEC	International electrotechnical commission
MAC address	Media access control address: Hardware address of one network connection
PADT	Programming and debugging tool (in accordance with IEC 61131-3), PC with SILworX or ELOP II Factory
PE	Protective earth
PELV	Protective extra low voltage
PES	Programmable electronic system
R	Read: The system variable or signal provides value, e.g., to the user program
Rack ID	Base plate identification (number)
Interference-free	Supposing that two input circuits are connected to the same source (e.g., a transmitter). An input circuit is termed <i>interference-free</i> if it does not distort the signals of the other input circuit.
R/W	Read/Write (column title for system variable/signal type)
SELV	Safety extra low voltage
SFF	Safe failure fraction, portion of faults that can be safely controlled
SIL	Safety integrity level (in accordance with IEC 61508)
SILworX	Programming tool for HIMatrix systems
SNTP	Simple network time protocol (RFC 1769)
SRS	System.rack.slot addressing of a module
SW	Software
TMO	Timeout
W	Write: System variable/signal is provided with value, e.g., from the user program
$r_{PP}$	Peak-to-peak value of a total AC component
Watchdog (WD)	Time monitoring for modules or programs. If the watchdog time is exceeded, the module or program enters the ERROR STOP state.
WDT	Watchdog time

**Index of Figures**

<b>Figure 1: Connections to Safety-Related Digital Inputs</b>	<b>11</b>
<b>Figure 2: Line Control</b>	<b>12</b>
<b>Figure 3: Sample Type Label</b>	<b>14</b>
<b>Figure 4: Front View</b>	<b>15</b>
<b>Figure 5: Block Diagram</b>	<b>15</b>
<b>Figure 6: Sample MAC Address Label</b>	<b>18</b>
<b>Figure 7: Label for Ex Conditions</b>	<b>25</b>

**Index of Tables**

<b>Table 1:</b>	<b>Programming Tools for HIMatrix Remote I/Os</b>	<b>5</b>
<b>Table 2:</b>	<b>Additional Relevant Documents</b>	<b>6</b>
<b>Table 3:</b>	<b>Environmental Requirements</b>	<b>9</b>
<b>Table 4:</b>	<b>Available Variants</b>	<b>13</b>
<b>Table 5:</b>	<b>Operating Voltage LED</b>	<b>16</b>
<b>Table 6:</b>	<b>System LEDs</b>	<b>16</b>
<b>Table 7:</b>	<b>Ethernet Indicators</b>	<b>17</b>
<b>Table 8:</b>	<b>I/O LEDs</b>	<b>17</b>
<b>Table 9:</b>	<b>Ethernet Interfaces Properties</b>	<b>18</b>
<b>Table 10:</b>	<b>Network Ports in Use</b>	<b>18</b>
<b>Table 11:</b>	<b>Product Data</b>	<b>20</b>
<b>Table 12:</b>	<b>Specifications for Digital Inputs</b>	<b>20</b>
<b>Table 13:</b>	<b>Specifications for the Pulsed Outputs</b>	<b>20</b>
<b>Table 14:</b>	<b>Product Data F1 DI 16 011 (-20 °C)</b>	<b>20</b>
<b>Table 15:</b>	<b>Product Data F1 DI 16 014</b>	<b>21</b>
<b>Table 16:</b>	<b>Certificates</b>	<b>21</b>
<b>Table 17:</b>	<b>Terminal Assignment for the Digital Inputs</b>	<b>22</b>
<b>Table 18:</b>	<b>Terminal Assignment for the Digital Pulsed Outputs</b>	<b>23</b>
<b>Table 19:</b>	<b>Power Supply Cable Plug Properties</b>	<b>24</b>
<b>Table 20:</b>	<b>Input and Output Cable Plug Properties</b>	<b>24</b>
<b>Table 21:</b>	<b>SILworX - System Parameters for Digital Inputs, Module Tab</b>	<b>27</b>
<b>Table 22:</b>	<b>SILworX - System Parameters for Pulsed Outputs, DI 16: DO Channels Tab</b>	<b>28</b>
<b>Table 23:</b>	<b>SILworX - System Parameters for Digital Inputs, DI 16: DI Channels Tab</b>	<b>28</b>
<b>Table 24:</b>	<b>ELOP II Factory - Digital Input System Signals</b>	<b>31</b>
<b>Table 25:</b>	<b>ELOP II Factory - System Signals for the Pulsed Outputs</b>	<b>31</b>

**Index**

block diagram.....	15	<b>safeethernet</b> .....	18
diagnosis.....	32	safety function .....	11
fault reaction		specifications.....	20
digital inputs .....	12	SRS .....	13
front view.....	15		







SAFETY  
NONSTOP

HIMA Paul Hildebrandt GmbH + Co KG

P.O. Box 1261

68777 Brühl, Germany

Phone: +49 6202 709-0

Fax: +49 6202 709-107

E-mail: [info@hima.com](mailto:info@hima.com) Internet: [www.hima.com](http://www.hima.com)

(1334)